

ozito

PETROL EDGER

25.4 cc 1 HP

INSTRUCTION MANUAL

SPECIFICATIONS

Engine:	25.4cc, 2 Stroke, Air Cooled
Power:	0.75kw (1HP)
Fuel & Oil Mix	40:1
Fuel Tank Capacity:	650ml
Starter Type:	Recoil
Max. No Load Speed:	9000/min
Blade Length:	225mm
Blade Adj. Heights:	-20 to 30mm, 5 position
Tool Weight:	11.5 kgs

ozito.com.au

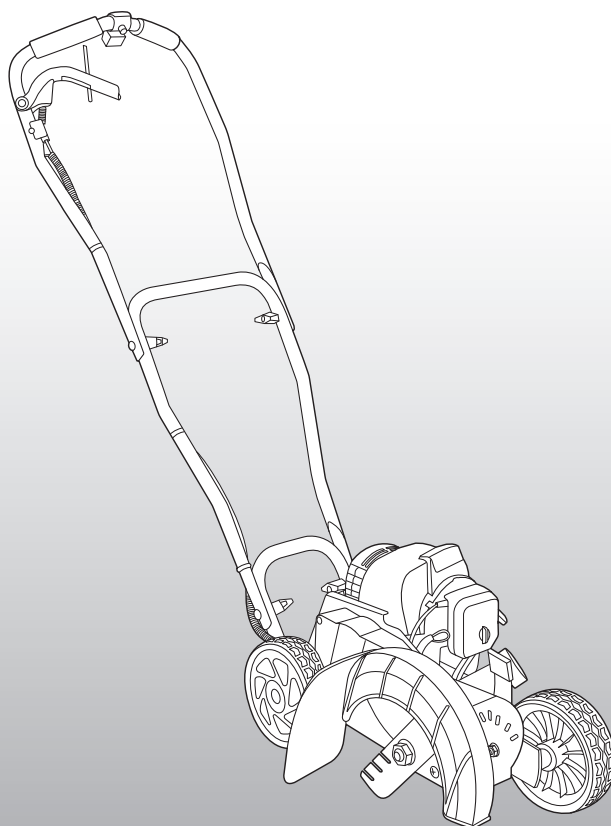

STANDARD EQUIPMENT



Petrol Edger

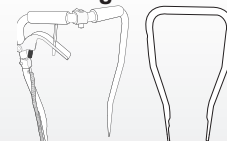

Top & Lower Handle



Fuel Mixing Bottle & Spark Plug Spanner



Spanners, Hex Key & Cable Ties

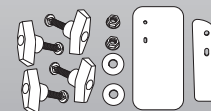

Fasteners, Rubber Mudguard & Plate

1 YEAR REPLACEMENT WARRANTY

PED-3005

WARRANTY

IN ORDER TO MAKE A CLAIM UNDER THIS WARRANTY YOU MUST RETURN THE PRODUCT TO YOUR NEAREST BUNNINGS WAREHOUSE WITH YOUR BUNNINGS REGISTER RECEIPT. PRIOR TO RETURNING YOUR PRODUCT FOR WARRANTY PLEASE TELEPHONE OUR CUSTOMER SERVICE HELPLINE:

Australia 1800 069 486

New Zealand 0508 069 486

TO ENSURE A SPEEDY RESPONSE PLEASE HAVE THE MODEL NUMBER AND DATE OF PURCHASE AVAILABLE. A CUSTOMER SERVICE REPRESENTATIVE WILL TAKE YOUR CALL AND ANSWER ANY QUESTIONS YOU MAY HAVE RELATING TO THE WARRANTY POLICY OR PROCEDURE.

The benefits provided under this warranty are in addition to other rights and remedies which are available to you at law.

Our goods come with guarantees that cannot be excluded at law. You are entitled to a replacement or refund for a major failure and for compensation for any other reasonably foreseeable loss or damage. You are also entitled to have the goods repaired or replaced if the goods fail to be of acceptable quality and the failure does not amount to a major failure.

Generally you will be responsible for all costs associated with a claim under this warranty, however, where you have suffered any additional direct loss as a result of a defective product you may be able to claim such expenses by contacting our customer service helpline above.

1 YEAR REPLACEMENT WARRANTY

Your product is guaranteed for a period of **12 months from the original date of purchase**. If a product is defective it will be replaced in accordance with the terms of this warranty.

Warranty excludes consumable parts, for example: Cutting blade, filters, spark plugs and included accessories.

WARNING

The following actions will result in the warranty being void.

- Professional, Industrial or high frequency use.
- If the tool shows signs of damage or defects caused by or resulting from abuse, accidents or alterations.
- Failure to perform maintenance as set out within the instruction manual.
- If the tool is disassembled or tampered with in any way.

KNOW YOUR PRODUCT

PETROL EDGER

- | | |
|----------------------------------|---------------------|
| 1. Upper handle | 11. Wheel |
| 2. Handle lock knob | 12. Mudguard |
| 3. Lower handle | 13. Priming bulb |
| 4. Engine frame | 14. Cutting blade |
| 5. Spark plug | 15. Choke lever |
| 6. Air filter cover | 16. Blade guard |
| 7. Air filter cover locking knob | 17. Throttle lever |
| 8. Height adjustment lever | 18. Throttle safety |
| 9. Recoil starter | 19. On/Off switch |
| 10. Fuel tank | |

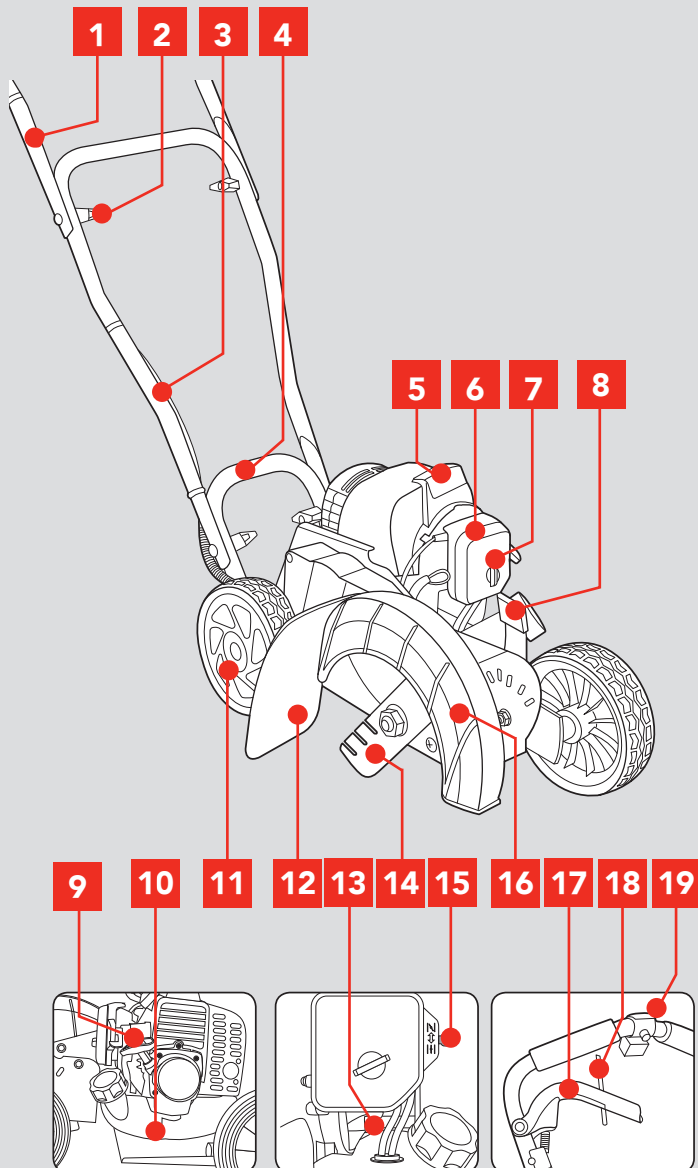

ONLINE MANUAL

Scan this QR Code with your mobile device to take you to the online manual.



SETUP & PREPARATION

1. ASSEMBLY

Securing the Handles

The upper handle and lower handle need to be secured in place before the unit can be used.

1. Place the lower handle frame onto the engine frame. Ensure that the holes in the bars of both frames are in alignment. Using two of the handle lock knob and bolt sets, fix both frames together. The knobs should be positioned on the inside of the frame. Tighten them securely.

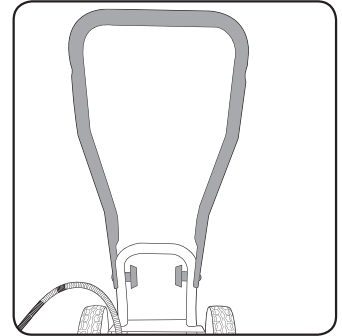

2. Attach the upper handle to the lower handle frame with the remaining two handle lock knobs and bolts.

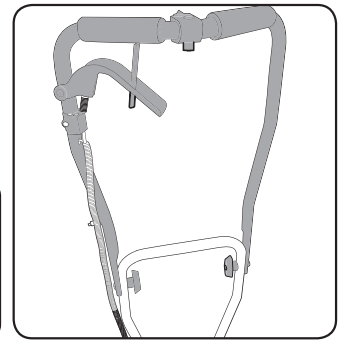
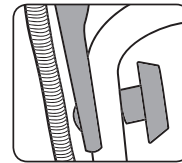

3. Use the cable ties (supplied) to fasten the cable container to the lower handle and upper handle frame.

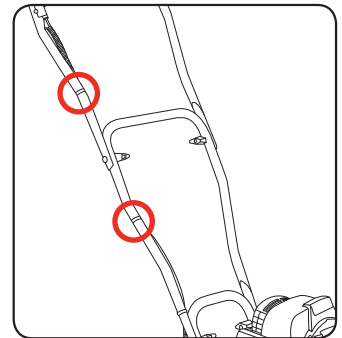

Securing the Mudguard

1. Place the plate over the metal threads on the rear of the blade guard followed by the rubber mudguard.
2. Secure in place with supplied washer and nut.

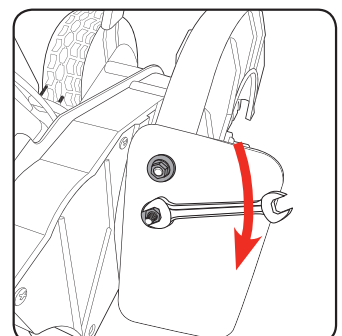
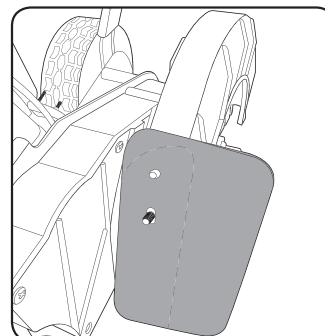

1 YEAR REPLACEMENT WARRANTY

2. FUEL

WARNING! PETROL IS VERY FLAMMABLE. AVOID SMOKING OR CAUSING ANY SPARKS OR FLAMES NEAR FUEL. MAKE SURE THAT YOU STOP THE ENGINE AND ALLOW IT TO COOL BEFORE REFUELLING THE PETROL EDGER. SELECT AN OPEN OUTDOOR AREA FOR FUELLING AND MOVE AT LEAST 3M AWAY FROM THE FUELLING POINT BEFORE STARTING THE ENGINE.

Engine fuel: mix at 40:1 only

NOTE: Only use oil that is expressly labelled for use with air-cooled 2-stroke engines.

NOTE: Always transport and store fuels in an approved container (supplied bottle is for mixing only).

1. Fill with unleaded petrol (91 octane) up to fuel line.

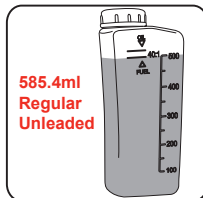

2. Add 2-stroke oil up to oil line. Shake sufficiently for a thorough mix.

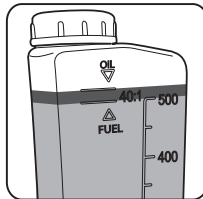

3. Fill the fuel tank to about 80% of its capacity with the fuel mix. Fuel tank capacity: 650ml

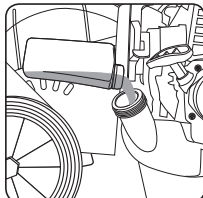

4. Fasten the fuel tank cap and clean any spillage.

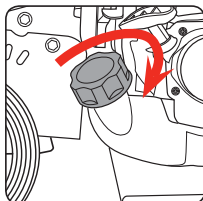

WARNING! NEVER ATTEMPT TO FUEL THE EDGER IF THE FUEL SYSTEM COMPONENTS ARE DAMAGED OR ARE LEAKING.

WARNING! ALLOW THE ENGINE TO COOL BEFORE FUELLING. NEVER ATTEMPT TO REFUEL THE ENGINE WHILE IT IS WARM OR STILL RUNNING.

WARNING! NEVER PLACE FLAMMABLE MATERIAL CLOSE TO THE ENGINE MUFFLER.

3. ADJUSTING CUTTING DEPTH

The edger has a height adjustment lever to easily adjust the cutting height.

There are 5 settings ranging between -20 to 30mm.

1. To decrease the cutting height pull the height adjustment lever out and move it up a notch, towards the handlebar.

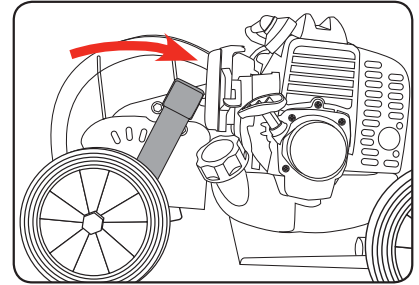

2. To increase the cutting height pull the height adjustment lever out and move it down a notch, towards the front of the unit.

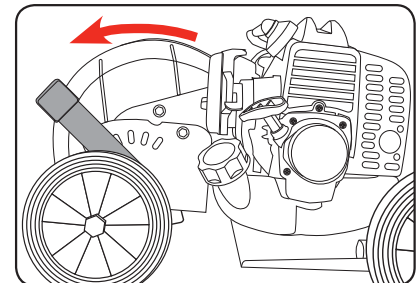

NOTE: If you are unsure of which cutting height to use, begin with a high setting and complete a trial cut on a small section of the lawns edge. Readjust if necessary.

OPERATION

4. STARTING & STOPPING

Starting

NOTE: Do not squeeze the throttle before starting.

1. Press the On/Off switch on the handle to the On (I) position.

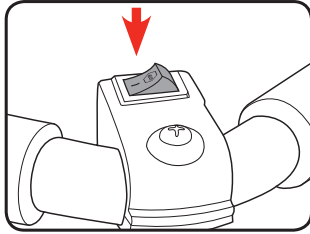

2. Press the primer bulb until full of fuel

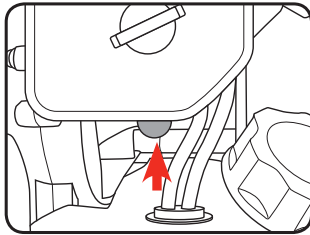

3. Push the choke lever up to the Choke position.

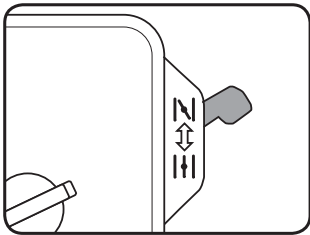

NOTE: Pressing the primer bulb and setting the choke to the start position is unnecessary if the engine is warm.

Cold Start position

4. Pull the recoil starter until the engine starts.

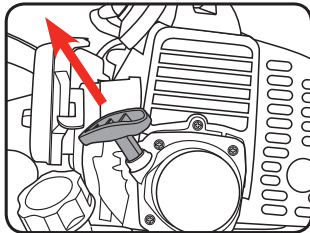

5. Push the choke lever down to the run position. Restart if the engine stops.

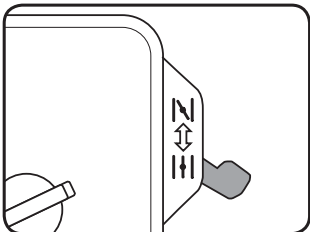

Warm Start position

6. Tilt the unit backwards, so that the blade is clear of the ground.

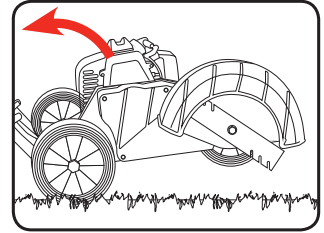

7. Release the safety then squeeze the throttle gently. Allow the engine to run for 60 seconds so that it warms up.

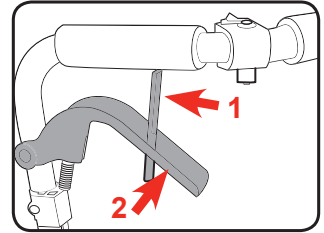

Stopping

1. When you wish to stop the engine, first release the throttle so that the engine is idling and the blade stops spinning.

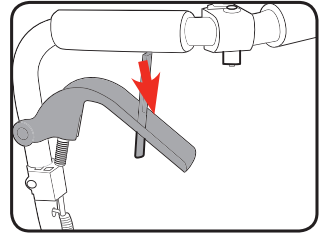

2. Press the On/Off switch to the (O) Off position, as indicated on the switch.

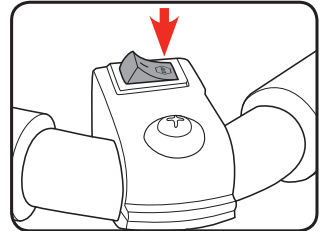

WARNING! THE LAWN EDGER RUNS FOR A FEW SECONDS AFTER IT HAS BEEN SWITCHED OFF. LET THE ENGINE COME TO A COMPLETE STANDSTILL BEFORE SETTING THE TOOL DOWN.

5. EDGING

WARNING! BEFORE EDGING, CHECK THAT THE AREA IS CLEAR OF ANY OBSTACLES AND OBJECTS THAT COULD BE THROWN.

NOTE: If the cutting depth needs adjusting, this should be done progressively until the desired depth is reached. Do not overload, keep initial cutting depth at minimum. If the edger slows, pull back slightly and wait until the blade returns to normal speed.

With the cutting height adjusted and the engine operating, edging can commence.

1. While the engine is idling, line up the lawn edger cutting blade with the edge to be cut. Use the arrow label on the blade guard to assist in guiding you where the cutting blade will cut.

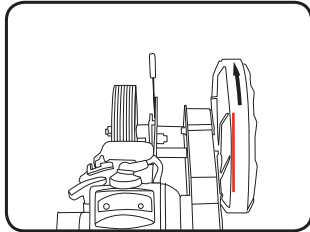

2. Before beginning to edge, tilt the handle down so the blade is above ground level. This assists in the prevention of kickback.

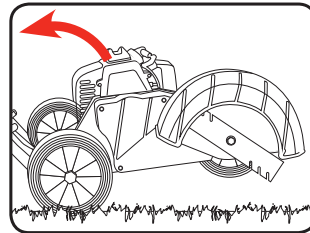

3. When starting to edge, release the safety and pull the throttle lever. Run the engine at full throttle and lower the blade gently into the ground. Be careful not to hit concrete with the blade.

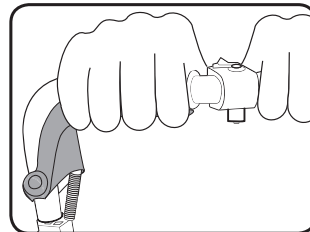

4. Walk forward slowly, keeping the cutting blade aligned with the edge to be cut. If the lawn edger begins to slow down due to a build up of grass in the blade guard, walk back slightly to allow the grass to fall out. Let the cutting blade return to normal speed before continuing forward.

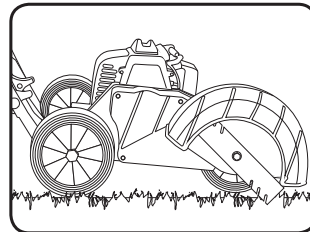

NOTE: Some sparks may be generated from the cutting blade while pressed against a solid edge (eg; concrete) to be cut, simply align the blade so no contact is made.

NOTE: If the blade guard becomes clogged, tilt the handle down so the blade is above ground level. This assists in clearing the debris from the blade and guard. If the debris does not fall out, stop the engine, wait for the blade to stop rotating and remove debris from the blade guard.

5. Continue on until you have successfully edged all sides of your driveway and footpaths etc.

6. Release the throttle lever. Press the On/Off switch to the Off (O) position and let the engine come to a complete stop.

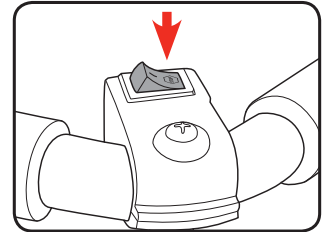

WARNING! THE ENGINE HOUSING MAY BECOME VERY HOT DURING USE. AVOID CONTACT DURING AND IMMEDIATELY AFTER OPERATION.

MAINTENANCE

6. CHANGING THE CUTTING BLADE

WARNING! BEFORE CLEANING YOUR PETROL EDGER OR CARRYING OUT ANY MAINTENANCE PROCEDURE, MAKE SURE THAT THE ENGINE IS OFF AND IS COOL. DISCONNECT THE SPARK PLUG TO PREVENT ACCIDENTAL STARTING

1. Lay the petrol edger on its side with the cutting blade facing up.

NOTE: The cutting blade rotates in anti-clockwise direction.

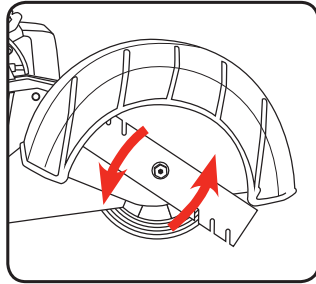

2. Hold the spindle in place with supplied hex key. Use the supplied spanner to remove the flange nut, by turning in an anti-clockwise direction.

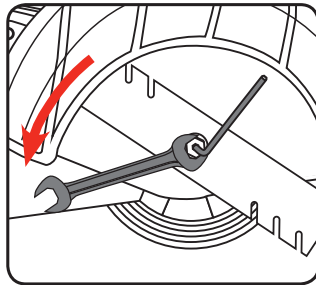

3. Remove the flange nut, and blade.

NOTE: Ensure that the inner flange and outer flange nut are clean of any dirt or grass prior to fitting.

4. Fit the new blade over the inner flange.

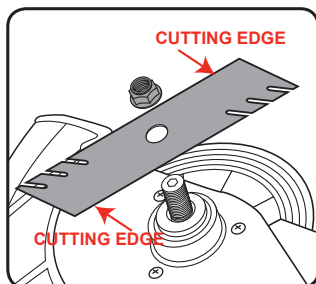

5. Fit the flange nut and tighten firmly using the open spanner supplied, in a clockwise direction. Use a 8mm hex key to stop the spindle rotating.

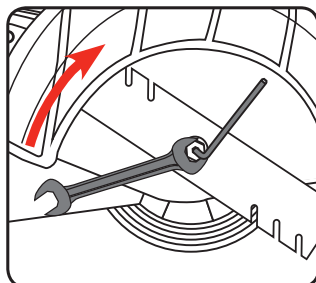

7. GENERAL MAINTENANCE

- Keep the ventilation vents of the tool clean at all times, if possible, prevent foreign matter from entering the vents.
- After each use, blow air through the engine housing to ensure it is free from all dust particles which may build up. Build up of dust particles may cause the unit to overheat and fail.
- If the enclosure of the tool requires cleaning do not use solvents but a moist soft cloth or soft brush only. Never let any liquid get inside the tool; never immerse any part of the tool into a liquid.

NOTE: Ozito Industries will not be responsible for any damage or injuries caused by the repair of the tool by an unauthorised person or by mishandling of the tool.

Air filter

1. Loosen the filter cover knob and remove the filter cover.
2. Remove the air filter, brush off any dry particles, or dislodge them by tapping the air filter on a hard surface.
3. Replace the air filter, air filter cover and air filter cover locking knob.

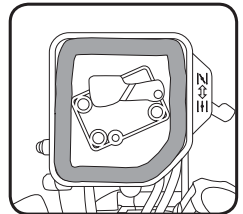
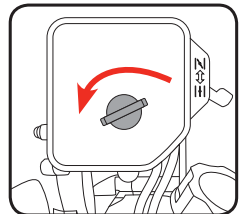

Replacing the spark plug

When the Petrol Edger will not start and everything has been checked, it is likely the spark plug will need replacing. The spark plug is not covered under warranty.

To replace the spark plug:

1. Pull the spark plug lead off the end of the spark plug.
2. Loosen (anti-clockwise) the spark plug using the larger socket side of the spark plug spanner provided.
3. Remove the spark plug and replace with a new one, as specified.

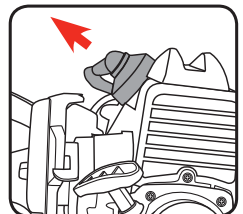

Spark plug: LD BM6A.

4. Secure the spark plug in position by tightening (clockwise) the spark plug using the spark plug spanner provided.
5. Fix the spark plug lead back to the end of the spark plug ensuring it clicks into place.

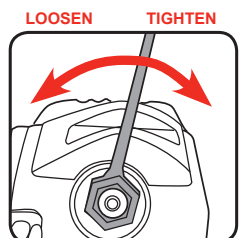

















PROBLEM SOLVING

Engine stopping suddenly or insufficient power

- Check that there is fuel in the tank.
- There may be water in the fuel mixture. Drain and rinse all the fuel system.
- The air filter may be filled with dust. Clean the air filter.

DESCRIPTION OF SYMBOLS

	Cubic Centimeters (the standard measure of displacement in Europe and Asia)		
	Revolutions or reciprocation per minute		No load speed
	Use at a distance of at least 15m from other people.		Regulator compliance mark
	Diameter		Warning
	Read instructions		WARNING. Rotating blades.
	Wear safety glasses		Wear muffs
	Thrown objects can cause severe injury.		Flammable material.
	Do not put hands or feet under the cover of the machine when it is running.		Extremely hot surface.
	Sound pressure level		

SPARE PARTS

Spare parts can be ordered from the Special Orders Desk at your local Bunnings Warehouse.

For further information, or any parts not listed here, visit www.ozito.com.au or contact Ozito customer service

Australia 1800 069 486

New Zealand 0508 069 486

E-mail: enquiries@ozito.com.au

CARING FOR THE ENVIRONMENT



Tools that are no longer usable should not be disposed of with household waste but in an environmentally friendly way. Please recycle where facilities exist. Check with your local council authority for recycling advice.



Recycling packaging reduces the need for landfill and raw materials. Reuse of recycled material decreases pollution in the environment. Please recycle packaging where facilities exist. Check with your local council authority for recycling advice.

SAFETY INSTRUCTIONS

RISK OF EXPLOSION OR FIRE

What can happen:

- Spilled petrol and its vapours can become ignited from cigarette sparks, electrical arcing, exhaust gases and hot engine components such as the muffler.
- Heat will expand fuel in the tank which could result in a fire.
- Operating the tool in an explosive environment could result in a fire.
- Muffler exhaust heat can damage painted surfaces, melt any materials sensitive to heat (such as siding plastic, rubber or vinyl) and damage live plants. Keep hot tool away from other objects.
- Improperly stored fuel could lead to accidental ignition. Fuel improperly secured could get into the hands of children or other unqualified persons.

How to prevent it:

- Shut off engine and allow it to cool before adding fuel to the tank.
- Use care when filling the tank to avoid spilling fuel. Move tool away from fuelling area before starting engine.
- Keep maximum fuel level 20mm below top of tank to allow for expansion.
- Operate and refuel in well ventilated areas free from obstructions.
- Store fuel in a approved container (AS/NZS 2906-1999) for petrol. Store in a secure location away from the work area. Make sure the container is clearly marked "fuel".

RISK TO BREATHING

What can happen:

- Breathing exhaust fumes can cause serious injury or death. How to prevent it:

How to prevent it:

- Operate tool in a well ventilated area. Avoid enclosed areas.
- Never operate unit in a location occupied by other people or animals.

SAVE THESE INSTRUCTIONS

1) Work area

- a) **Keep work area clean and well lit. Cluttered and dark areas invite accidents.**
- b) **Do not operate petrol tools in explosive atmospheres, such as in the presence of flammable liquids, gases, or dust.** Power tools create sparks which may ignite the dust or fumes.
- c) **Keep children and bystanders away while operating a petrol tool.** Distractions can cause you to lose control.

2) Personal safety

- a) **Stay alert, watch what you are doing and use common sense when operating a petrol tool.** Do not use a power tool while you are tired or under the influence of drugs, alcohol, or medication. A moment of inattention while operating power tools may result in serious personal injury.
- b) **Use safety equipment. Always wear eye protection.** Safety equipment such as a dust mask, non-skid safety shoes, hard hat, or hearing protection used for appropriate conditions will reduce personal injuries.

- c) **Remove any adjusting key or wrench before turning the tool on.** A wrench or a key that is left attached to a rotating part of the petrol tool may result in personal injury.
- d) **Do not overreach. Keep proper footing and balance at all times.** This enables better control of the petrol tool in unexpected situations.
- e) **Dress properly. Do not wear loose clothing or jewellery.** Keep your hair, clothing and gloves away from moving parts. Loose clothes, jewellery or long hair can be caught in moving parts.
- f) **If devices are provided for the connection of dust extraction and collection facilities ensure that these are connected and properly used.** Use of these devices can reduce dust-related hazards.

3) Petrol tool use and care

- a) **Do not force the petrol tool. Use the correct petrol tool for your application.** The correct petrol tool will do the job better and safer at the rate for which it was designed.
 - b) **Do not use the petrol tool if the switch does not turn it on and off.** Any petrol tool that cannot be controlled with the switch is dangerous and must be repaired.
 - c) **Turn tool off completely before making any adjustments, changing accessories, or storing petrol tools.** Such preventive safety measures reduce the risk of starting the petrol tool accidentally. Hair can be caught in moving parts.
 - d) **Store idle petrol tools out of the reach of children and do not allow persons unfamiliar with the petrol tool or these instructions to operate the petrol tool.** Petrol tools are dangerous in the hands of untrained users.
 - e) **Maintain petrol tools. Check for misalignment or binding of moving parts, breakage of parts and any other condition that may affect the petrol tool's operation.** If damaged, have the petrol tool repaired before use. Many accidents are caused by poorly maintained petrol tools.
 - f) **Keep cutting tools sharp and clean.** Properly maintained cutting tools with sharp cutting edges are less likely to bind and are easier to control.
 - g) **Use the petrol tool, accessories and tool bits etc., in accordance with these instructions and in the manner intended for the particular type of petrol tool, taking into account the working conditions and the work to be performed.** Use of the petrol tool for operations different from intended could result in a hazardous situation.
 - h) **This appliance is not intended for use by persons (including children) with reduced physical, sensory or mental capabilities, or lack of experience and knowledge, unless they have been given supervision or instruction concerning use of the appliance by a person responsible for their safety.**
 - i) **Children should be supervised to ensure that they do not play with the appliance.**
- ### 4) Service
- a) **Have your petrol tool serviced by a qualified repair personnel using only identical replacement parts.** This will ensure that the safety of the petrol tool is maintained.

ADDITIONAL SAFETY INSTRUCTIONS FOR PETROL EDGERS

Even when the tool is used as prescribed it is not possible to eliminate all residual risk factors. The following hazards may arise in connection with the tool's construction and design:

- Contact with the blade.
- Kickback of the edger due to hidden solid objects.
- Blade fracture.
- Catapulting of blade pieces.
- Damage to hearing if effective earmuffs are not worn.
- Do not use blades that are deformed or cracked.
- Do not operate in a hazardous location. Such areas include where there is a risk of explosion of petrol fumes, leaking gas or explosive dust.
- Do not operate in a confined area. Exhaust gases, smoke or fumes could reach dangerous concentrations.
- Protect your tool. This edger is NOT WEATHERPROOF and should not be exposed to direct sunlight, high ambient temperature and damp, wet or high humidity conditions.
- Do not smoke while refuelling. This is potentially dangerous as it may ignite the fuel and cause an explosion.
- Take care not to spill fuel. When refuelling the edger ensure that the motor has been switched off. Prevent the spilling of fuel as this may also ignite with the hot motor. Never refuel whilst the engine running.
- Be careful where you store the edger. Store the edger in a dry area away from flammable liquids.
- Keep your distance. The edger emits exhaust fumes. Ensure bystanders keep a safe distance.
- Ensure you use oil-mix fuel. Ensure that you mix 40 parts unleaded fuel to 1 part engine grade oil. If not, the engine will overheat and cause damage to your edger.
- Never fill fuel tank indoors. Never fill fuel tank when engine is running or hot. Do not smoke when filling fuel tank.
- When making any adjustments to the tool always wait for the blade to come to a complete stop and turn off the tool.

- Never attempt to unclog the blade chamber by tapping the tool on the ground, this can damage the unit.
- Keep hands clear of edge guide and blade when cleaning as these wear to a very sharp point during edging.
- Before landscaping or trenching, inspect and ensure there are no exposed or buried cables or pipes or other objects that may create a hazard or interfere with operating the edger.
- Set depth to only that required for the job, do not overload. If tool slows, pull back slightly and wait until blade returns to normal speed.
- Check damaged parts before further use of the appliance, a guard or other part that is damaged should be carefully checked to determine that it will operate properly and perform it's intended function. Check for alignment of moving parts, binding of moving parts, mounting, and any other conditions that may affect it's operation.
- Ensure guards are kept in place.
- Always keep blade area clean.
- When using the edger, stones, pieces of metal and other objects can be thrown out at high speed by the blade. The tool and guard are designed to reduce the danger. However, the following special precautions should be taken:
 - Wear safety glasses or other eye protection, gloves, long pants and suitable footwear.
 - Make sure that other people and pets are at least 5 metres away.
 - Always stand to left side of main handle.
 - Before landscaping or trenching, check for buried electrical cables.
 - To reduce the risk of injury, work going away from nearby solid objects such as walls, steps, stones, trees etc. Use great care when working close to solid objects, and where necessary, do edging or trimming by hand.
- Use only blades as recommended.
- Do not attempt to free a jammed blade before first switching off the machine.
- Let the blade come to rest naturally.
- Periodically check that all fixings are properly tightened.