

## ASSEMBLY INSTRUCTIONS FOR EXB-5C AND EXB-4J

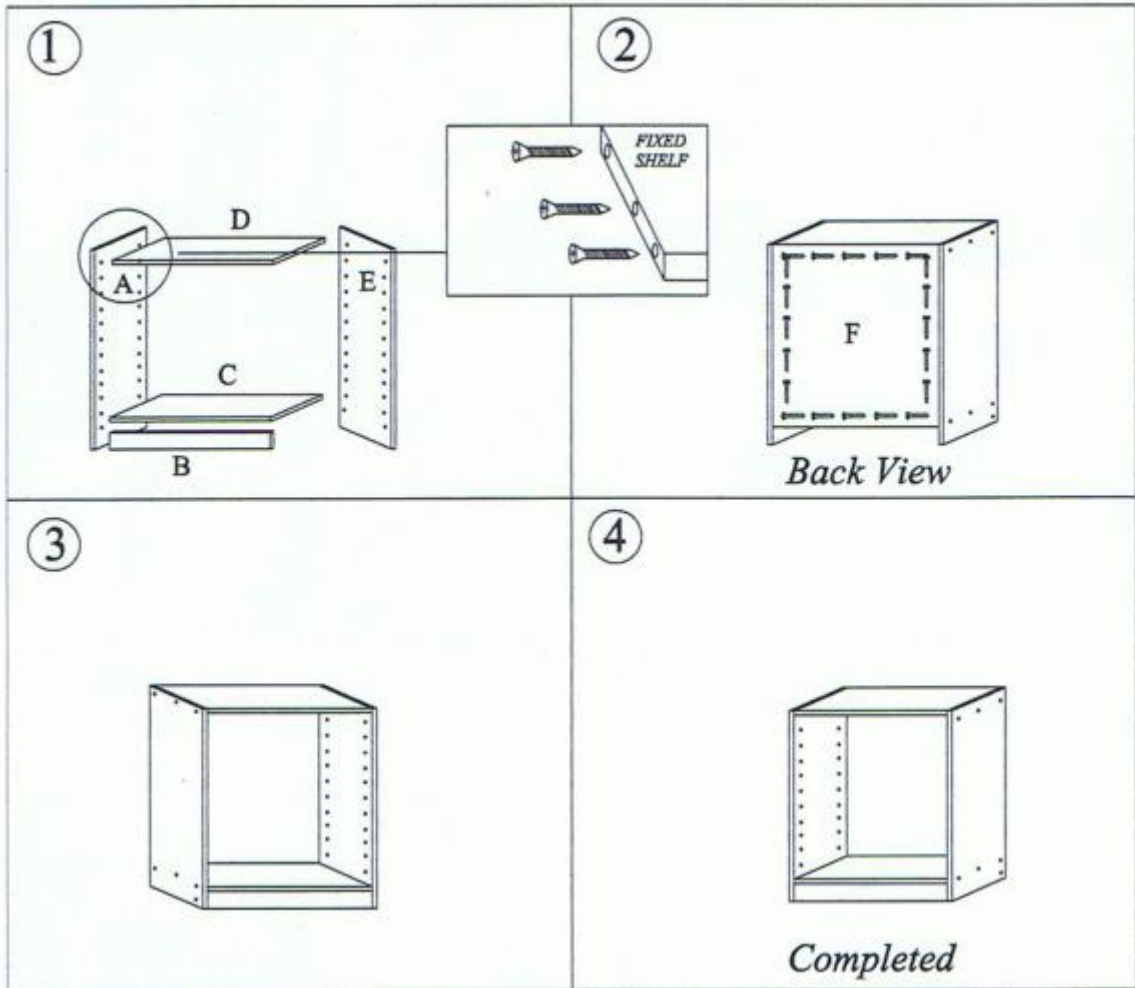

## HARDWARE LIST

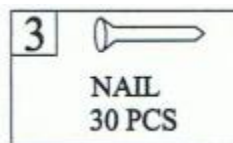

## ASSEMBLY INSTRUCTIONS FOR DRAWER BOX AND METAL RUNNER

### STEP 1.

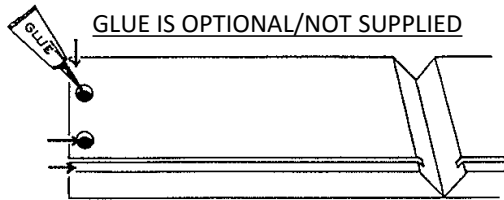

CAREFULLY REMOVE DRAWERS FROM THE CARTON AND LAY FLAT ON THE FLOOR. PLACE A FEW DROPS OF WOOD GLUE (NOT SUPPLIED) IN DOWEL HOLES AND V JOINTS (REFER DIAGRAM)

### STEP 2.

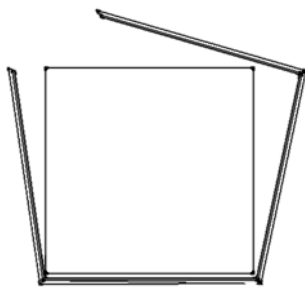

DRAWER BOTTOM

PLACE THE DRAWER BOTTOM INTO GROOVE ON THE DRAWER WITH THE WHITE SIDE TO THE TOP OF THE DRAWER. GENTLY FOLD THE REMAINING SIDES AROUND THE DRAWER BOTTOM UNTIL DOWELS ARE ALIGNED WITH HOLES, PUSH DOWN FIRMLY AND WIPE OFF ANY EXCESS GLUE FROM JOINTS.

### STEP 3.

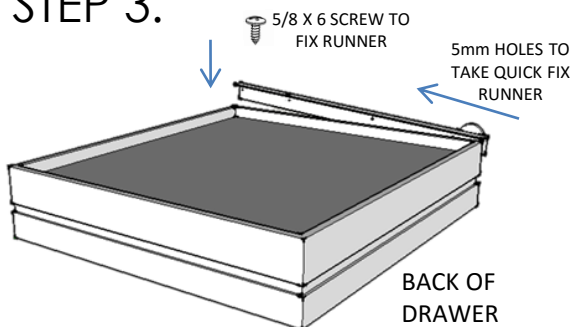

TURN DRAWER BOX UPSIDE DOWN. TAKE RUNNER, INSERT THE TAB INTO 5mm HOLE IN BACK OF DRAWER PUSH FORWARD AND THEN PUSH DOWN SO THE FRONT OF THE TAB WILL ALIGN WITH 5mm HOLES IN THE FRONT OF THE DRAWER ONCE FIRMLY IN PLACE USE 5/8 X 6 SCREWS PROVIDED TO FIX RUNNER.

### STEP 4.

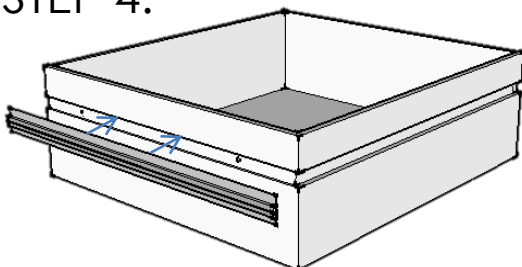

BY USING THE 12mm X 5mm BOLT SUPPLIED INSERT INTO 5mm PRE-DRILLED HOLES IN FRONT OF DRAWER. ALIGN THE ALUMINIUM HANDLE WITH ONE END OF THE DRAWER AND TIGHTEN SCREW. DO THE SAME FOR THE OTHER END. DO NOT OVER TIGHTEN SCREWS.

---

## WARRANTY

---

Our goods come with guarantees that cannot be excluded under the Australian Consumer Law. You are entitled to a replacement or refund for major failure.

### 5 Year Warranty

- If the purchaser has a fault or defect with this product, the purchaser needs to contact Multistore Industries (AUST) directly on (07) 3208 6799 and state date of purchase, place of purchase and proof of purchase.
- Multistore Industries (AUST) will replace any faulty or defect parts at no cost to the customer. A replacement will be sent to you as soon as possible, or product can be exchanged at the store of purchase.
- This warranty is in addition to other rights and remedies of the customer under law.

Sincerely,

Multistore Industries (AUST) Management