

Scandia Heat & Cook

Slow Combustion Stove

Model Name

Heat & Cook

Model Number

SCX501

Introduction

Congratulations on purchasing a genuine Scandia Wood heater. When cared for properly, these high quality, finely crafted wood heaters will offer many years of reliable performance. This instruction manual has been developed to ensure optimum performance from your Scandia wood heater. It's very important that you thoroughly read and understand all instructions before using your new wood heater.

Check Local Council Requirements Eg. permits

When installing, operating and maintaining your wood heater, follow the guidelines presented in these instructions, and make them available to anyone using or servicing the wood heater. Your city, town, state or territory may require a building permit to install a solid fuel burning appliance.

Always consult your local building inspector or local council to determine what regulations apply in your area.



*Your wood heater **must** be installed by a qualified person whose work conforms with local council regulations, Australian standards & manufacturers recommendations. Failure to do so will void your warranty and could possibly void any home insurance.*

Wood Heater Safety

When properly maintained and operated your wood heater should give you many years of service, however there are important safety aspects of these products that you need to be aware of when operating a wood heater.

1. *This appliance is not intended for use by persons (including children) with reduced physical, sensory or mental capabilities, or lack of experience and knowledge, unless they have been given supervision or instruction concerning use of the appliance by a person responsible for their safety.*
2. *Children should be supervised to ensure that they do not play with the appliance.*
3. *If the electrical supply cord is damaged, it must be replaced by the manufacturer, its service agent or similarly qualified persons in order to avoid hazard.*
4. *Never place combustible items such as but not limited to furniture, fabric or wood within the specified clearances to combustibles.*
5. *The burning of wood gives off gases which can be extremely dangerous. Wood heaters are designed so that under normal operating circumstances these gases pass up the flue chimney system and cannot escape into your home, however it is important that your flue system is properly installed and that you check all joints regularly to ensure that there are no cracks or gaps, check the door sealing rope and replace when damaged. We recommend a smoke alarm be fitted in rooms where wood heaters are installed. Do not use wood heater in a room where negative pressure conditions may occur, such as through the use of extraction fans unless an adequate air supply into the room is ensured, as this may draw air through the wood heater and cause products of combustion to escape into the room.*
6. *This appliance is designed to specifically burn dry hardwood. Do not burn rubbish, driftwood, flammable liquids or any substance containing salts or corrosives.*
7. *Creosote and soot may accumulate in your flue pipe and chimney. This may ignite, causing a chimney fire. If you suspect a chimney fire close down the air controls on the wood heater, if the fire persists evacuate people from the building and call the Fire Brigade. To prevent the accumulation of soot or creosote, check flue and chimney regularly and clean as necessary. Good burning, hot wood heaters will generally cause a lot less build-up than slow burning wood heaters, likewise dry wood will cause less build-up than wet wood. We recommend a fire extinguisher be available where wood heaters are in operation. In the event of a chimney fire do not re-light the wood heater until it and the flue chimney system have been thoroughly checked and repaired as necessary.*
8. *Wood heaters get extremely hot and should not be touched when lit. When young children are in the area, we recommend the use of a suitable fire guard around the wood heaters. Always wear protective gloves when reloading wood heater.*
9. *Never over-fire your wood heater. If external parts of your wood heater are glowing red then the wood heater is over-firing and your draught settings should be reduced. Never interfere with the draught mechanisms or adjust your air settings outside those limits set when the wood heater is manufactured. Never use a fan to supply air to the wood heater or to extract air from it.*
10. *All users of the wood heater should be aware of the contents of this manual. Please leave this manual where it is accessible to wood heater users and do not allow anyone to use the wood heater that is unfamiliar with its correct operation.*
11. *Never use the wood heater if any parts are missing or damaged, only use genuine parts as replacements. Never modify your wood heater.*

Before Installing your wood heater

You need to consider the following to ensure the safe operation of your wood heater.

Provision of adequate air to support efficient combustion of the fuel.

A well sealed flue/chimney system, hereinafter referred to as the "flue system".

The protection of combustible materials in proximity of the wood heater.

A suitable base on which to place your wood heater.

Adequate provision air

It is essential for the safe and efficient use of your wood heater that you provide an adequate air supply to your wood heater. This may mean the provision of an outside air supply to the room, especially if there are extraction units such as cooker hoods or clothes dryers in the vicinity. Failure to do so will mean that fuel is burned inefficiently causing smoke and blackening the glass and may also cause smoke to come back into the room. As a simple check for this open a door or window in the room and check if the wood heater burns more efficiently.

Well sealed flue system

Under no circumstances should you use aluminum or galvanized steel pipes for your wood heater flue.

Always fit pipes with the narrow crimped side down, this allows any creosote to run down the inside of the pipe and not to come out and cause an unsightly mess and possible fire hazard.

Pipe bends should be kept to a minimum and we do not recommend using more than 2 bends on any installation. Flues must not pass through ceilings, floors, attics, roofs, or combustible walls without adequate and approved insulation being provided to protect combustible materials.

The chimney and flue provide a means of taking combusted fuel from the wood heater, as well as a draught to enable the wood heater to work. It is essential that the flue system is kept in good condition and there are no breaks or cracks allowing contact with any other combustible materials of the house. It is also essential that the flue system is kept clean and seals are maintained to ensure the draught is not lost.

The open end of the flue system must be above the height of the apex of the building and any other obstructions, such as trees, which are within 3 meters (10ft) of the flue system. Failure to do this will affect the efficiency of the wood heater and may cause down draughts which will mean dangerous products of combustion are emitted into room.

Under no circumstances should the flue pipe be less than 6" (152mm) internal diameter.

Clearances to combustibles

It is extremely important that you respect required installation distances and that you respect local installation regulations. This is for your safety! The manufacturer is not responsible for the product, if it is not installed following these recommendations. These clearances may only be reduced by means approved by the regulatory authority. Cont..

A combustible surface is anything that can burn (i.e. plaster, wall paper, wood, fabrics etc.) These surfaces are not limited to those that are visible and also include materials that are behind non-combustible materials. If you are not sure of the combustible nature of a material, consult your local fire officials.

Hearth requirements

The floor protector must consist of 30.0mm thick cement fibre sheet which has a thermal resistance of 0.8m² K/W, per 4mm thickness or equivalent. Scandia have a complete range of suitable ready to install hearth pads for straight wall and corner installations.

Installation

Warmbrite Clearances to Combustibles

Parallel Installation

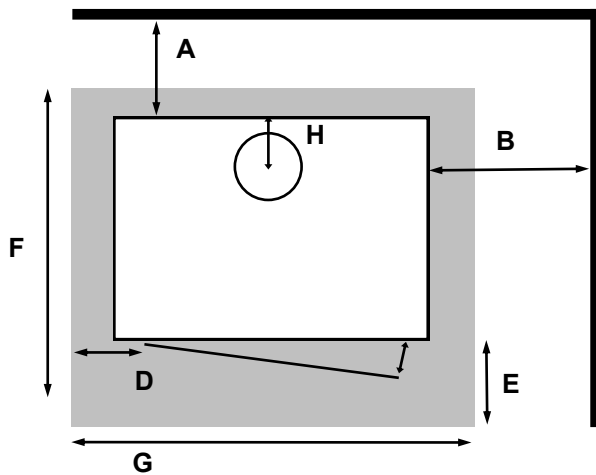

Corner Installation

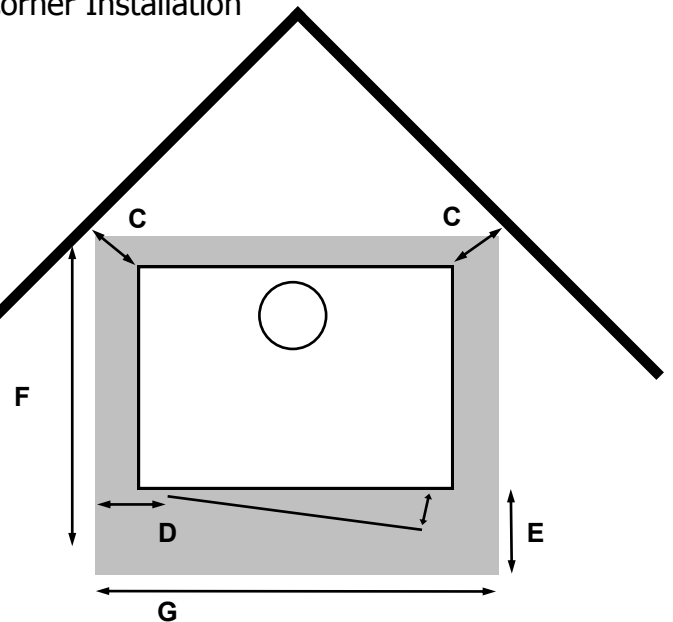

	SCX501
A – Rear of heater to rear wall	175mm*
B – Side of heater to side wall	425mm
C – Rear corner of heater to wall	200mm*
D – Hearth to door hinge	200mm
E – Front of heater to hearth front	300mm
F – Minimum hearth depth	900mm
G – Minimum hearth width	820mm
H – Rear of heater to centre of spigot	112mm

*with decorative flue, with at least 180° heat shield and 900mm 180° flue shield in place.

For connecting into a standard installation using Scandia Default Flue Kits:

The following drawing is meant as a guide only. Your wood heater **must** be installed by a qualified person whose work conforms with local council regulations, Australian/New Zealand standards (AS/NZS 2918:2001) & manufacturers recommendations.

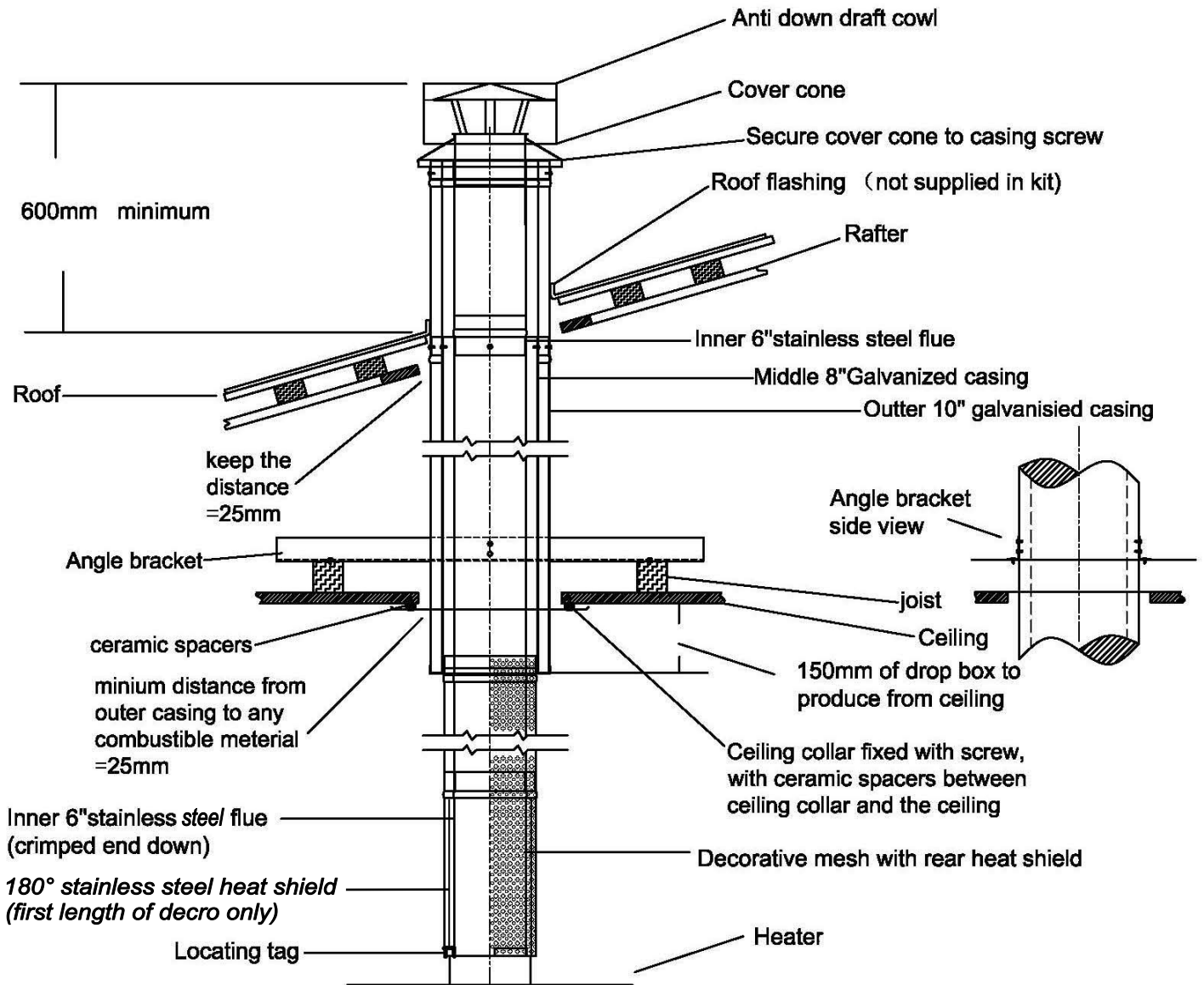

1. Locate wood fire in its proposed position according to manufacturers recommendations.
2. Use a plumb bob to mark the ceiling in line with the centre of the flue collar.
3. Check that the outer casing will clear all combustible materials by 25mm. Determine positions of noggins to avoid cutting, otherwise headers must be installed for strength.
4. Cut a 305mm diameter hole in the ceiling. Directly above cut a hole in the roof to accommodate outer casing.
5. Fix the angle brackets to the joists so that the drop box (first length of located casing) is located in the centre of the hole.

6. *Position the drop box between the angle brackets, keeping a 25mm clearance to combustibles. The located end of the drop box must protrude no less than 150mm down from the ceiling. Fix the drop box to the angle brackets.*
7. *Add the remaining casings to the required height. Australian/New Zealand Standards state that "the flue pipe shall extend not less than 4.6m above the top of the floor protector". If the flue pipe is within 3 metres of the ridge, the flue pipe must protrude at least 600mm above the ridge of the roof. If the distance from the ridge is more than 3 metres, the flue pipe must protrude at least 1000mm above roof penetration. Additional lengths of casing and flue may be required to achieve this. The flue pipe must be more than 3 metres from any nearby structure. Other clearances may be applicable, it is up to the installer to ensure compliance with all regulations.*
8. *Install roof flashing (optional accessory).*
9. *Secure the Ceiling Collar in place using ceramic spacers and screws provided.*
10. *Insert crimped end of the upper decorative flue (without internal stainless steel heat shield) up into the drop box. Then insert the crimped end of the lower decorative flue (with the internal stainless steel heat shield) up into bottom of the upper decorative flue. The lower decorative flue features locating tags on the non crimped end which rest on the heater flue collar. The solid heat shield section of the decorative mesh and stainless steel inner heat shield is to face the wall.*
11. *Feed stainless steel flue through decorative flue and drop box through to the required height. Assemble flue pipes tight together as you go ensuring seams are straight. Secure each joint with three stainless steel rivets spaced equally. Clean any finger prints or oils off stainless steel flue with methylated spirits.*
12. *Trim the inner flue to the same height as the outer casing. Place cover cone and cowl over stainless steel flue & push cover cone over gal casing. Fix with stainless steel pop rivets.*

For connecting into existing masonry chimney:

The Chimney should be swept prior to installation. The Chimney must not have any hollow sections present. The connecting flue pipe must be sealed to the chimney with fire cement and high temperature resistant rope as required. This is usually done into a register (Blanking) plate with an access door/hatch to enable chimney sweeping. Flue pipe must continue for the full length of the chimney. The top must be suitably weather sealed with a chimney to flue pipe adaptor sealed in place with mortar. The flue must be completed with a cowl. Note there should not be any flue exposed to the elements.

Operating Your Wood Heater

Fuel

Your wood heater is designed to burn dry hardwood only.; it is not designed to burn,

- Soft wood
- Paper or cardboard, other than small amounts used to light stove.
- Treated or painted wood
- Synthetic fuel or logs that are not approved for solid fuel stoves
- Household rubbish
- Liquid fuels
- Plastics

Burning these or other products for which the wood heater was not designed may damage the wood heater and cause a fire hazard or release toxic fumes.

Fuel should be stored in a dry place; wood should be dried for at least 1 year and have a moisture content of no more than 20%. Wet wood may cause serious creosote, which may damage your flue system and even your wood heater. Therefore the use of wet wood is strongly discouraged.

Controls and their use

- 1. Flue Damper** - Aids in lighting fire. Back = Open, Forward = Closed.
- 2. Primary Air Inlet Control** - Provides primary air intake to regulate burn rate of fire and keep glass clean.
- 3. Secondary Air Inlet Control** - Provides secondary air intake directly to coal base to further regulate burn rate of fire.
- 4. Oven Temperature Control** - Provides cool air to oven to further regulate oven temperature. (Burn rate of fire will be the main temperature regulation).



First operation of stove

Warning: When operating, this unit will get extremely hot. Do Not Touch, use tools where necessary.

You should begin using your wood heater by lighting small fires which get progressively larger. We recommend lighting approximately 5 small fires before you put the wood heater into full service. Allow the wood heater to fully cool between each of these fires. There may be some smell and a small amount of smoke from the wood heater during the initial operations. This is perfectly normal and is merely the curing of the wood heater paint. Opening a window or door to provide additional ventilation will help alleviate this.

Air controls

Your wood heater needs air to burn the fuel, on this range this is supplied in two locations. The primary air slide at the right side of the front of your wood heater above the door and the secondary air slide at the bottom of the firebox door.

Primary air, as the name suggests, is used for the initial burning of the fuel and is also used to keep the stove glass clean. Secondary air is used for secondary combustion, which makes the stove more efficient, reduces the emissions by introducing air directly over the fire bed.

The settings of the primary and secondary air control very much depends on draught and local conditions and after a few fires, you should have a good idea of the best settings for your stove. Both air slide controls should be fully opened when lighting the fire. Once the fire is established, the primary air can be adjusted to where the glass remains clean and the secondary air control may be adjusted as required. Reducing the air intake will cause the wood heater to burn slower. This may cause some blackening of the stove glass, but this should burn off once the wood heater is burning brightly again.

The flue damper must be kept closed except when lighting the fire. If oven is too hot for cooking lower temperature quickly by opening the oven temperature control and the flue damper until required heat is reached and then close. Adjust air controls so temperature is maintained. Keep the firebox door closed securely at all times except when de-ashing the fire or reloading wood.

Keep all combustible materials at least 1.22 metres (4 feet) away from the range. They include rugs, fabrics, furnishings, papers, firewood, etc. NEVER dry clothing on or within 1.22 metres of the range.

Lighting the fire

Open the fire door, lay a few crumpled sheets of paper on the firebox base then a few small dry pieces of sticks or kindling. Open the flue damper fully by pushing backwards. Open both the air inlet controls. Now light the paper, close the fire door when the kindling has caught fire (allow about 10 minutes for this to happen) add larger pieces of dry wood, until the fire box is half filled. When the larger pieces of wood have caught fire, add full sized logs, close the flue damper. Close the air controls to the point where the required burn rate is obtained. Season the range gradually.

Refueling

Before refueling your wood heater, turn the air supply to high for a few moments until there is a good fire in the heater. This will ensure there is no build-up of harmful gases in the wood heater when the door is opened and will also get the new fuel burning quickly and not allow it to kill the fire. Open the door slowly in case any logs or coal have fallen against the glass. Opening the door quickly may result in smoke being drawn into the room.

To reload the wood heater, open the door and feed the fuel in slowly always using either tongs, a small shovel along with protective gloves. Do not overfill the wood heater. It is always better to put in small loads often rather than big fills less frequently. Wood should be loaded in a front to back direction, this helps air flow as well as reducing the risk of logs falling forward. Close the door gently after wood heater is reloaded.

Overnight burning

Your wood heater is designed to support overnight burning. Best results are achieved when you establish a good fuel bed in the wood heater and allow it to burn for about 30 minutes before closing the air slide control fully.

When you return to your wood heater, fully open the air slide control until you have a good fire and then set to normal operating levels. Do not add fuel until the fire bed is hot and red. Then add a little for the first time and allow that to ignite before adding more. During overnight burning, the wood heater glass may blacken, but when a hot fire is established again this should burn off.

Wood Heater Maintenance

Check your wood heater regularly

Initially, we recommend you check your flue system at least once per month. After the first few months you will notice a pattern of soot and creosote build up and you can then determine an inspection interval for checking soot and creosote build up that is suitable for your wood heater installation.

Other checks, as listed below, should be carried out at least twice per year. If you notice anything wrong at any time it should be repaired immediately. Never use a wood heater that is in any way damaged or has a damaged flue.

- 1. Check your flue system for build up of soot or creosote and for signs of damage to joints.*
- 2. To check flue outlet remove top of baffle by lifting and pulling out at end. Use a flashlight to check flue outlet. Clean and repair as necessary. Always replace top baffle before relighting stove.*
- 2. Check that glass is not cracked or chipped and that the sealing rope is in good condition. Replace as necessary.*
- 3. When the room is dark, use a strong flashlight to check the sealing of the wood heater at the edge and corners for leaks. Any leaks or cracks found should be repaired with fire cement or damaged parts should be replaced with genuine spare parts.*
- 4. Check that wood heater door is tight and well sealed when closed. Place a strip of paper into the wood heater and close the door, try to pull out paper. You should feel some resistance to your pull, check several points around the door. If it pulls out too easily, replace the rope and seal in place with a suitable high temperature sealant.*

Ash removal

When the stove is out and completely cold you may remove the ash into a steel bucket with a small shovel. Place a cover over the bucket so that when removing the bucket the ash does not blow about your house.

Hot Water Generator (Optional)

According to Australian law this appliance must be installed by a registered plumber. Be sure to always have water running through your system, failure to do so will result in damage to hot water generator. When installing the plumber must use radial bends and always have the hot water line from the hot water generator to the storage unit inclining. Failure to comply with any of the above will negate warranty.

Warning: Do not cap off hot water outlets!!

Cleaning Instructions

Warning: Before beginning to clean your stove make sure the unit is not in use and is cold. It is advised that you put some plastic down on the floor in front of the stove whilst cleaning to prevent any creosote or ash from falling on the floor.

Step 1. Remove rear cleaning port cover located on the top plate to the left hand side. Push the cleaning tool down the back of the stove moving it about to loosen any built up creosote or ash. These loose particles will fall to the bottom into the ash drawer.

Step 2. Remove hot plate and push cleaning tool down each side of the outside of the fire box past the oven, move cleaning tool about to loosen any built up creosote or ash. These loose particles will fall to the bottom of the stove.

Step 3. Open the oven door and remove the ash drawer and dispose of ash carefully. Make sure the ash/creosote is cold. If the stove was particularly full of creosote once the ash drawer is removed additional creosote may fall into the compartment. Scrape this out also. Make sure sides and back are clear before putting stove back into service.

Care of glass

At times, especially when the air controls are turned to low settings or when damp wood is used, the wood heater glass will blacken. This is caused by fuel that is not completely burnt, but the build-up on the inside of the glass will normally burn off when a good hot fire is established in the wood heater.

There may be times however when you need to clean the glass. To do this, use a soft cloth and a non-abrasive glass cleaner. Only ever clean the glass when the wood heater is cold. When loading fuel into the wood heater, always make sure it is not protruding out through the door opening, as this may break the glass when you close the door. This is especially relevant when loading logs. Always close the door gently.

If the glass does crack when the wood heater is lit, let the fire die out. Do not open the door until the wood heater has fully cooled. Replace the glass with the specified replacement part before re-using the wood heater.

Door Adjustments

Door closing tension adjustment - As door seals age the seal beds into the heater body, this will allow air to be drawn in any gaps created. Remove the grub screw from the door handle shaft on the inside of the door, this will allow the handle to rotate 360°. Rotate the handle 1 full turn anti-clockwise and shut the door. Repeat this step until the door offers a little resistance to close. Replace the grub screw. Over tightening may cause the door to distort and break the glass.

Replacing parts

Always use genuine replacement parts. Only ever make replacements when the wood heater is cold. All replacement parts can be ordered from www.scandiastoves.com.au.

Surface finish

Your wood heater should only be cleaned using a damp cloth. Some cleaning products may leave stains on the wood heater surface. Never use abrasive cloths as these may scratch the surface. Painted wood heaters can be re-painted by using a good quality, high temperature wood heater paint. When re-painting, make sure there is plenty of ventilation and follow the manufacturer's instructions. Allow the paint to fully dry before lighting the stove and allow extra ventilation for the first couple of fires as some fumes may emit from the stove as the paint cures.

Trouble Shooting

Fire not burning

A wood heater not burning is generally caused by either a shortage of air and/or incorrect or damp fuel. If fuel is not the problem check:

- *That the air controls are opened.*
- *There is no blockage in the flue system.*
- *That the open end of the flue is above the height of any nearby obstructions.*
- *That there is a sufficient air supply into the room and that this supply is not being taken by an extractor fan.*

Glass blackens

Glass usually blackens when:

- *The fuel is not being burned efficiently because of starvation of air.*
- *Bad quality or damp fuel is being used.*

For optimum efficiency always use a good quality dry hardwood.

Smoke in room

If the wood heater is properly installed it should not emit any smoke into your room. Should this happen, check that your room is not air tight. This can easily be checked by opening a door or window. If the smoking stops you need to provide an additional air supply into the room. If this is not the problem, check if your chimney is blocked or obstructed and that you are not getting a down draught caused by the location of the open end of the flue pipe or chimney.

If the problem persists contact your dealer and ask him to get your chimney and stove Installation checked.

Fire burning too quickly

This is usually caused by too much draught or air.

- *Firstly try reducing the air supply to the wood heater by closing down your air controls, if this fails then you may have to adjust the door or you may have damage to the sealing.*
- *Close a thin strip of paper in the door, check to see if the paper stays in place or pulls out. If the paper pulls out easily you may need to adjust or replace the door seal.*
- *Check to see if the glass moves within the door frame. If it does you may need to tighten the glass retainer screws.*
- *Check the condition of the door sealing rope and the glass seal tape.*

Chimney fire

Chimney fires occur when soot and creosote that have built up in the flue system ignite. If the wood heater is operated properly and the flue checked and cleaned regularly then chimney fires should not occur. These fires can be very dangerous and must be avoided. Try to maintain good, hot fires in the wood heater whenever possible and at least once in every firing open the air controls and allow the wood heater to burn on full for a short while until the entire fire bed is glowing red. Check your flue system regularly for build-up of soot and creosote and clean as necessary. Chimney fires can be detected by sparks coming from the top of the chimney, a roaring sound coming from the area of the stove or chimney or vibration in the stove or chimney. In the event of a chimney fire, close the air controls, evacuate the building and call the fire department. Do not relight the stove after a chimney fire until the stove and flue have been checked and any necessary repairs have been carried out.

2. Exclusions

This Warranty does not apply:

- *where the defect is not due to the original design or manufacture of the part (including where the wood heater, part or accessory has been subject to accident, abuse, alteration, misuse or neglect or has been installed, inspected, operated or maintained negligently or not in accordance with applicable local laws and regulations and the manufacturer's printed instructions, if any);*
- *where the firebricks, top baffle or fibreglass seal have not been replaced after becoming damaged or worn;*
- *if You are not a retail purchaser, or in the case of non domestic use (e.g. pubs, clubs);*
- *to any accessories or optional parts;*
- *to any glass, paint, firebrick, fibreglass seal sold or used with the wood heater; or*
- *to any surface rust which may occur in transit, storage or use.*

3. How to make a claim

Any claim under this Warranty must be in writing to our mail address below. It must be sent within the applicable warranty period and must state:

- *the model and serial number of the wood heater;*
- *the place, price and date of purchase; and*
- *reasonable details of the defect.*

To obtain replacement or repair under this Warranty, the wood heater must be returned to the original place of purchase (and collected from there once the replacement or repair is complete) at Your cost. Scandia will not be responsible for any associated freight, disconnection or reinstallation costs (including labour costs). Scandia will only be responsible for transport of the wood heater from the original place of purchase to Scandia's premises (and back), and replacement or repair in accordance with this Warranty.

4. Contact details

Our contact details are:

Business and Mail address: 306 South Gippsland Hwy, Dandenong South, Victoria, 3175

Phone: +61 3 5792 2388

Email: info@scandiastoves.com.au