

ASSEMBLY INSTRUCTIONS FOR EXECUTIVE SERIES

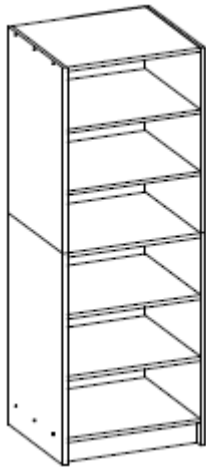

EXEC-SHELF

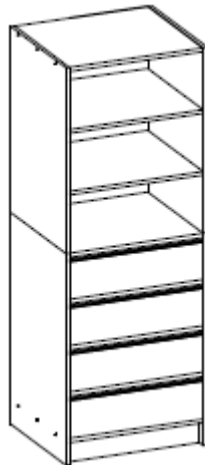

EXEC-4J

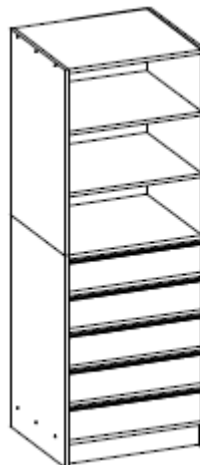

EXEC-5C

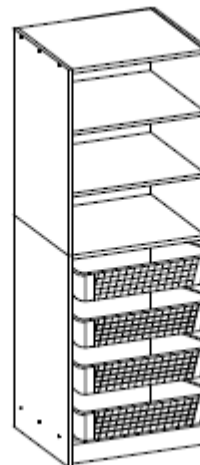

EXEC-4B

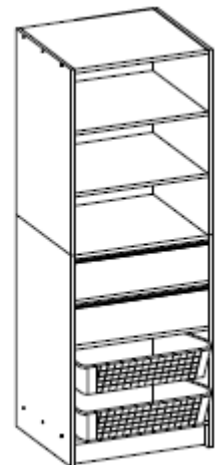

EXEC-2B

Side Gables " BOTTOM SECTION " **A** & **E** = 1035 X 445 X 16

Side Gables " TOP SECTION " **G** & **I** = 965 X 445 X 16

TOP, BOTTOM & MIDDLE FIXED SHELVES.

1 X TOP **H** = 575 X 443 X 16

1 X MIDDLE **D** = 575 X 443 X 16

1 X BOTTOM **C** = 575 X 443 X 16

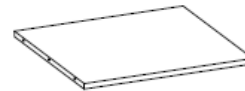

ADJUSTABLE SHELVES **K** - 2 X 575 X 443 X 16







KICK BOARD **B** - 1 X 575 X 61 X 16

BACK PANELS - 1 X TOP **J** = 973 X 605 X 3mm

1 X BOTTOM **F** = 963 X 605 X 3mm

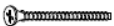

HARDWARE LIST

NO.	MODEL	DESCRIPTION	QTY
1.		M50 X 5mm CONFIRMAT SCREWS	20
2.		WHITE COVER CAPS	20
3.		BACKING NAILS	75
4.		SHELF SUPPORT PINS	16
5.		DOWELS	4

ASSEMBLY INSTRUCTIONS FOR EXECUTIVE SERIES (BOTTOM SECTION)

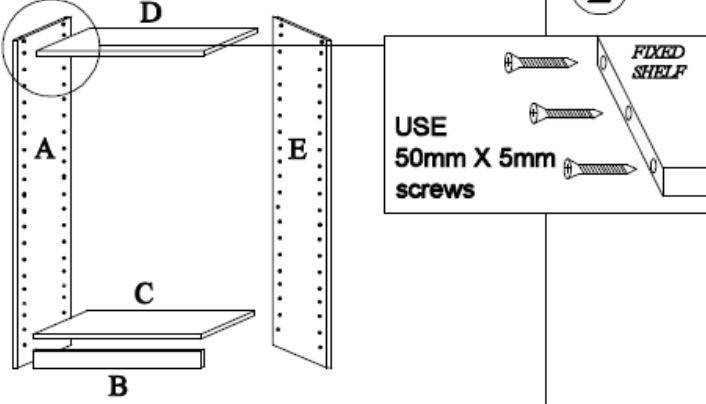
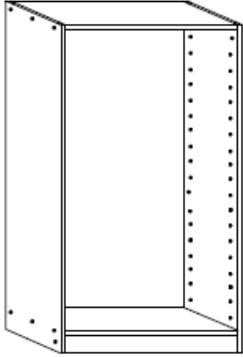
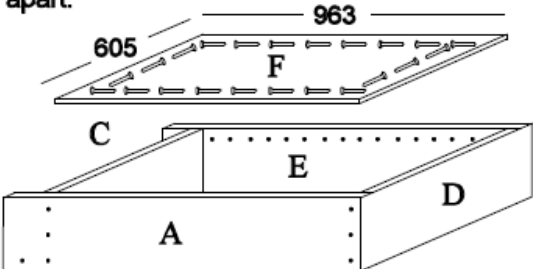
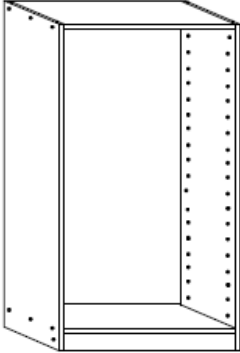
<p>1</p>  <p>USE 50mm X 5mm screws</p>	<p>2</p> 
<p>3</p> <p>Fixing of the Backing Panel F 963 x 605</p> <p>1. Place unit face down on the floor.</p> <p>IMPORTANT</p> <p>2. To ensure that the side gables A & E remain straight, start by placing the back panel F flush with the bottom of fixed shelf C keeping in the centre of side gables A & E nail (tack) at each side. Then keeping the back PARALLEL to the side gables nail (tack) the middle of each side, then the top, check measure the top middle and bottom are the same measurement, adjust if necessary! If ok, continue by placing nails approx 100mm apart.</p>  <p><i>Back View</i></p>	<p>4</p>  <p><i>Bottom Section Complete</i></p>

ASSEMBLY INSTRUCTIONS FOR EXECUTIVE SERIES (TOP SECTION)

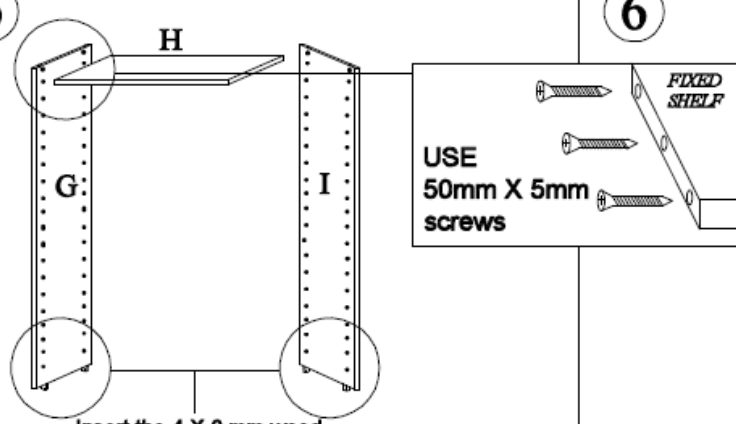
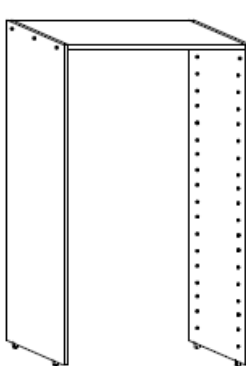
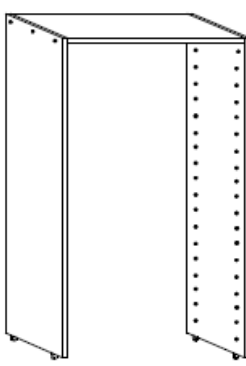
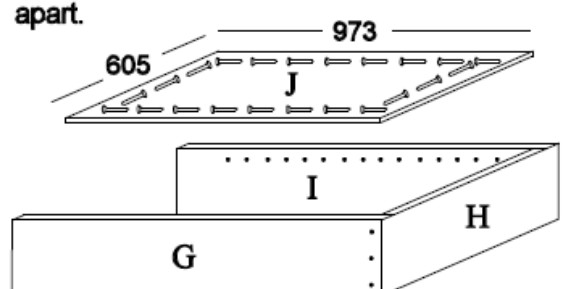
<p>5</p>  <p>Insert the 4 X 8 mm wood dowels with wood glue.</p>	<p>6</p> 
<p>7</p> <p>Fixing of the Backing Panel J 973 x 605</p> <p>1. Place unit face down on the floor.</p> <p>IMPORTANT</p> <p>2. To ensure that the side gables G & I remain straight, start by placing the back panel J flush with the top of fixed shelf H keeping in the centre of side gables G & I nail (tack) at each side. Then keeping the back PARALLEL to the side gables nail (tack) the middle of each side, then the top, check measure the top middle and bottom are the same measurement, adjust if necessary! If ok, continue by placing nails approx 100mm apart.</p>	<p>8</p>  <p><i>Top Section Complete</i></p>
 <p><i>Back View</i></p>	

ASSEMBLY INSTRUCTIONS FOR EXECUTIVE SERIES (JOINING TOP & BOTTOM SECTIONS TOGETHER)

9

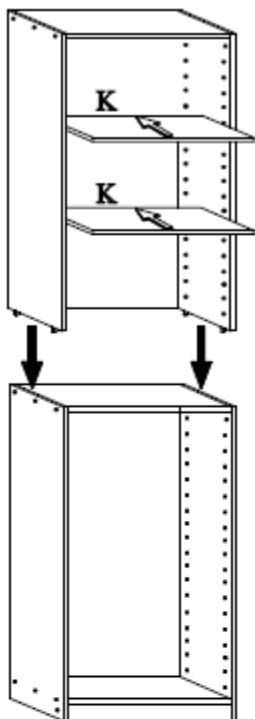

1. Place the top section over the bottom section aligning the 4 x dowels with the 8 mm holes, add some wood glue & push down firmly. Complete the nailing of the backs to shelf D. While standing in the upright position.

11

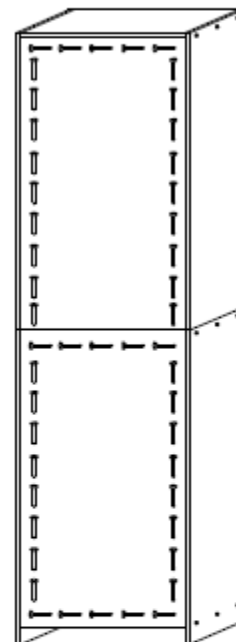

BACK VIEW

10

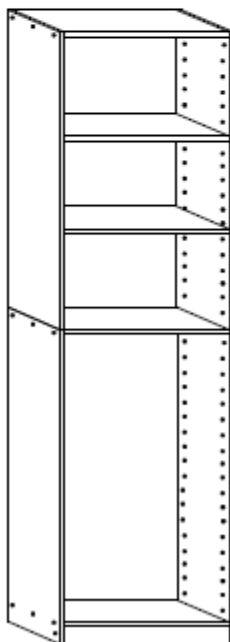

COMPLETED

IMPORTANT

* FOR THE ASSEMBLY & PLACEMENT OF DRAWERS & BASKETS PLEASE REFER TO INSTRUCTIONS ENCLOSED IN THE CARTON MARKED- PART 2