



HERITAGE RANGE TIERED PLANTER

1300mm (L) 800mm (W) 850mm (H)

IMPORTANT

This heritage timber bed is manufactured from the highest quality cypress heartwood. To prevent discolouration over time it is recommended that once assembled the external surfaces are coated with a quality natural oil or stain. Repeat every 6-12 months.

Before filling the bed with soil, ensure it is square and level.

Be aware that this timber product may splinter so it is recommended that protective gloves are worn during assembly.

KIT CONTENTS

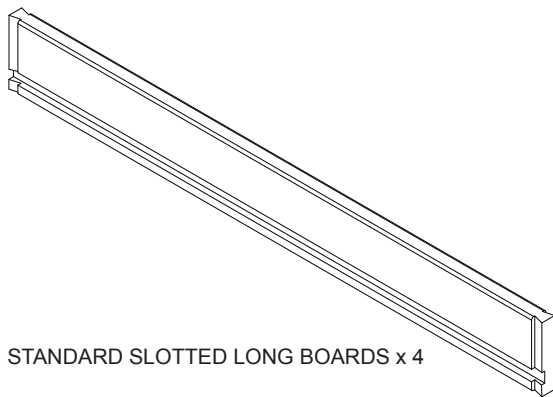

STANDARD SLOTTED LONG BOARDS x 4

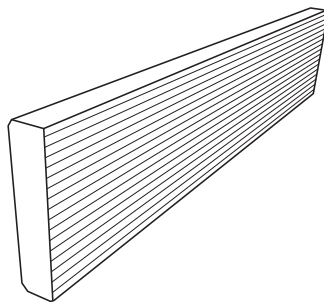

STANDARD BASE BOARDS x 12

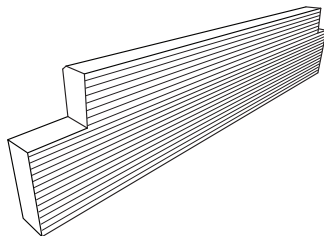

NOTCHED BASE BOARDS x 4

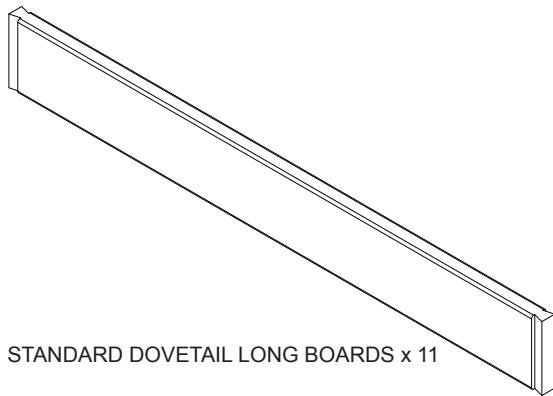

STANDARD DOVETAIL LONG BOARDS x 11

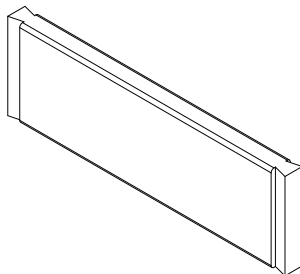

STANDARD DOVETAIL SHORT BOARDS x 18

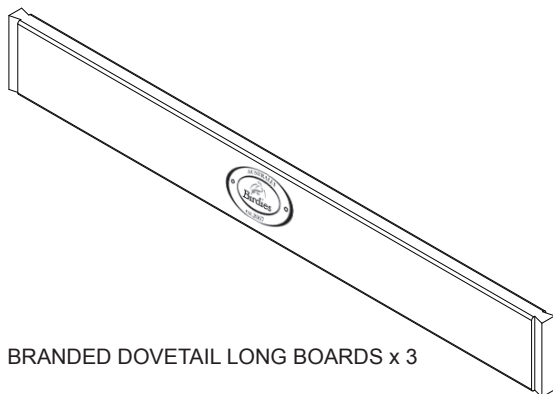

BRANDED DOVETAIL LONG BOARDS x 3

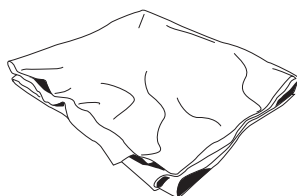

GEOTEXTILE FABRIC x 3

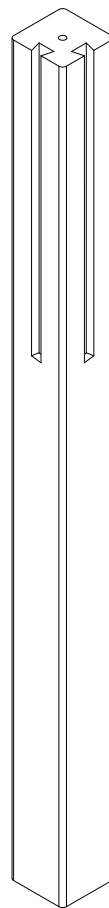

1 DOVETAIL POSTS x 2

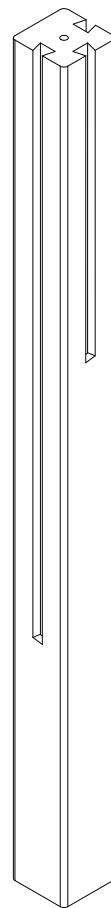

2 DOVETAIL POSTS x 2

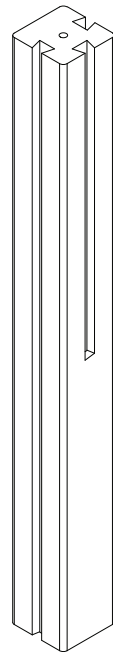

3 DOVETAIL POSTS x 2

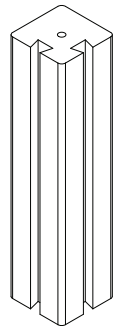

4 DOVETAIL POSTS x 2



HARDWOOD DOWELS x 8

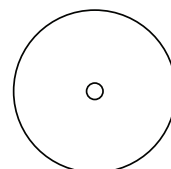

STAINLESS STEEL SUPPORT DISCS x 4

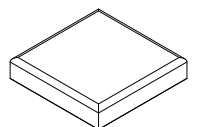

CAPS x 8

ASSEMBLY

STAGE 01

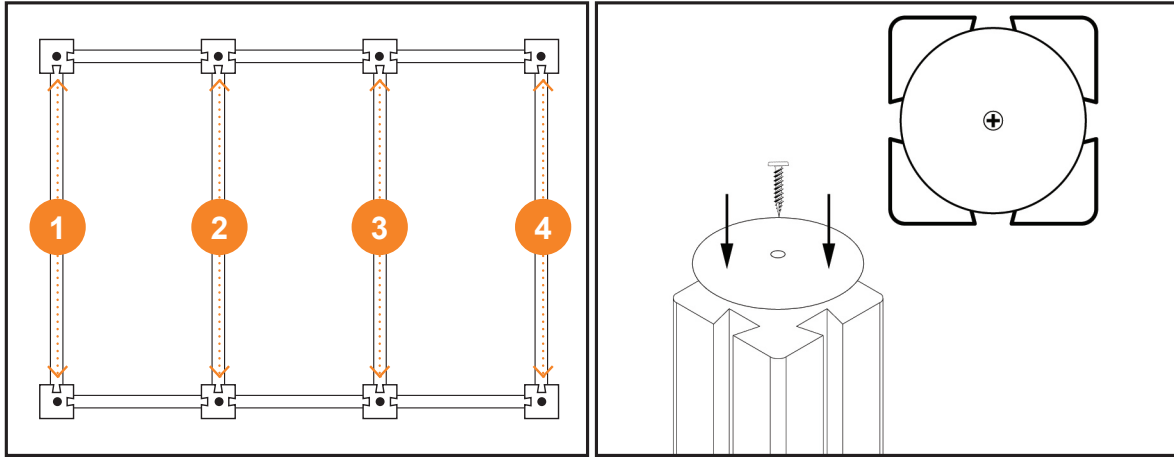

Ensure the 8mm hole is to the top of all posts. Refer to the above Kit Contents diagram for post location numbers.

Posts 3 and 4 will require the discs if the Tiered planter is not on a hard level surface such as concrete, deck or pavers. Screw the disc to the bottom of the post as shown. Note the larger 8mm hole is the top of the post.

STAGE 02

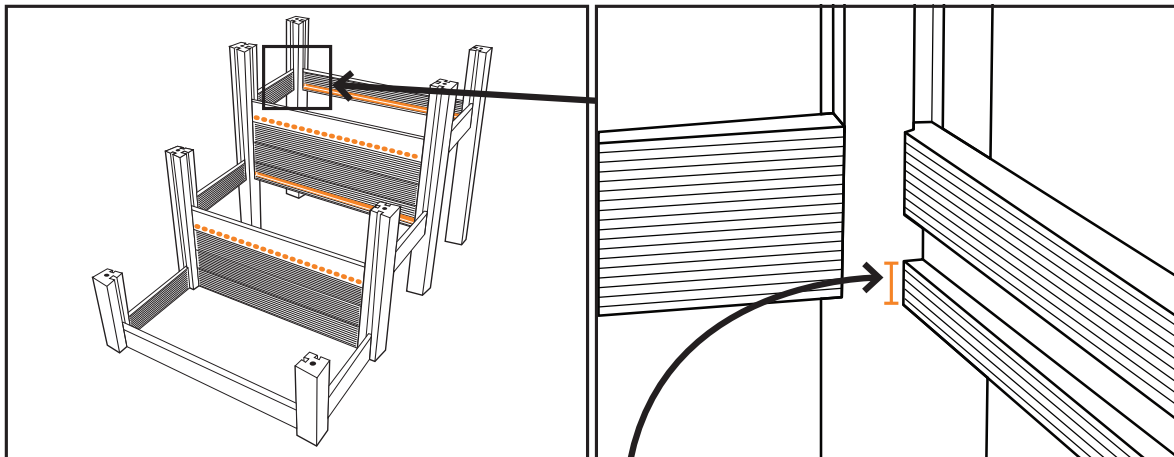

Initially place in all boards as shown above with the grooved (reeded) side of the boards facing inwards. Apply equal force downwards to slide the boards in. The orange dashed lines represent the slot on the reverse side of the board.
(IMPORTANT - SEE DETAIL)

● The slotted long board must go in with the **SMALLER** section of reeded timber **UNDER** the slot.

STAGE 03

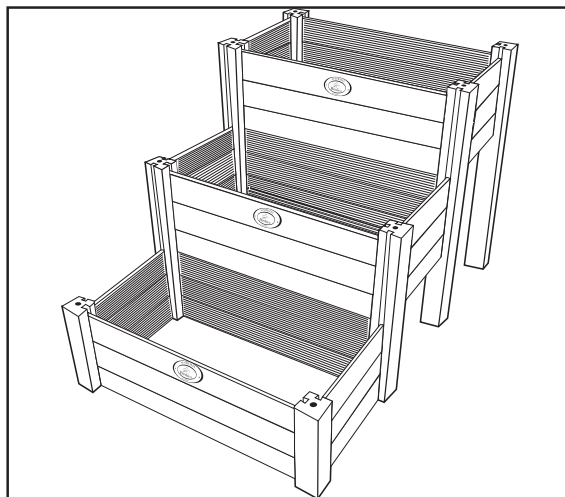

Slide in the remaining boards ensuring the Birdies branded long boards are located in the top row.

STAGE 04

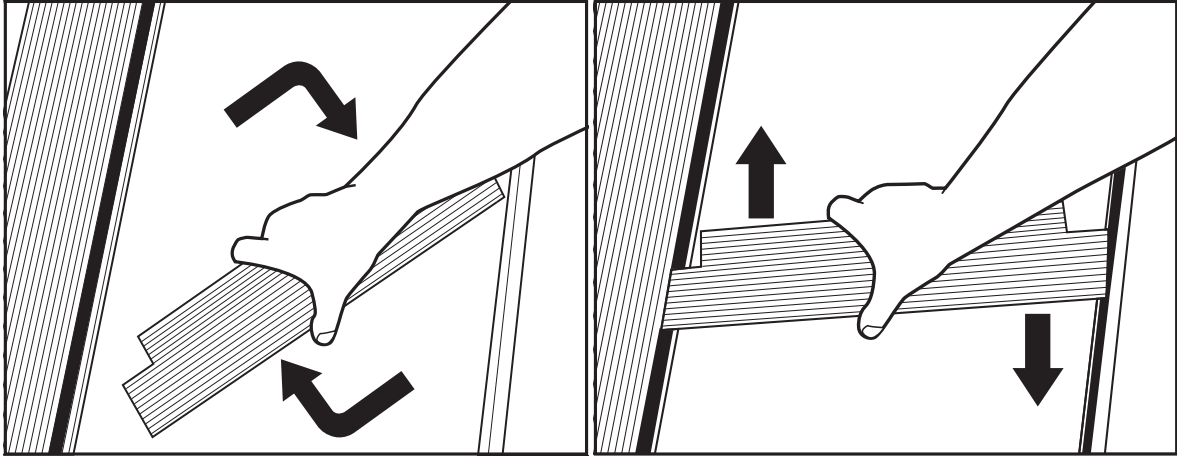

Insert each left and right notched board by laying in the slot and turning the boards clockwise

STAGE 05

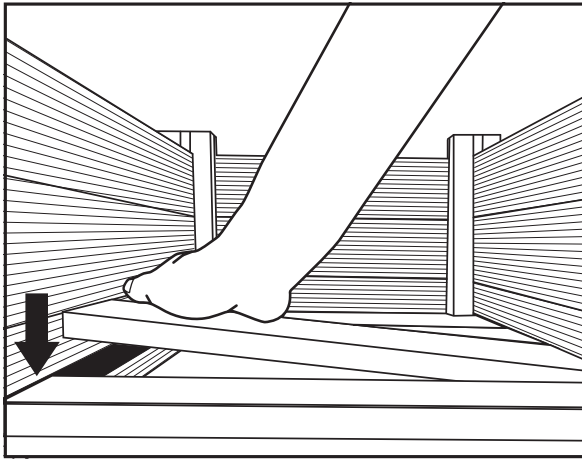

Turn the remaining base boards into the slotted long board. The final two base boards will need to be installed by laying one side of the board into the slot, then pushing the other side down until it is locked in.

STAGE 06

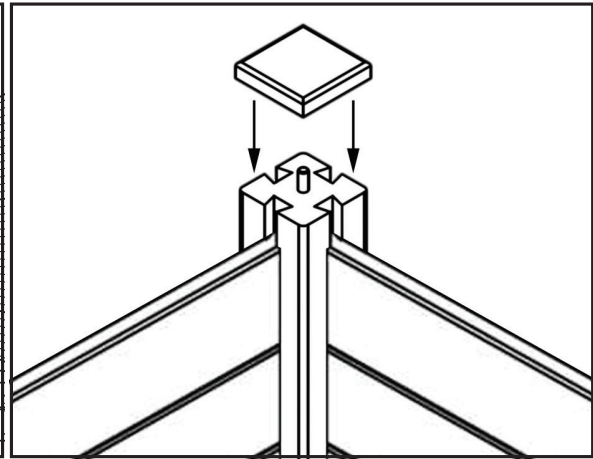

Insert the 4 hardwood dowels into the holes on the top of the posts by hand and then place 4 caps over these dowels. Push down to secure.

OPTIONAL

Wood glue can be used to fix the cap in place.

STAGE 07

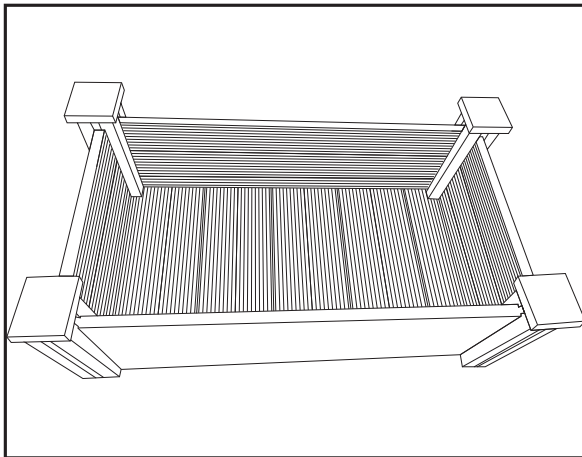

Spread the base boards evenly, leaving approximately 10mm between each base board.

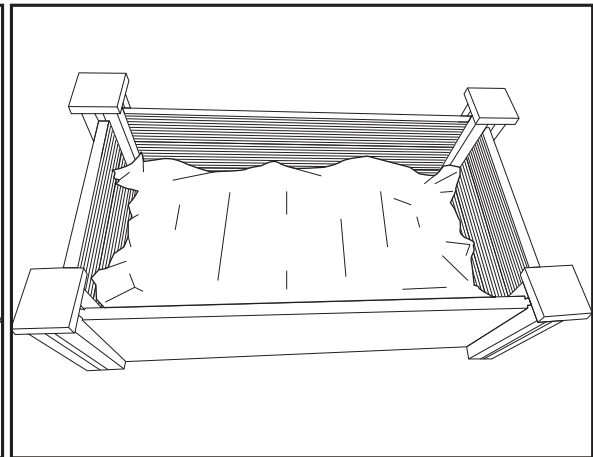

Lay the black geotextile fabric in evenly. Allow excess fabric to lay up the walls. Start filling by placing the soil into each corner of the planter whilst holding the fabric up, this will prevent soil from washing away once filled.