

# GardenShed

1.5W x 0.8D x 2.0Hm



1.5m Skillion Series

Assembly instructions

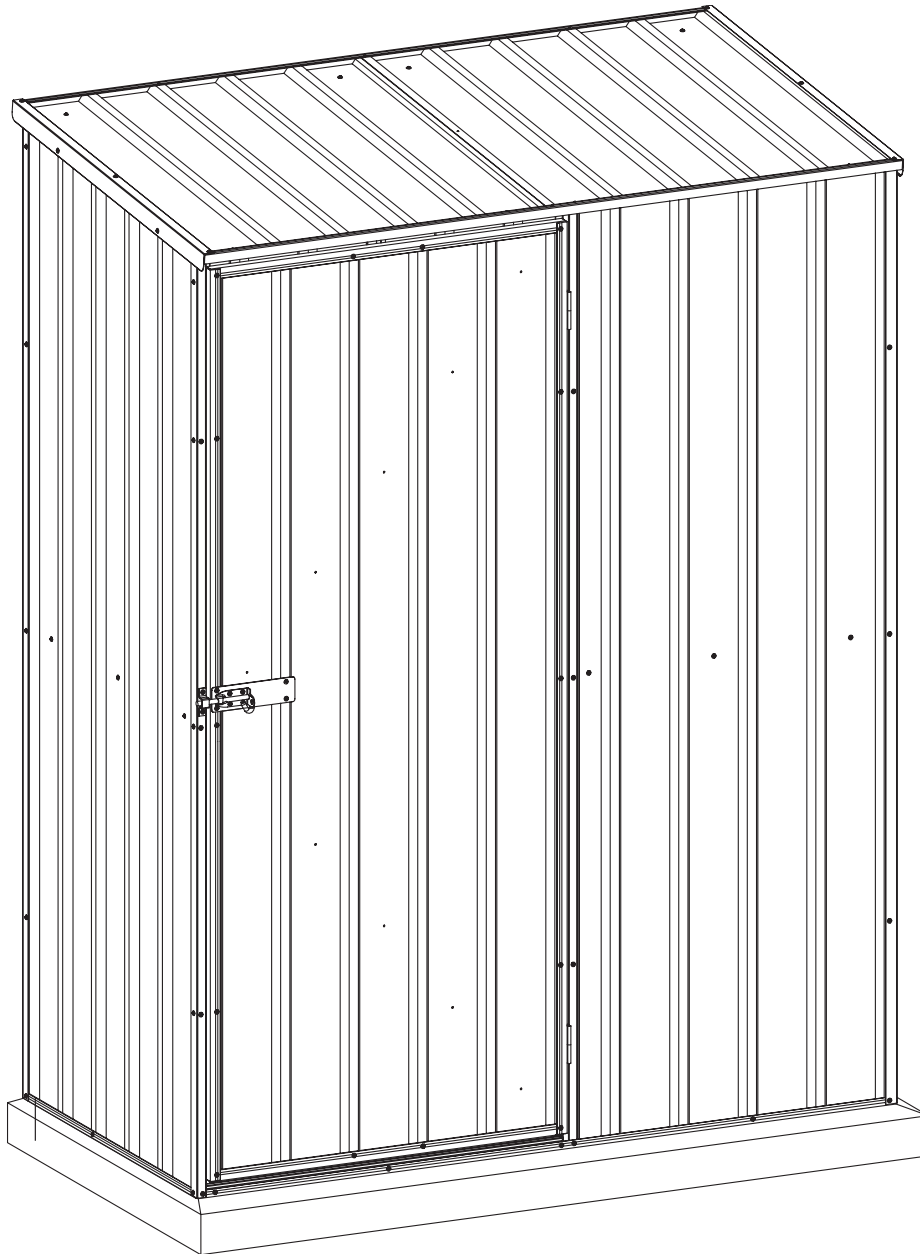

**Congratulations** on purchasing your new Pinnacle garden shed. Before assembling, we recommend you read the instructions thoroughly. Your new shed comes with pre-drilled holes to make assembly quicker. We recommend you assemble the shed using a trestle table or sawhorses and planks. This will ensure that you are working off the ground and make it easier for you. Assembly is a two-person job and should not be attempted in windy conditions.

## SAFETY TIP:

When assembling or installing this product wear protective gloves and eyewear.

**Tools required:** Drill, measuring tape, phillips-head screw driver, rivet gun, rubber mallet, sturdy ladder, shifting spanner, 2 saw horses, 3mm steel drill bit, 4mm steel drill bit and a 9mm masonry drill bit.

# GardenShed 1.5 x 0.8 x 2.0m

## Build your garden shed in 7 easy steps!

- Step 1:** Check all parts against the component list
- Step 2:** Assemble the rear wall panels
- Step 3:** Assemble the side wall panels
- Step 4:** Assemble the roof panels
- Step 5:** Assemble the front wall panel
- Step 6:** Assemble the front door
- Step 7:** Fit the panels together





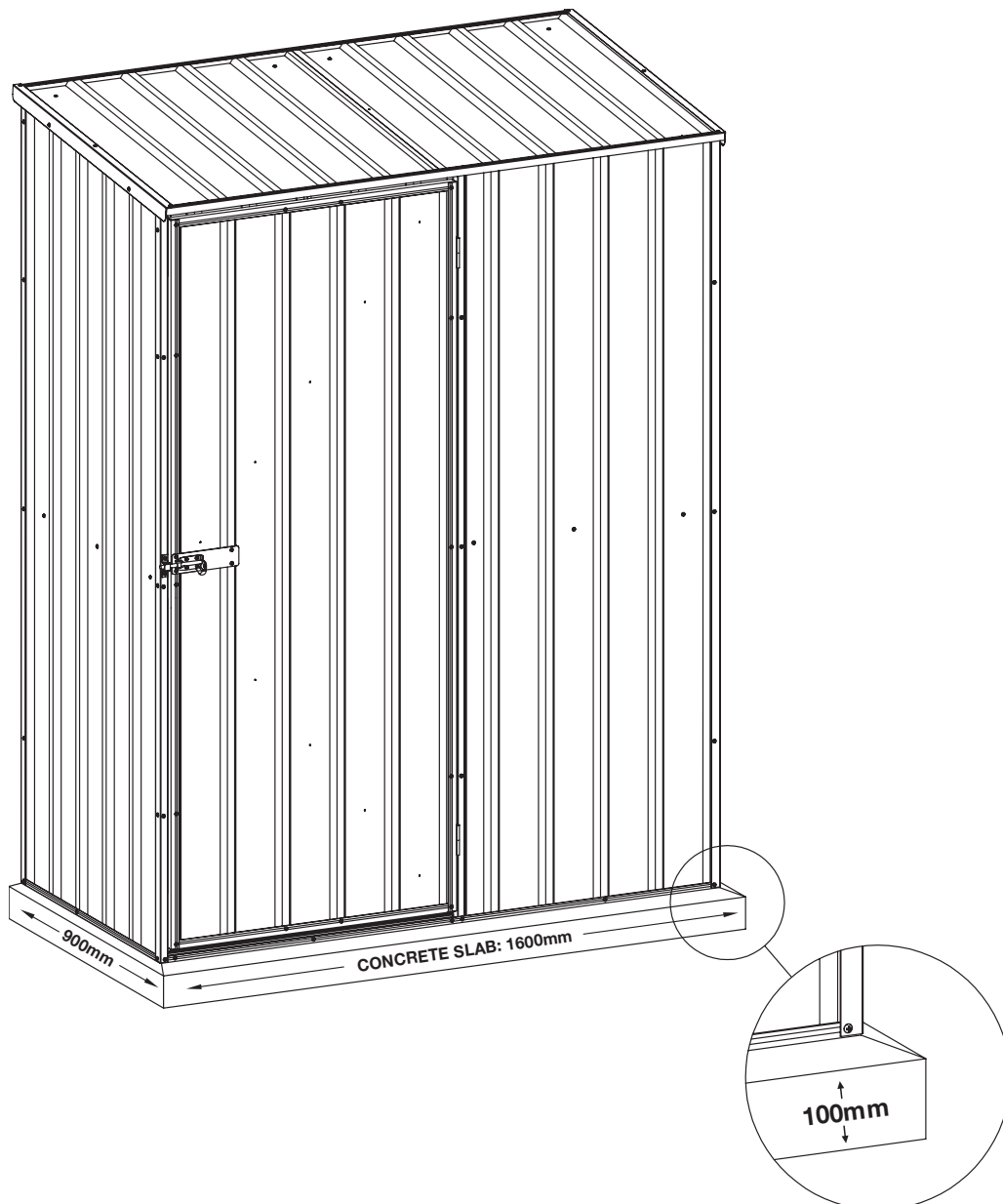

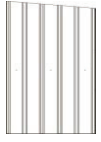
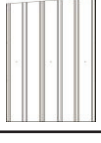

**IMPORTANT:** *It is recommended that your new shed is secured to a concrete slab as per the specifications in this manual.*

**Concrete slab:** Please ensure that your site is level. It is recommended that your slab is 100mm thick and you use builder's plastic and F52 reinforcing mesh. We recommend that you make your slab approximately 100mm bigger than the base dimensions of your shed. This will allow for a 50mm edge around your shed. We recommend that you slope the 50mm edges downward by 10mm so that rain water can drain away from your shed.

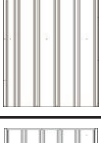
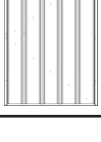

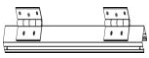

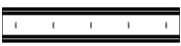







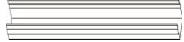

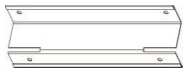

**Step 1:** Check all parts against the component list

Lay out all parts with number facing outwards and check off against parts list.





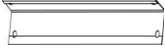



Picture	Description	Component	Location	Part No.	QTY	Check
	Sheet	Sheet 1980x770	Rear wall	1B	2	
	Sheet	Sheet 1900-1980x770 (Left)	Side wall	2B	1	
	Sheet	Sheet 1900-1980x770 (Right)	Side wall	2C	1	
	Sheet	Sheet 855x770	Roof	3	2	
	Sheet	Sheet 1900x708	Front	4B	1	
	Door Sheet	Sheet 1845x770	Door	5B	1	
	Channel	Channel 1843	Door	24F	1	
	Channel	Channel 1843	Door	24G	1	
	Channel	Channel 768	Door	M26	2	
	Brace	Brace 1034	Door	U12	2	
	Channel	Channel 1508	Roof	20A	2	
	Channel	Channel 1508	Rear wall	20B	1	

# GardenShed 1.5 x 0.8 x 2.0m

Picture	Description	Component	Location	Part No.	QTY	Check
	Channel	Channel 1508	Rear wall	20C	1	
	Channel	Channel 1508	Front	20D	1	
	Channel	Channel 1508	Front	20E	1	
	Channel	Channel 768	Side wall	21A	2	
	Channel	Channel 768	Side wall	21B	2	
	Channel	Channel 775	Front	23	1	
	Channel	Channel 1458	Rear wall	31	1	
	Channel	Channel 718	Side wall	32	2	
	Channel	Channel 674	Front	33R	1	
	Jamb	Jamb 1898	Front	41A	1	
	Jamb	Jamb 1898	Front	41B	1	
	Jamb	Jamb 775	Front	42	1	
	Brace	Corner brace	Corner	Z17	1	

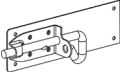
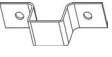
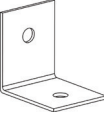
Picture	Description	Component	Location	Part No.	QTY	Check
	Brace	Corner brace	Corner	Z18	1	
	Brace	Corner brace	Corner	Z19	1	
	Brace	Corner brace	Corner	Z20	1	
	Lip	Lip 856	Roof	50	2	
	Brace	Joining brace	Door	W	1	

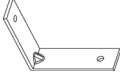
**Fittings part list:**

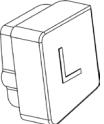
Picture	Component	QTY	Picture	Component	QTY	
	Self-tapping screws (10mm)	130		Self-tapping screws (16mm)	20	
	4 x 10mm Rivet	12		3 x 10mm Rivet	40	
	Pad bolt (part: 70)	1		Keeper (part: 71)	1	
	Bracket	8		5/16 x 19mm Hexagonal bolt	8	
	5/16 Hexagonal Nut	8		Mid wall brace bracket (part:72)	3	
	Self tapper safety cover	25		Channel safety cover (L type)	1	

# GardenShed 1.5 x 0.8 x 2.0m

Picture	Component	QTY	Picture	Component	QTY
	Channel safety cover (R type)	1		Plastic stopper	4
	Sleeve anchor bolt	8			

Qty checking date: \_\_\_ / \_\_\_ / \_\_\_

Qty checking personal badge number: \_\_\_\_\_

Signature: \_\_\_\_\_

In the unlikely event that you find you are missing a part, please contact Pinnacle at 1800 349 776. A copy of proof of purchase may be requested.

## Shed overview:

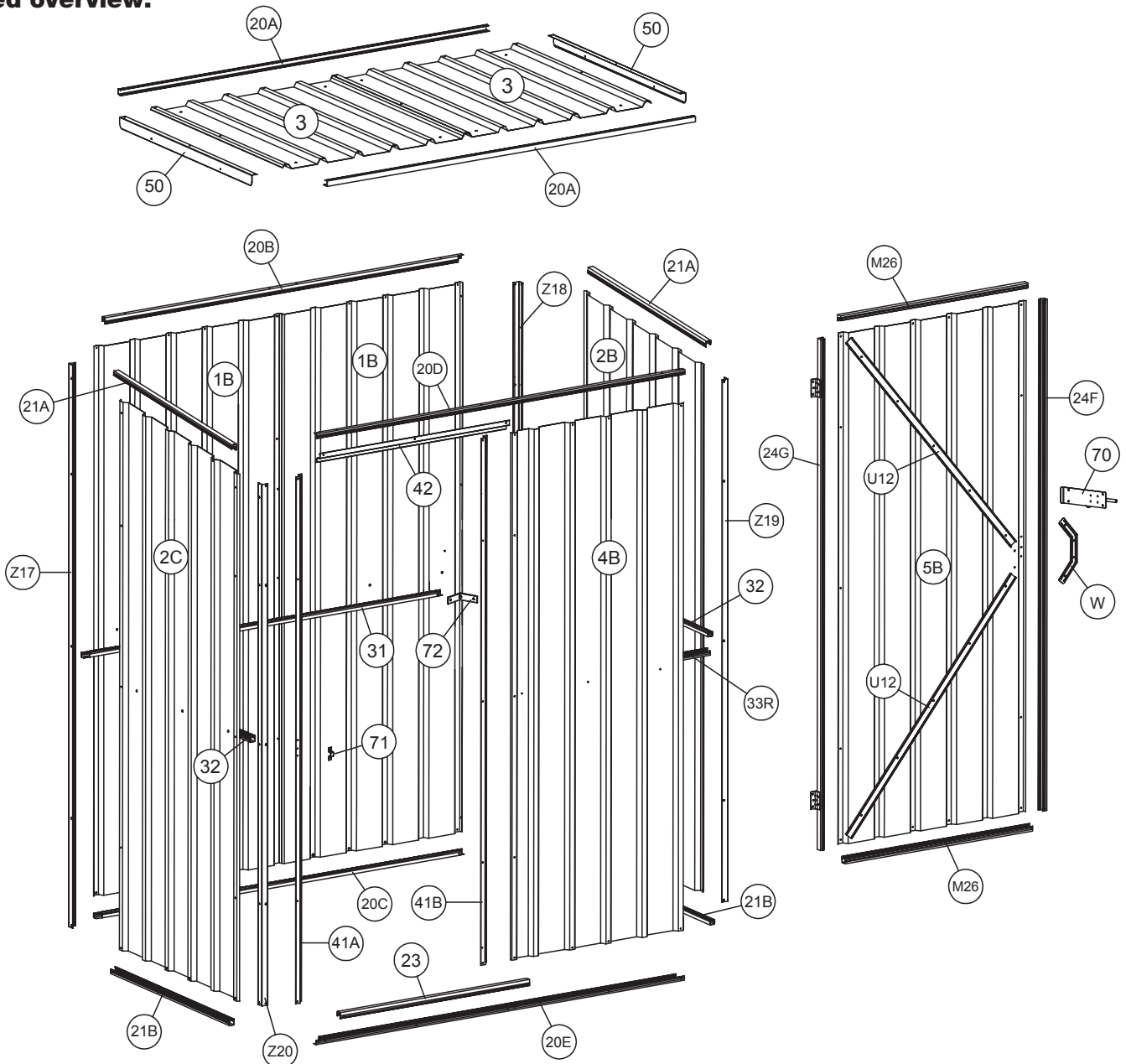

**Step 2:** Assemble the rear wall panels

You will find it easier to assemble your shed using sawhorses with timber studs attached (timber needs to be the same length as the shed (1.5m)) or alternatively, a trestle table.

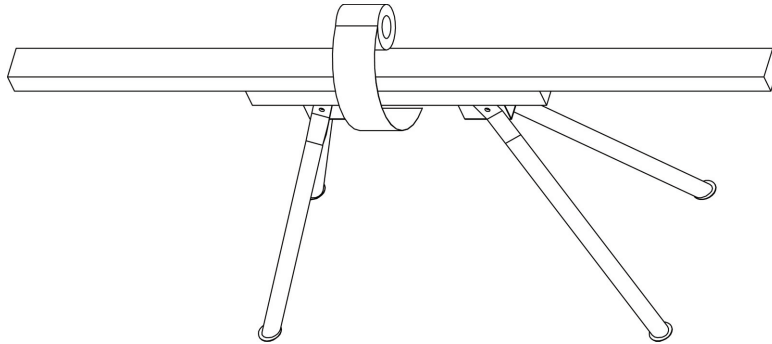

Place 2 x part 1B (Sheet) on your worktable and join them together with the self-tapping screws as per diagram below.

Now fit part 20B (top channel) and 20C (bottom channel) to the sheeting by tapping it in (diagram A) or sliding it in (diagram B). Make sure that the small lip of the channel is always facing out. This ensures rain water cannot build up inside your shed.

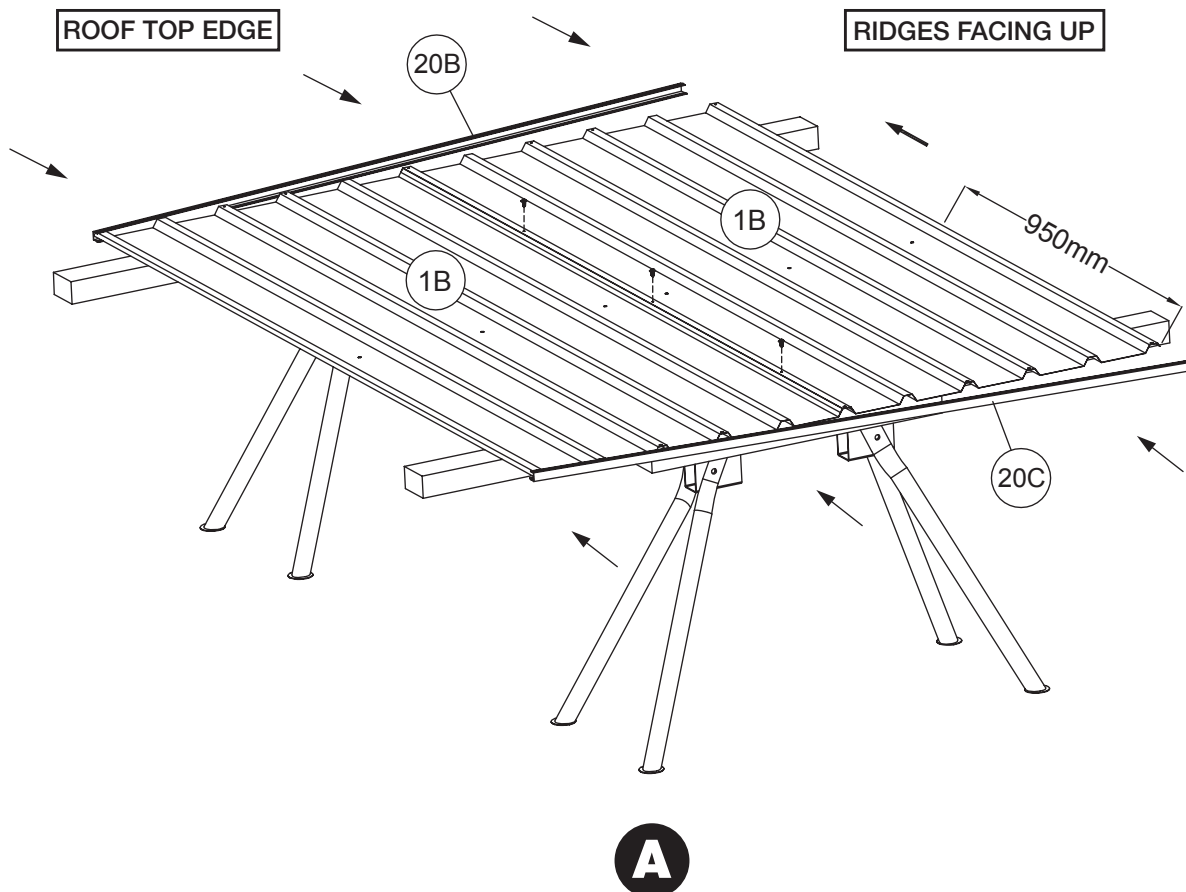

# GardenShed 1.5 x 0.8 x 2.0m

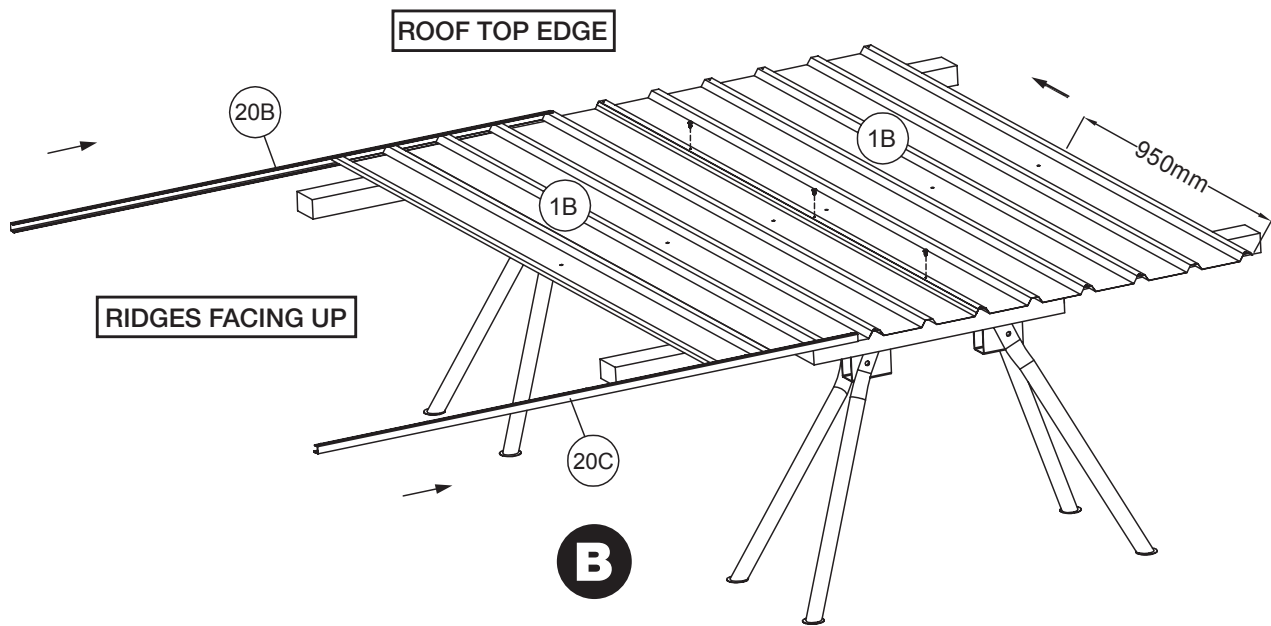

## Step 2: Assemble the rear wall panels (continued)

Now fit part 31 (mid wall channel) to the sheeting and position it with the provided self-tapping screws. Please note the groove should face downwards. Position the top and bottom channels with self-tapping screws as well. **NOTE:** All screws marked with a cross should not be fixed at this stage.

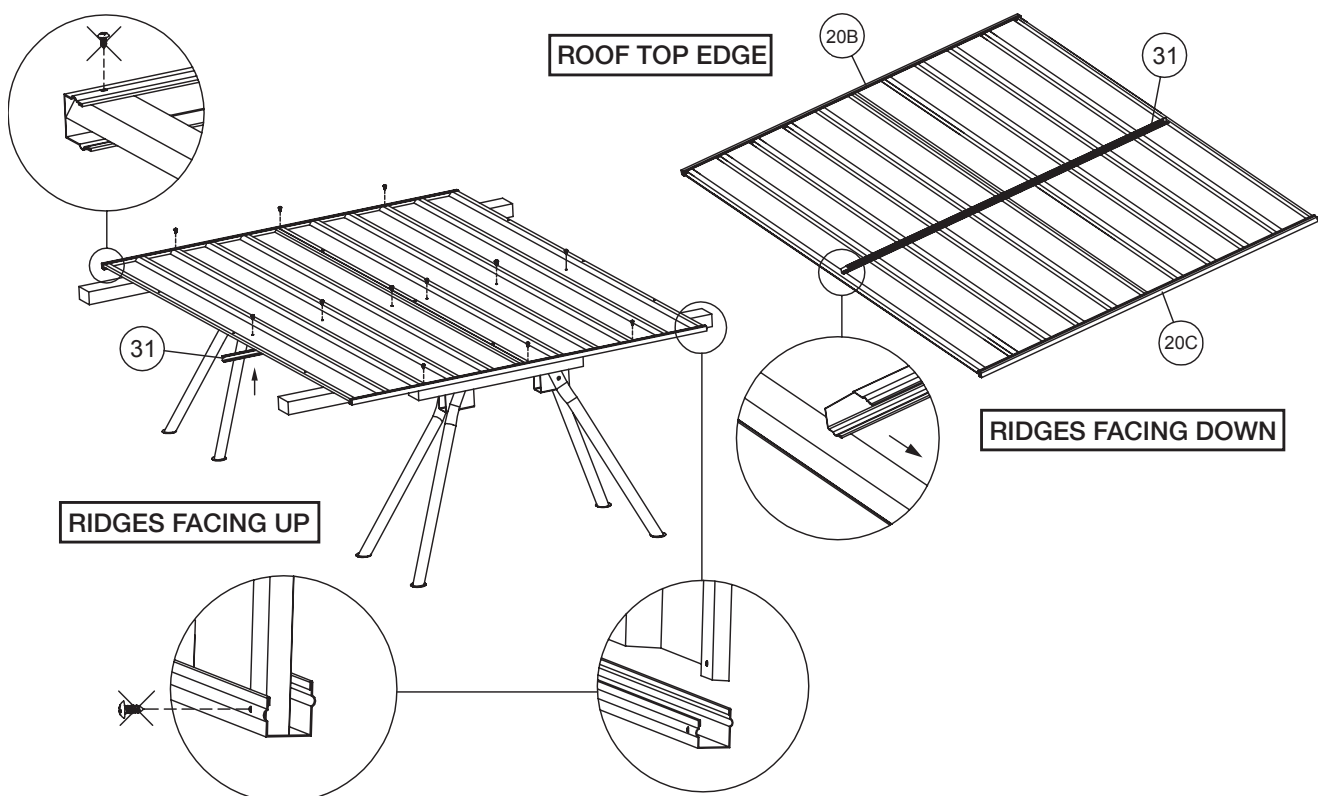



**Step 3:** Assemble the side wall panels

Place part 2B (sheet) on your worktable and tap or slide in part 21A (top channel) and part 21B (bottom channel). Position and fix part 32 (mid wall channel) using the self-tapping screws ensuring this channel is facing down before fixing. Fix part 21B (bottom channel) with self-tapping screws but not part 21A (top channel) at this stage. Make sure the small lip of the channels is always facing out. This ensures rain water cannot build up inside your shed. Repeat the same steps for part 2C (the other sidewall). **NOTE:** All screws marked with a cross should not be fixed at this stage.

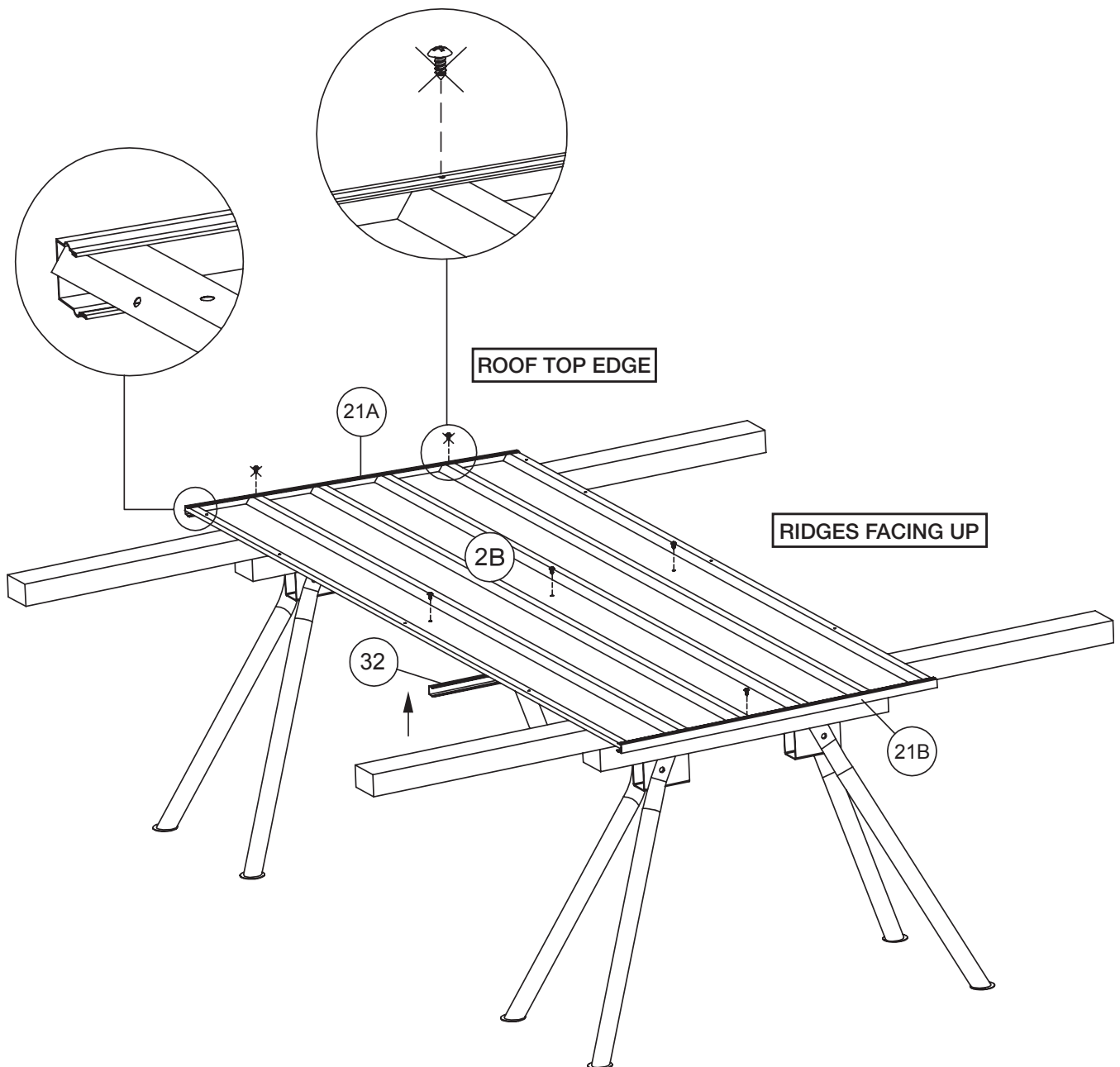

# GardenShed 1.5 x 0.8 x 2.0m

## Step 4: Assemble the roof panel

Place 2 x part 3 (sheet) on your worktable and join together with the self-tapping screws as per the diagram below.

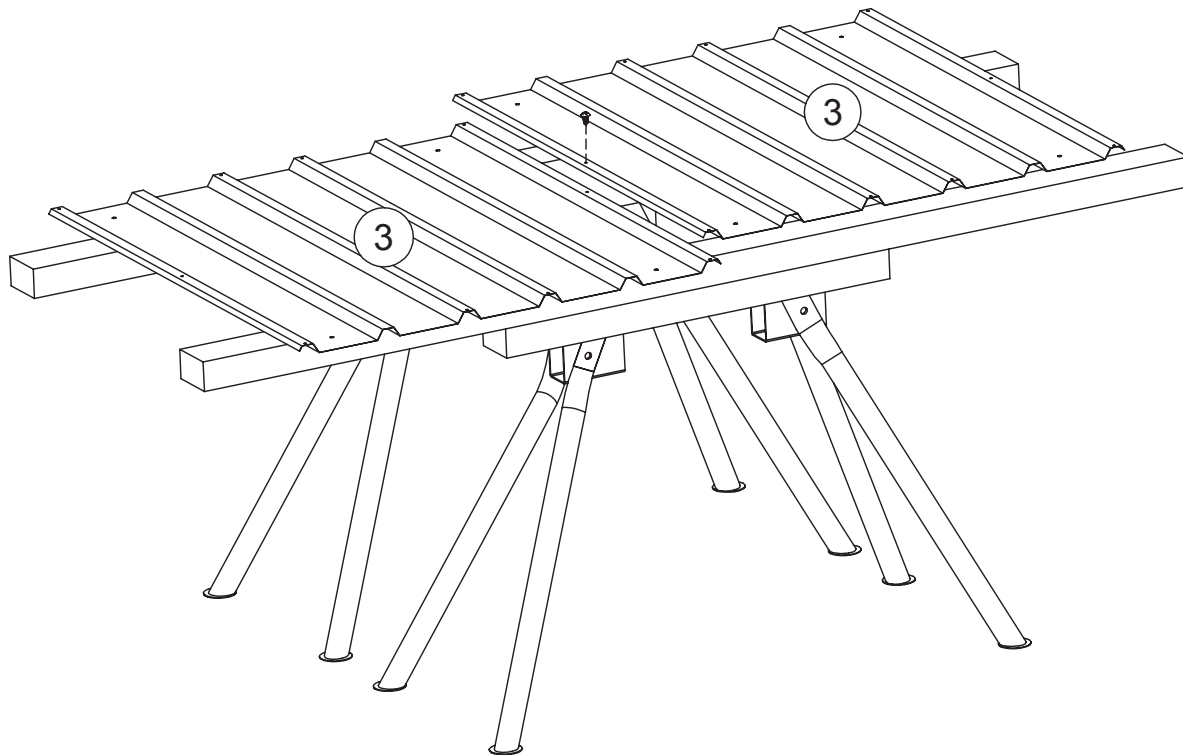

Now tap or slide 2 x part 20A (channels) onto the sheeting and fix them to the top and bottom with self-tapping screws. Make sure that the small lips on channels 20A are always facing out. This ensures rainwater cannot build up inside your shed.

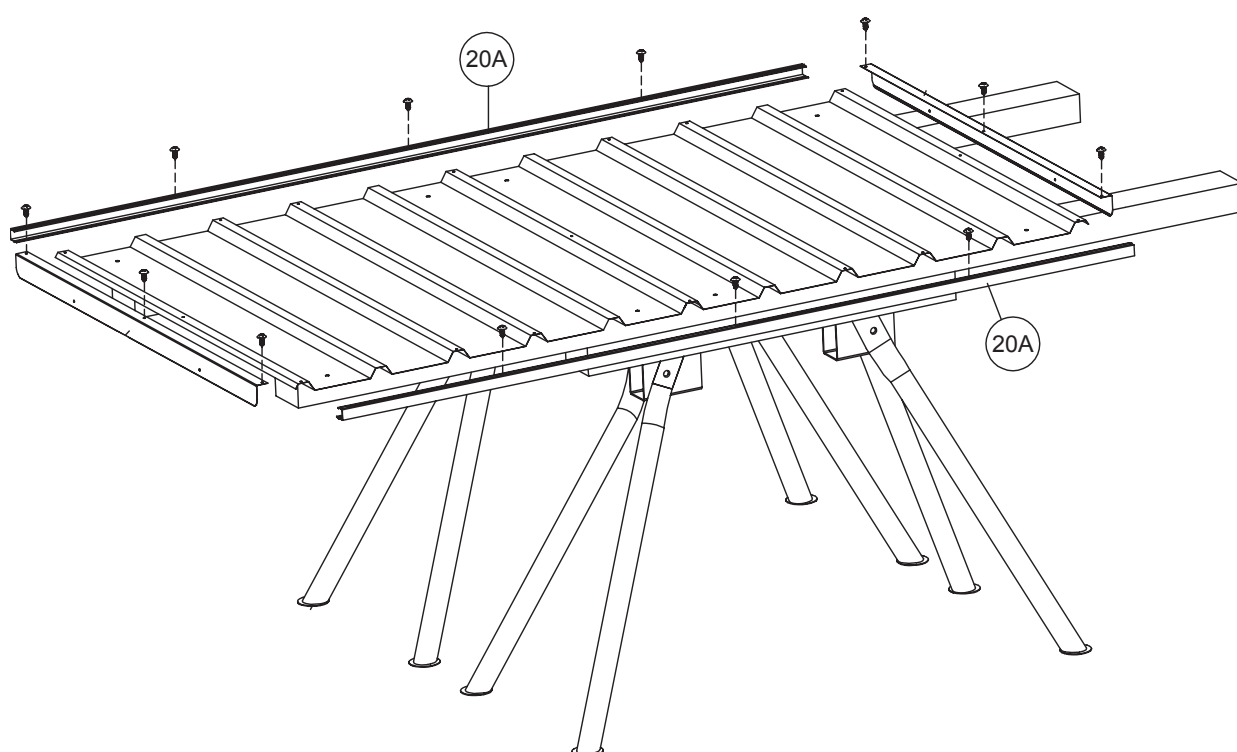

**Step 4:** Assemble the roof panel (continued)

Now fit 2 x part 50 (side lips) to the sheeting and fix them with self-tapping screws.

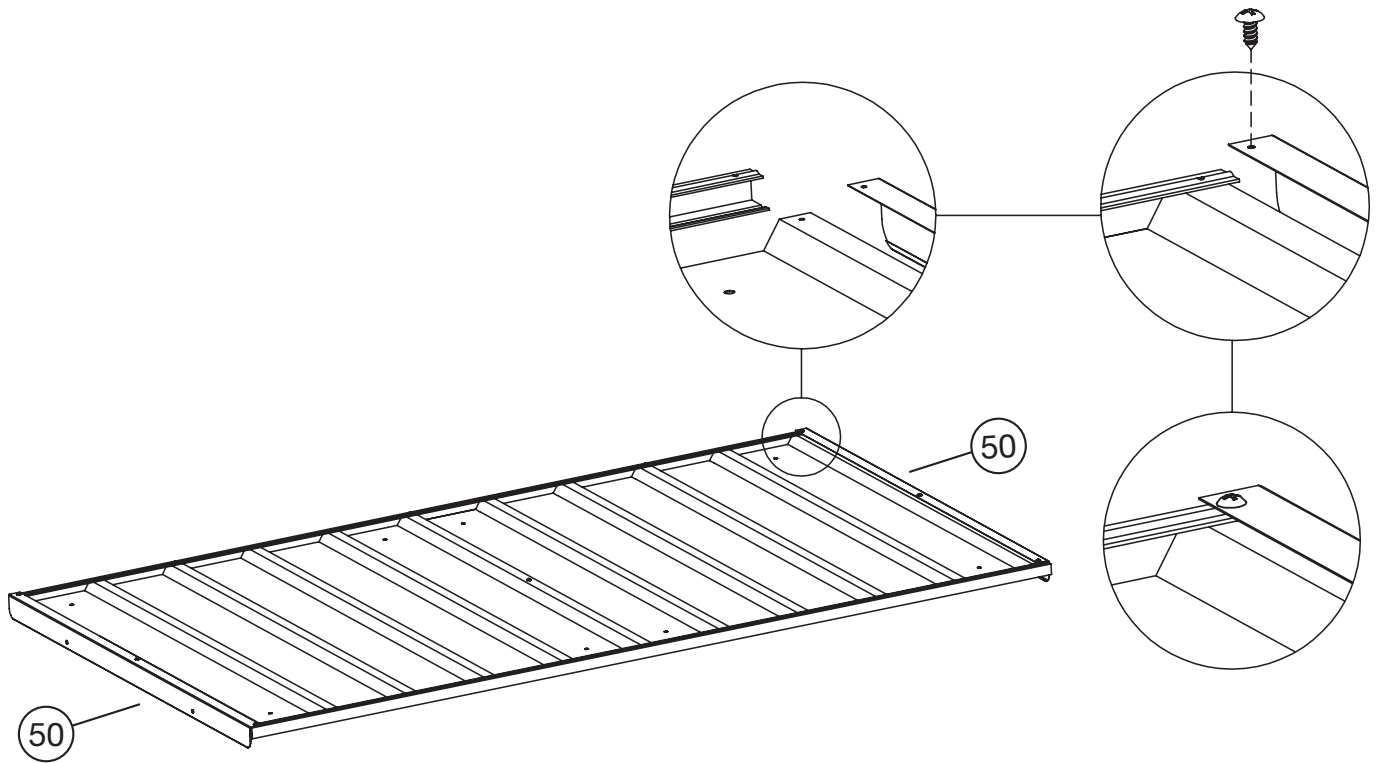

# GardenShed 1.5 x 0.8 x 2.0m

## Step 5: Assemble the front wall panels

Place part 4B (sheet) on the worktable. Fit part 20D (top channel), part 20E (bottom channel), part 41B (jamb) (There are pre-drilled holes for the next step on both parts 4B and 41B that must be aligned) and part 33R (mid wall channel) to the sheeting and fix them with self-tapping screws - except those marked with a cross. **Note:** Groove on mid-wall channel should be facing down when fixed. Make sure that the small lips on channels 20D and 20E are always facing out. This ensures rainwater cannot build up inside your shed.

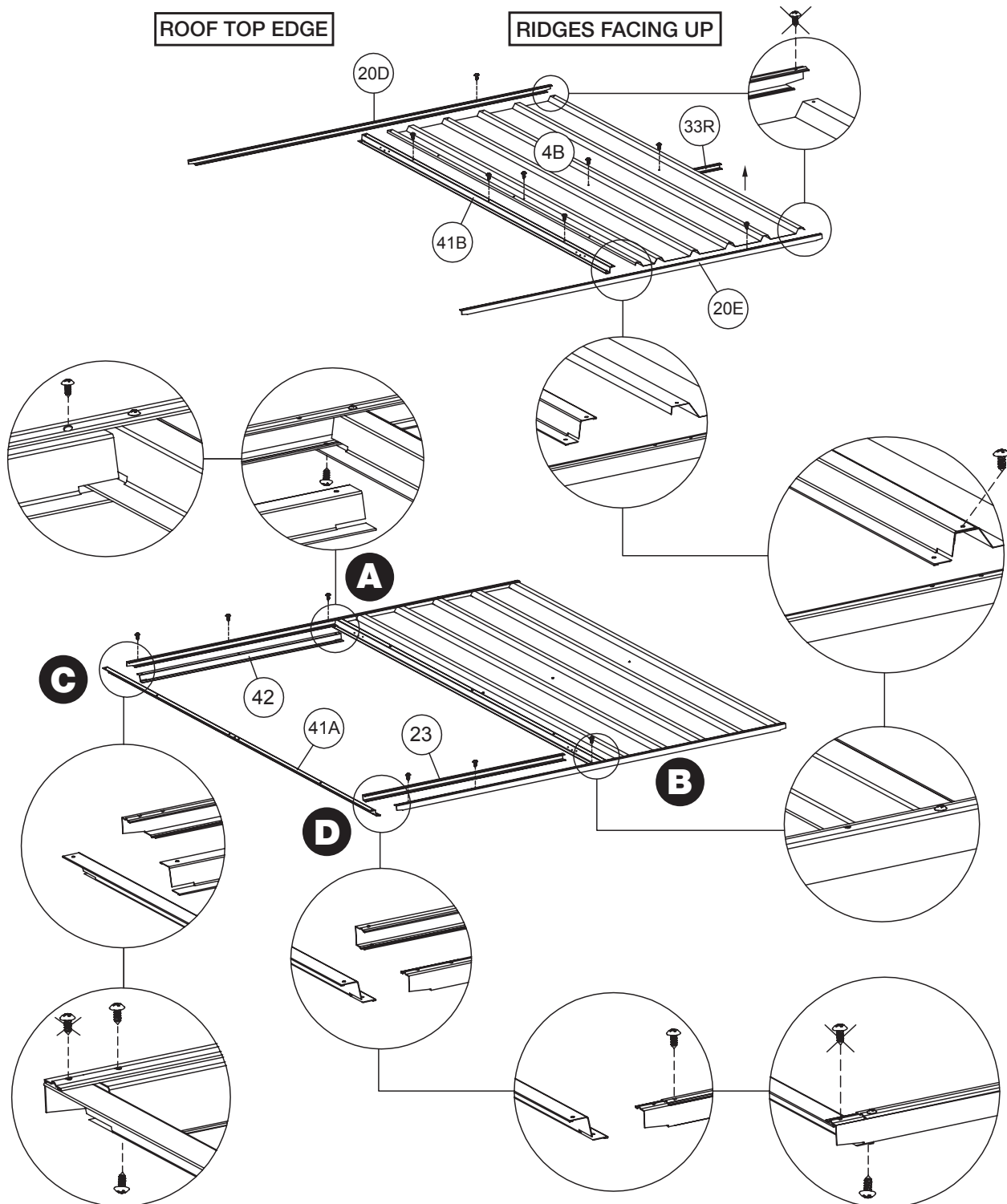

Fit part 41A (jamb), part 42 (jamb) and part 23 (bottom channel) and fix them with self-tapping screws - except those marked with a cross. Make sure both joins (diagrams A and B) are fixed the same followed by diagrams C and D.

**Step 6:** Assemble the front door

Place part 5B (door sheet) on the worktable. Fit 2 x part M26, part 24G and part 24F (channels) to the door with the provided 3.0 x 10mm rivets. Make sure that the small lips on channels M26 are always facing out. This ensures rainwater cannot build up inside your shed.

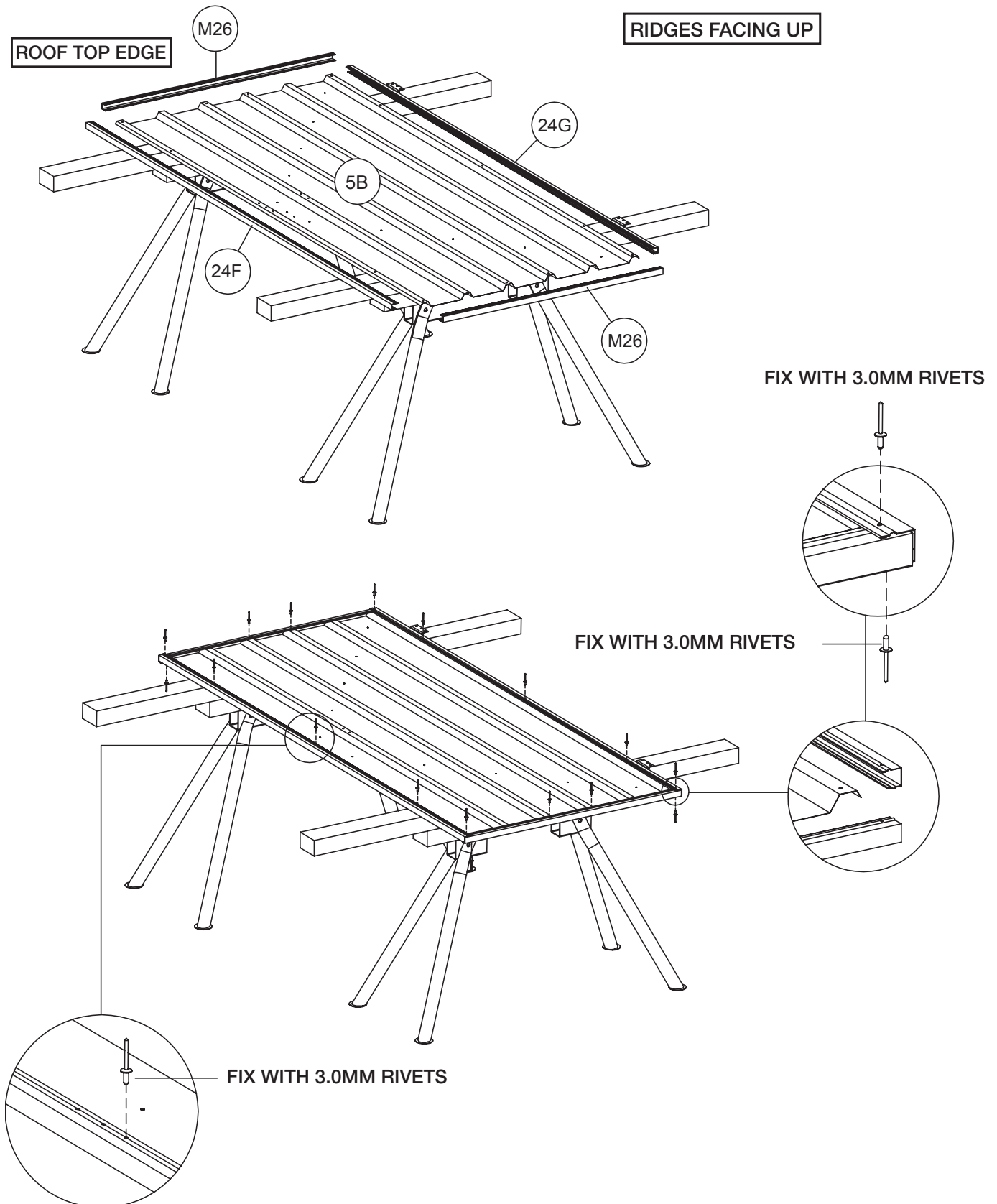

# GardenShed 1.5 x 0.8 x 2.0m

## Step 6: Assemble the front door (continued)

Once channels are fitted to both doors, align 2x part U12 (brace) and part W (joining brace) with holes on the back of the door and position temporarily with some tape or simply hold in place.

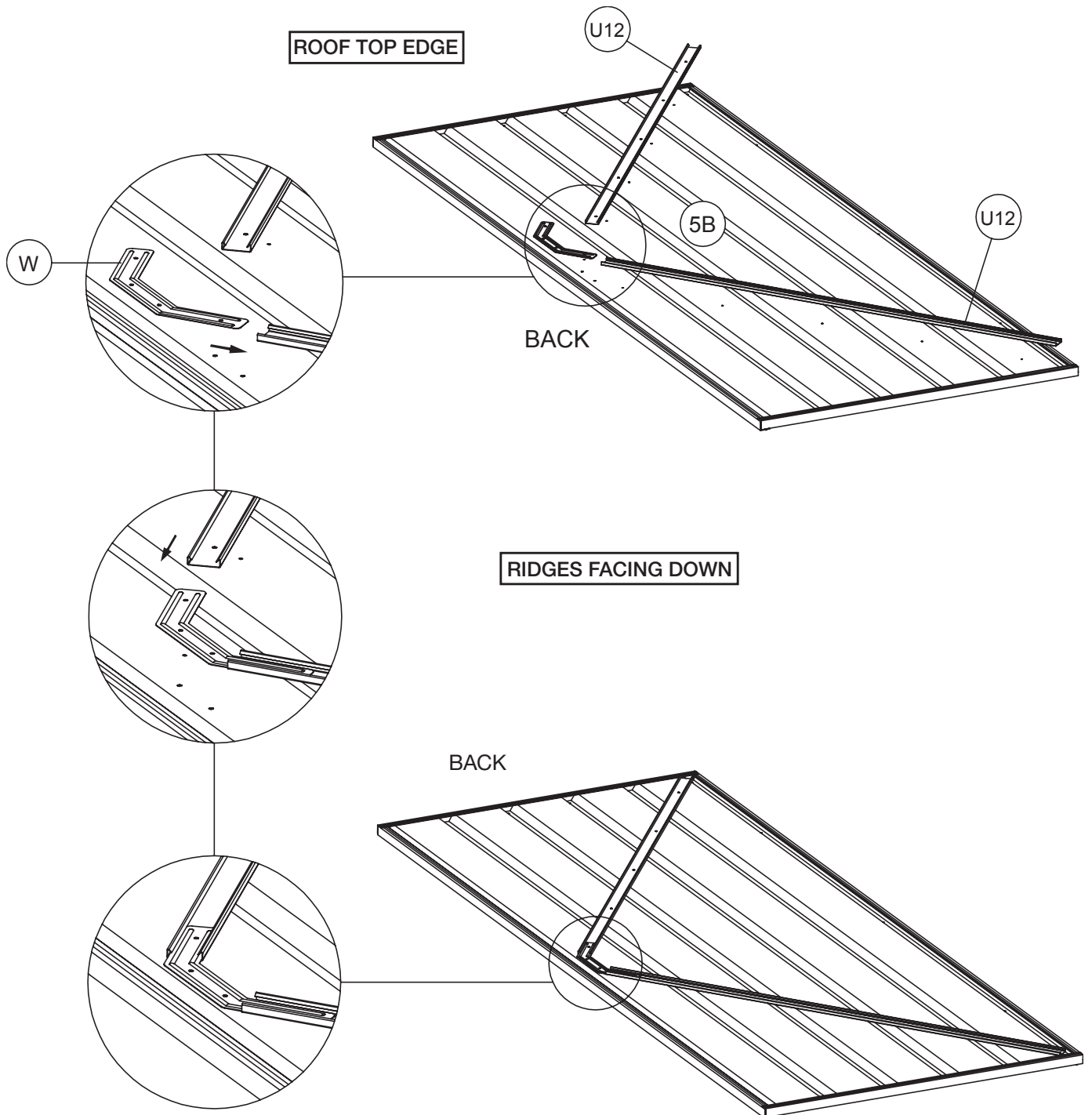

**Step 6:** Assemble the front door (continued)

Turn door over with bracing aligned with holes (make sure the ridges of the door are facing up) and fix the bracing with the provided 3.0 x 10mm rivets through the front of the panel. Then turn door over and insert plastic stoppers at the ends of braces as shown below. Note: When fixing the bracing to door ensure you are riveting through the front panel as shown in the diagram below.

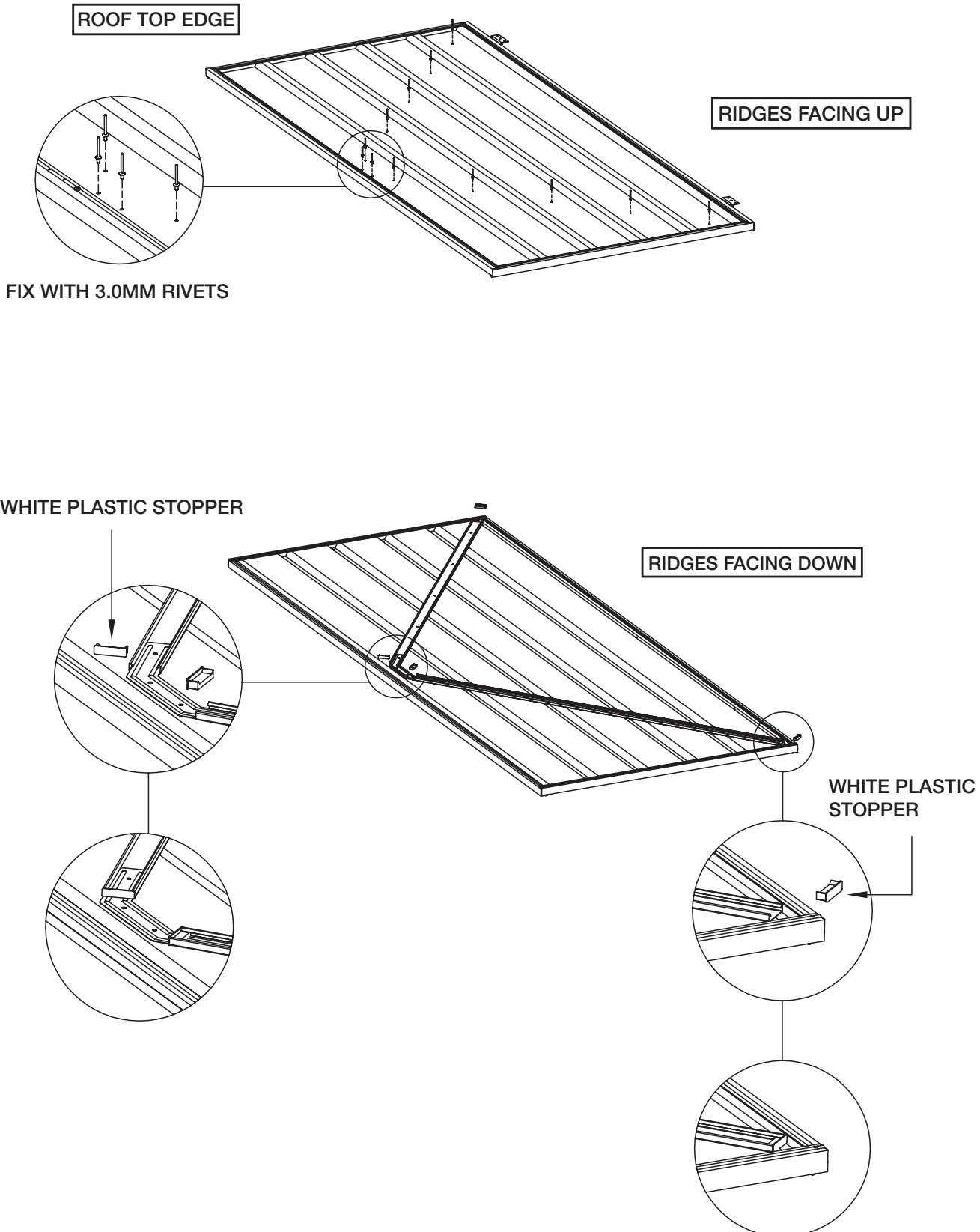

# GardenShed 1.5 x 0.8 x 2.0m

## Step 6: Assemble the front door (continued)

Fit part 5B (assembled door) to the front wall panel as per the diagram below. Use rivet gun to fix the door using the pre-drilled holes. Fix the pad bolt (but NOT its keeper at this stage) using the pre-drilled holes with the self-tapping screws (or rivets) provided.

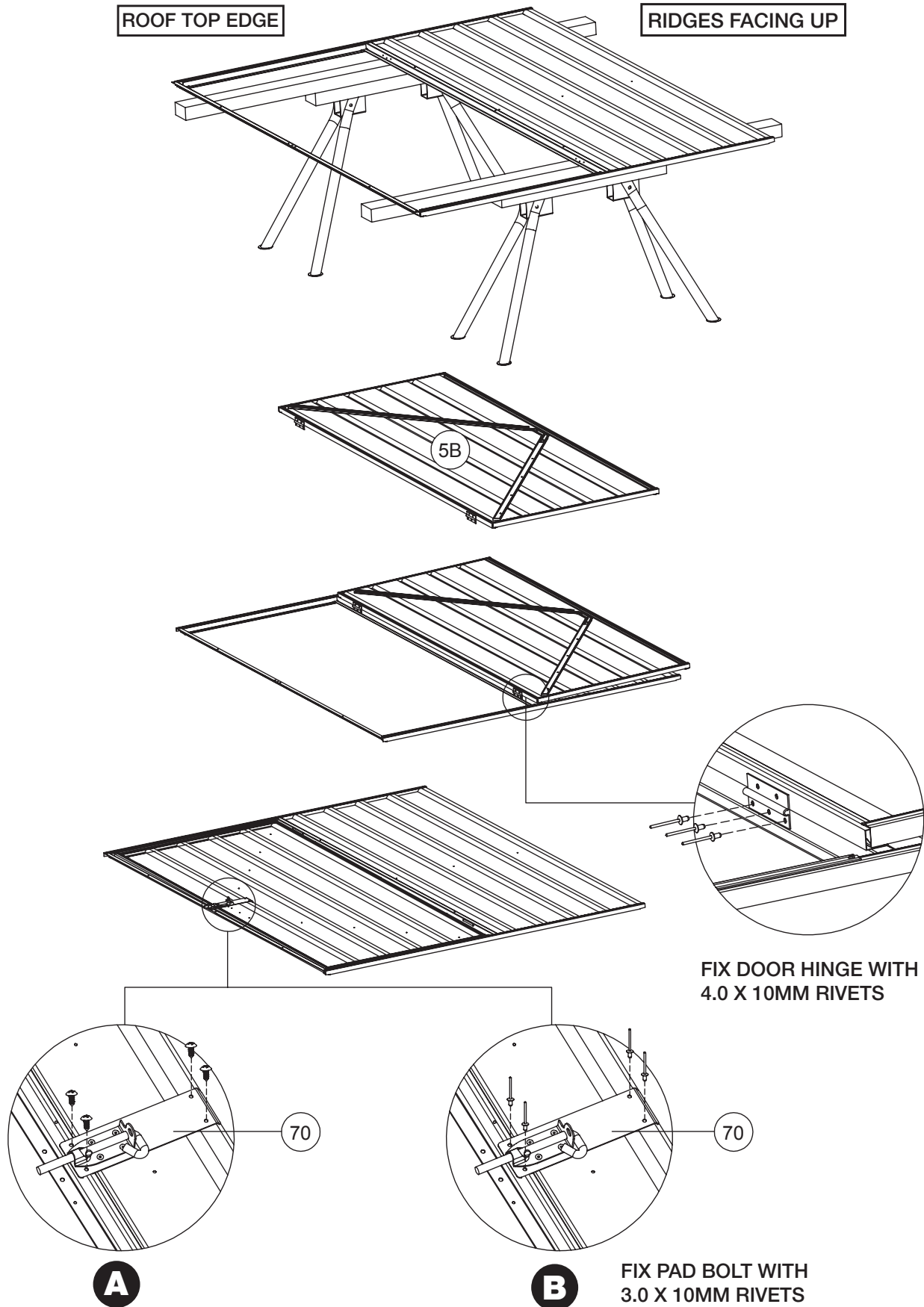



**Step 7: Fit the panels together**

Attach the two side walls to the back wall, then fix the front wall followed by the roof. Fix all of these components together using the provided self-tapping screws. Fix the pad bolt keeper with the provided 16mm self-tapping screws (diagram A) or using rivets (diagram B) at this stage as well. Also attach parts Z17, Z18, Z19 and Z20 (corner brace) to each corner using the self-tapping screws (diagram A) or using rivets (diagram B) provided.

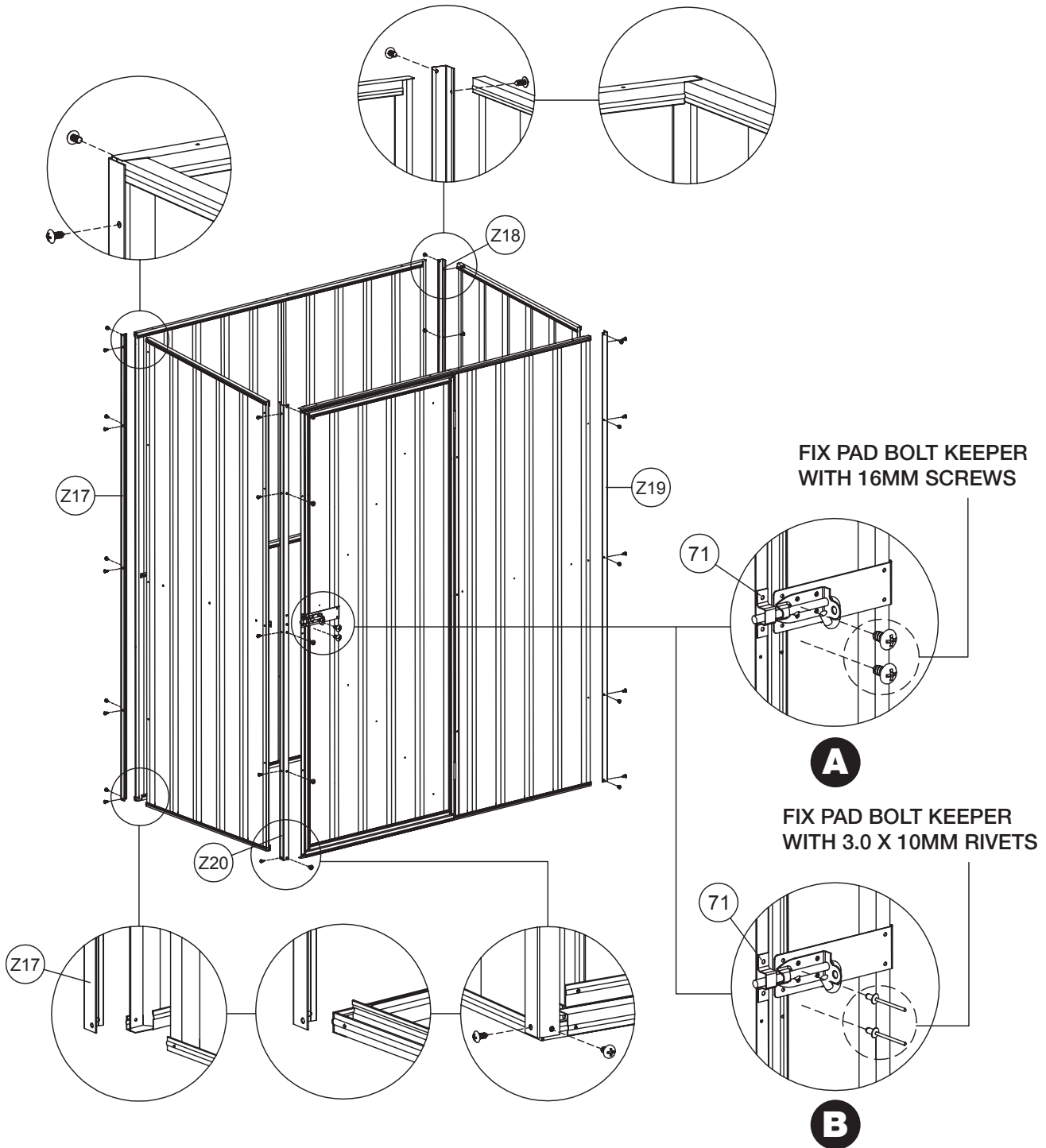

# GardenShed 1.5 x 0.8 x 2.0m

Now fit the bolt down kit as per the diagram below. Strengthen the mid wall braces by applying part 72 (mid wall brace bracket) on each corner if necessary.

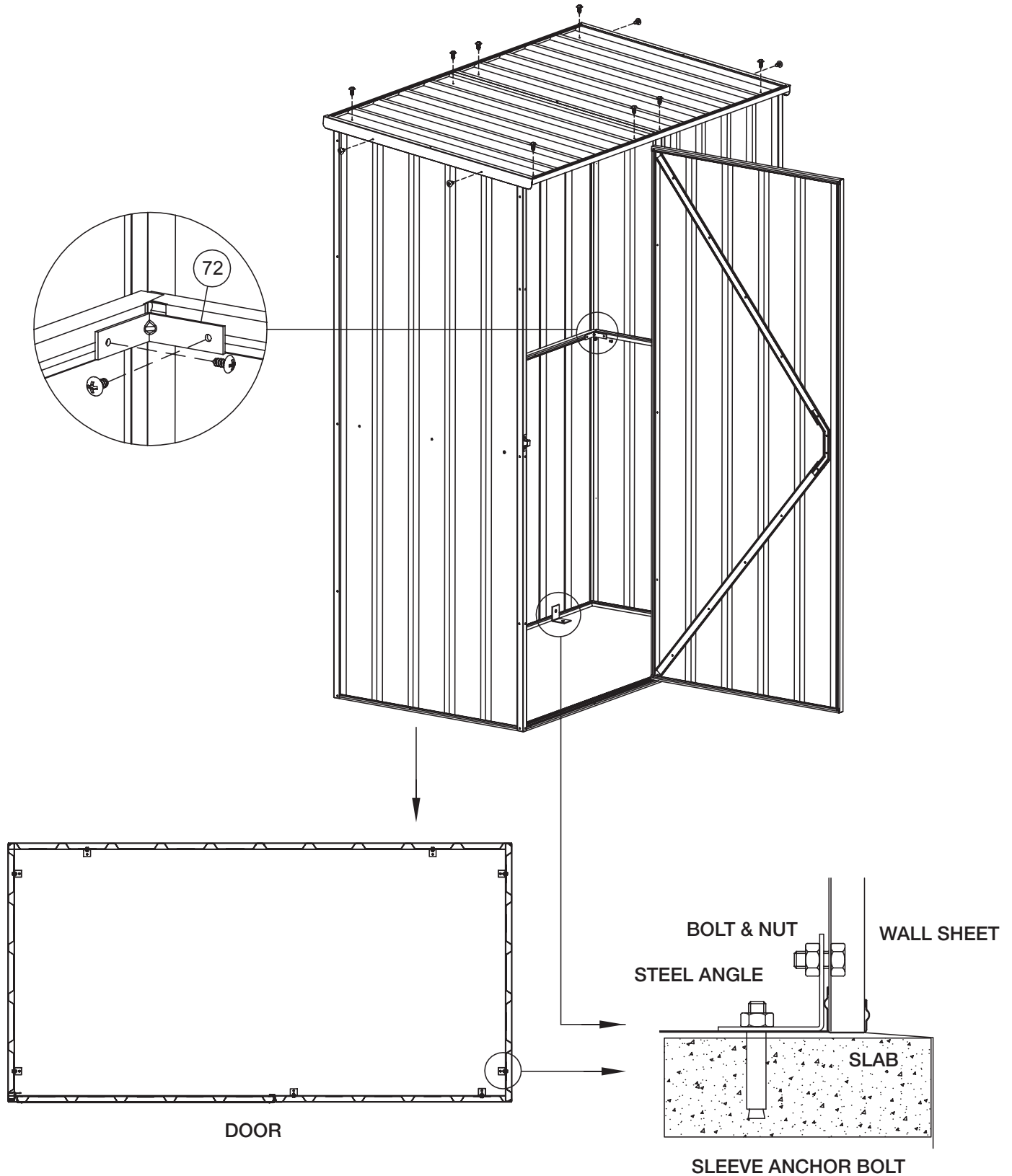

For safety apply channel safety cover (L type) to part 32 (channel) and channel safety cover (R type) to 33R (channel). Also apply the self-tapper covers to screw ends visible in the walls on the inside of the shed as per the diagram below.

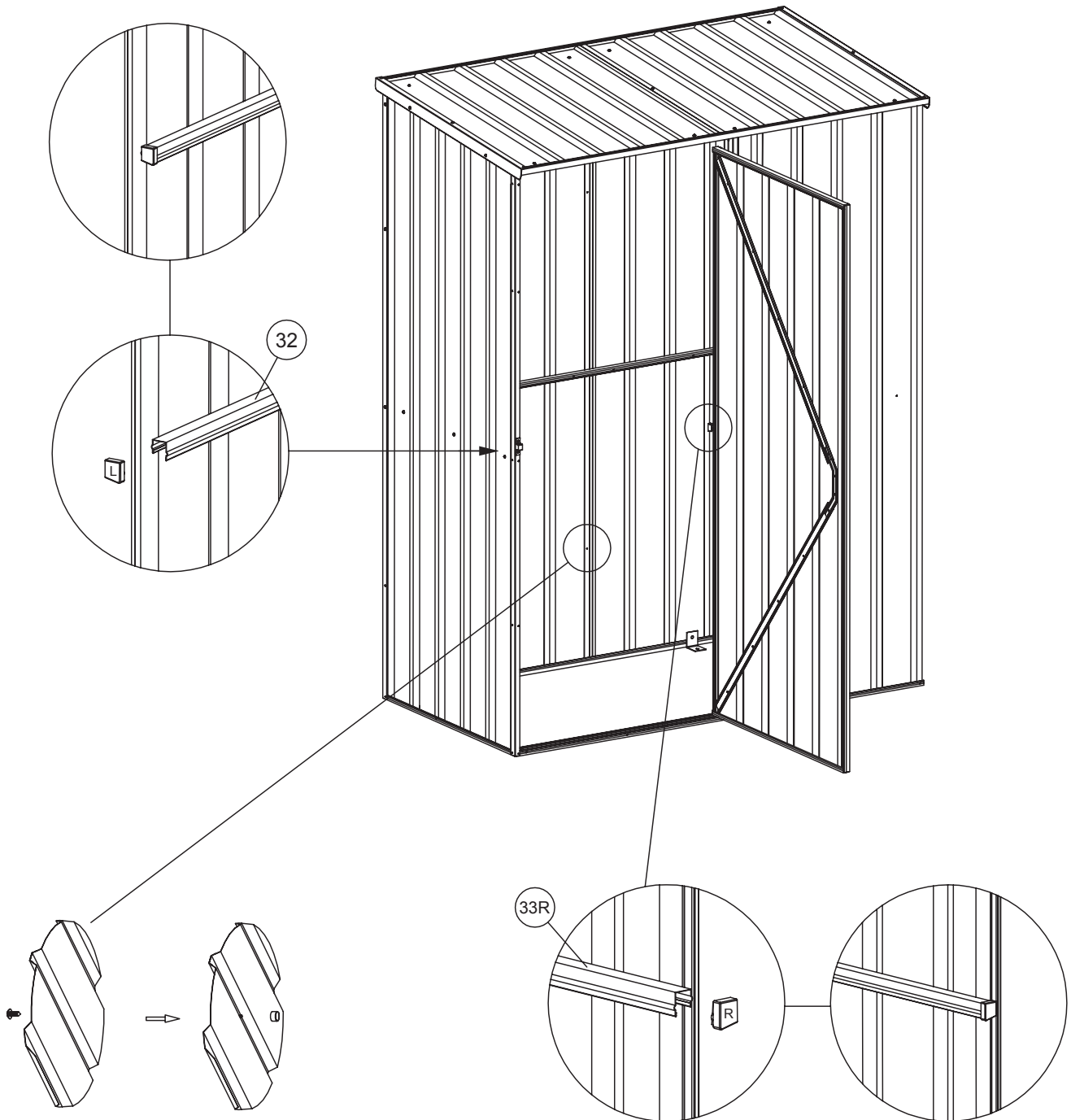

# GardenShed 1.5 x 0.8 x 2.0m

The door can be hinged on the opposite side as well. Align the door with the edge and make the holes using a cordless drill. Remove the pins from the hinges and reverse their direction before you attach the door. If you are concerned about the visibility of any pre-drilled holes, you can fill them with rivets. Perform the same procedure for the pad bolt.

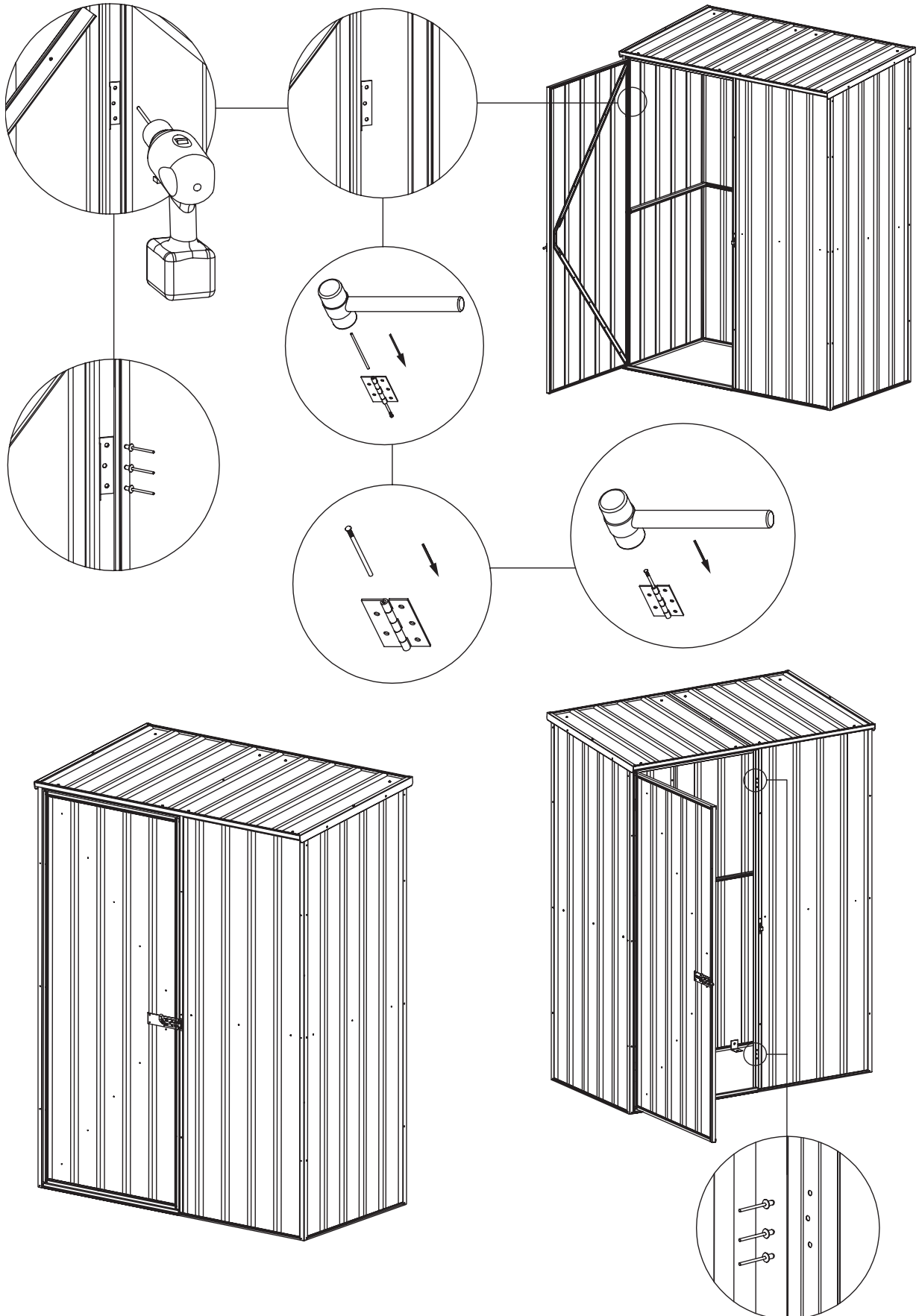

**Warranty statement:**

This warranty against defects is given by:

Pinnacle Hardware.

Business Address: 28 Hudson Court, Keysborough VIC 3173

Ph: 1800 349 776

Email: support@pinnacle.net.au

**New Zealand customers please contact:**

HARCO (Harkness & Young Ltd)

Ph: 09 276 4071

Email: sales@harknessyoung.co.nz

**Details of Manufacturer's Warranty**

This product comes with a 15 year limited structural warranty ("the Warranty Period") from the date of purchase. This warranty also applies where there are missing or damaged parts identified in the parts list referred to in the instruction kit within the product packaging.

Please ensure that you keep this warranty form in a safe place along with your proof of purchase.

**Product:** .....

**Place of purchase & Postcode:** .....

**Date of Purchase:** ..... /..... /.....

The benefits of this warranty are in addition to your rights under the Australian Consumer Law (ACL) and in particular, the guarantees implied under the ACL and any other rights and remedies of the consumer under a similar law in relation to the goods and services to which this warranty relates.

**Process of claiming warranty:**

To make a claim under the warranty within the warranty period, you will need to contact the manufacturer directly by phone or email:

**Claims Department contact number:** 1800 349 776

**Claims Department email:** support@pinnacle.net.au

You will be required to produce proof of purchase (this is at discretion of the manufacturer) at the time of the claim.

The manufacturer bears the cost of replacing the products or spare parts or repairing the products and reasonable direct expenses of claiming under this warranty:

– Where parts are replaced, the manufacturer will bear the cost of sending the spare part and will endeavour to deliver it to the customer's nearest reseller within 10 working days for the customer to pick up. At such time the customer may be required to return the alleged faulty parts.

– Where assessment is required in case of replacing or repairing the product, the manufacturer will appoint an assessor within 10 working days to identify the alleged defect. The manufacturer will bear the repair costs by appointing a local tradesman. The manufacturer may choose to replace the product if the repair or the cost of repair is not feasible. The replacement product will be available for collection from the nearest reseller within 10 working days. The customer will bear the cost of assembly for the replacement product.

# GardenShed 1.5 x 0.8 x 2.0m

## IMPORTANT

### 1. Manufacturer's Disclosure

This warranty against defects shall not apply in the following situations:

- A) Where the product is not assembled in accordance with the instructions provided in the product kit.
- B) Where the product is used to store corrosive materials such as fertilizer, chlorine etc;
- C) Where the damage to the product is caused by storms.

### 2. Notes

This product is weatherproof to a certain level; however driving windy rain may cause the product to leak. Condensation may also occur in some weather conditions such as extreme heat or cold. The product should only be used for storing items such as gardening equipment and should not be used for articles that may be prone to damage if they come into contact with moisture.

We strongly recommend you use a waterproof sealant to fill any gaps or joins in order to minimise the risk of water entering.

### 3. Major Defects

If the manufacturer is satisfied that the defect is a major defect, the purchase price may be refunded in lieu of providing a replacement product or repairing the product.

Our goods come with guarantees that cannot be excluded under the Australian Consumer Law. You are entitled to a replacement or refund for a major failure and for compensation for any other reasonably foreseeable loss or damage. You are also entitled to have the goods repaired or replaced if the goods fail to be of acceptable quality and the failure does not amount to a major failure.