

WAGNER

**CLICK
&
PAINT**
TECHNOLOGY

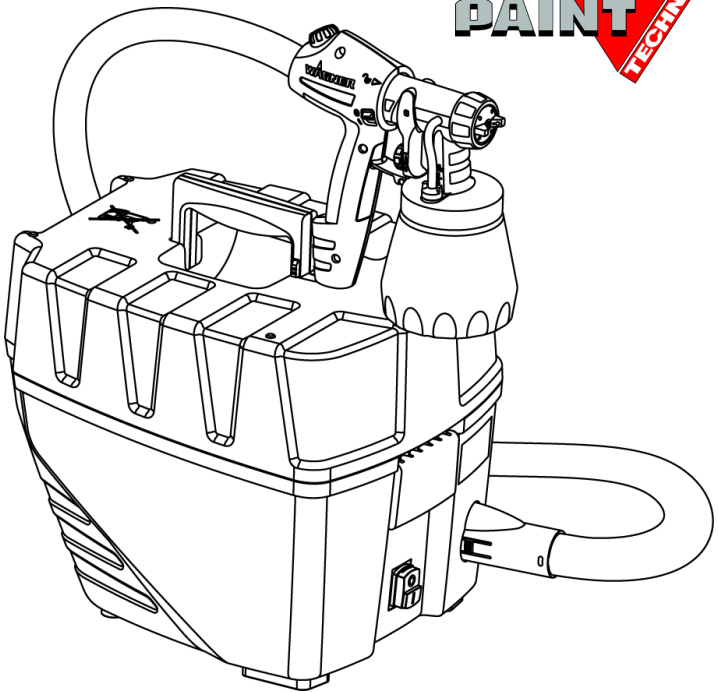

2 Jahre
Garantie

2 years
Guarantee

2 ans de
garantie

2 jaar
garantie



W 867 E
D/GB/F/NL



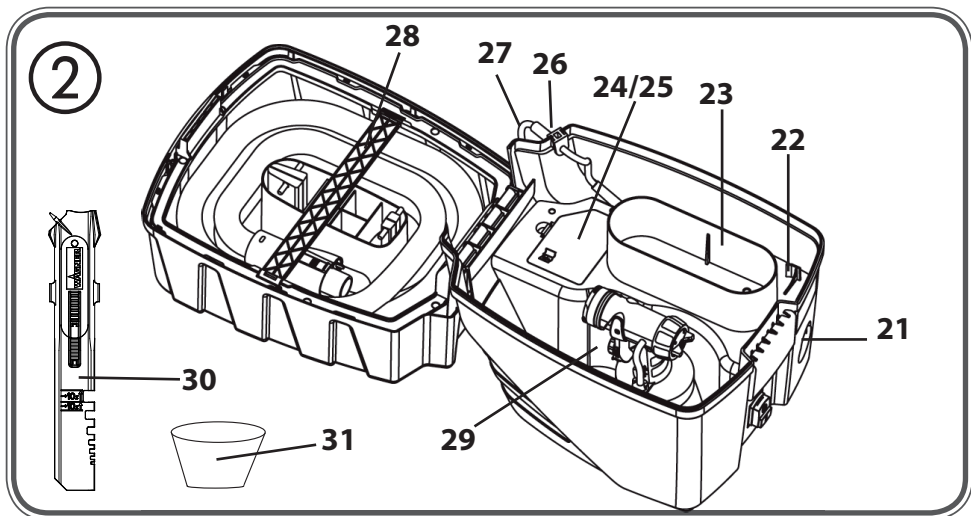
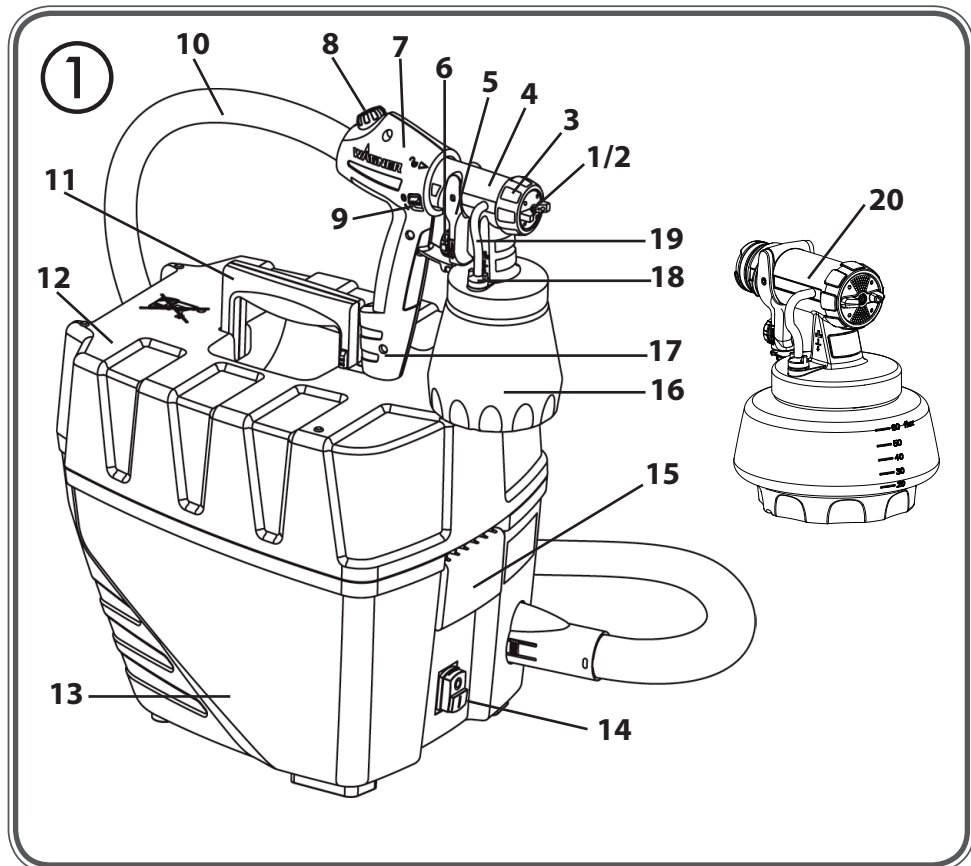

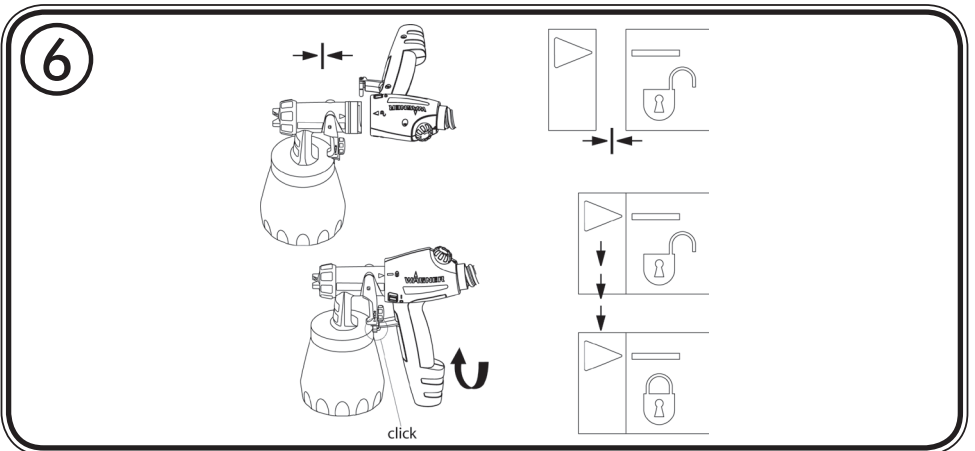
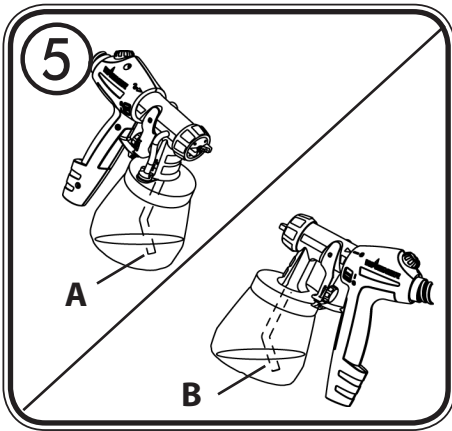
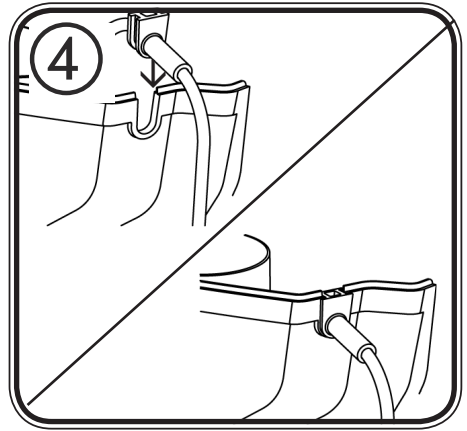
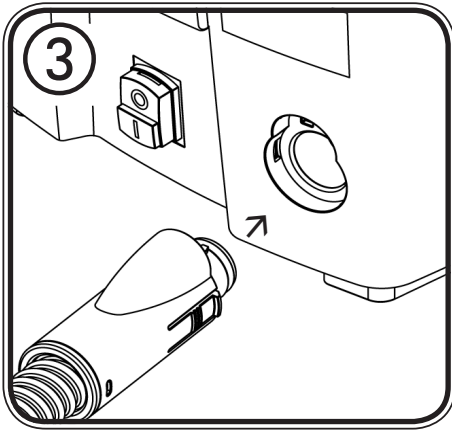

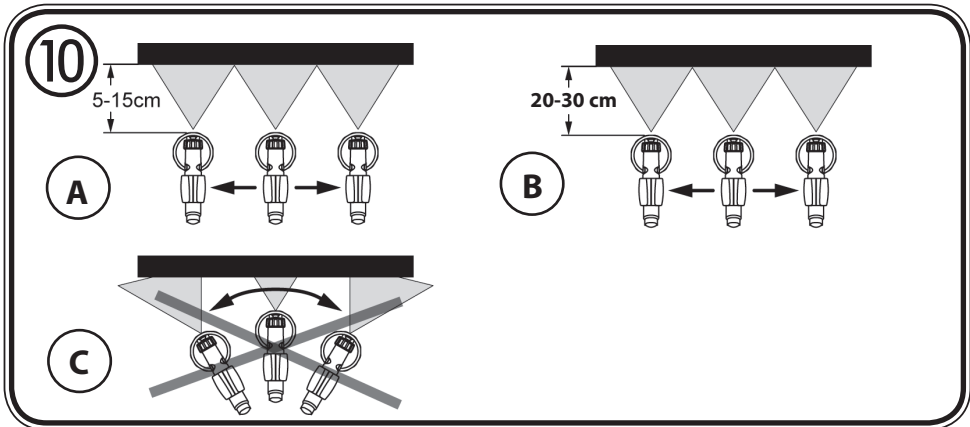
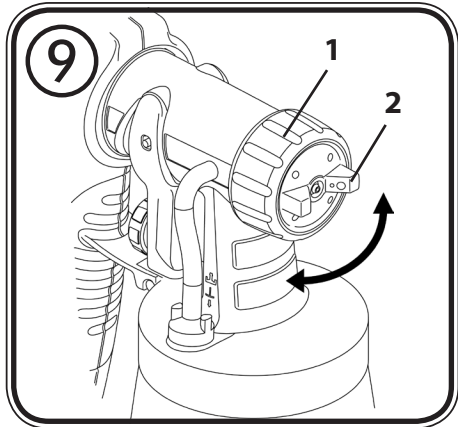
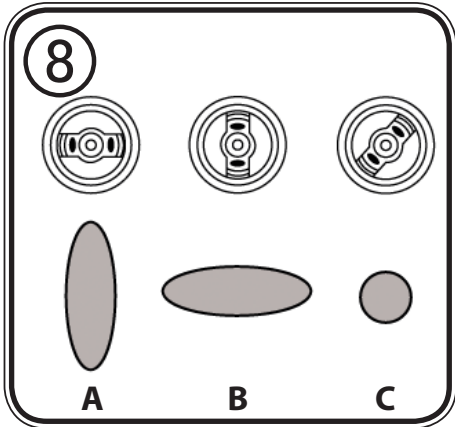
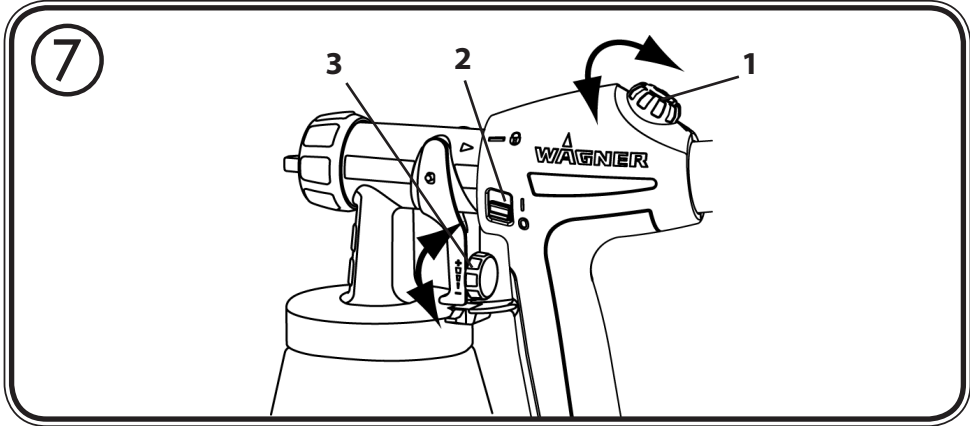

11

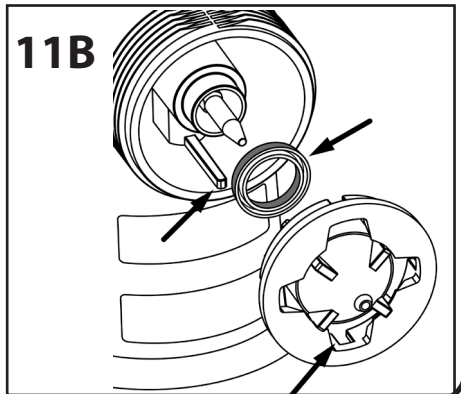
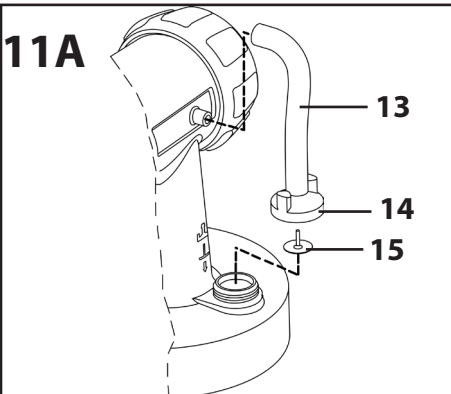
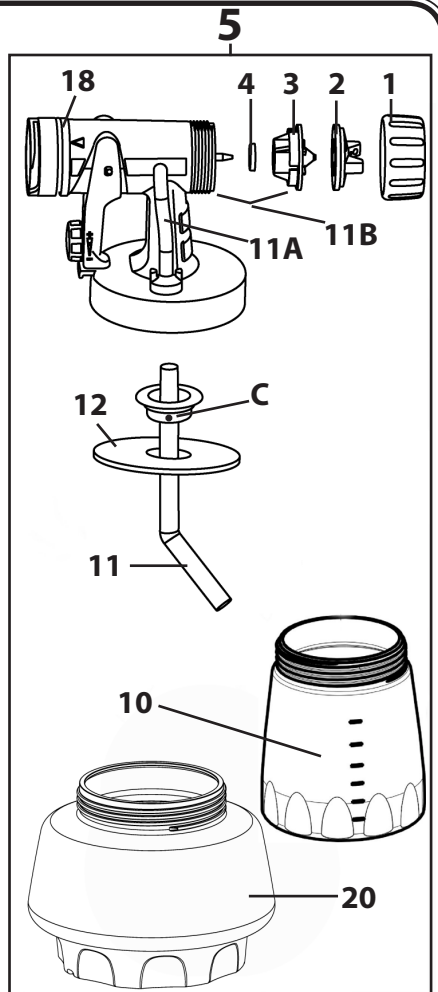
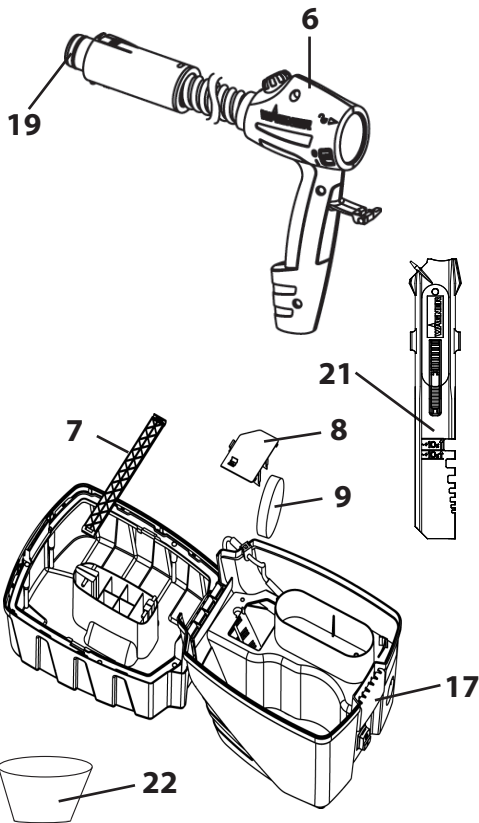

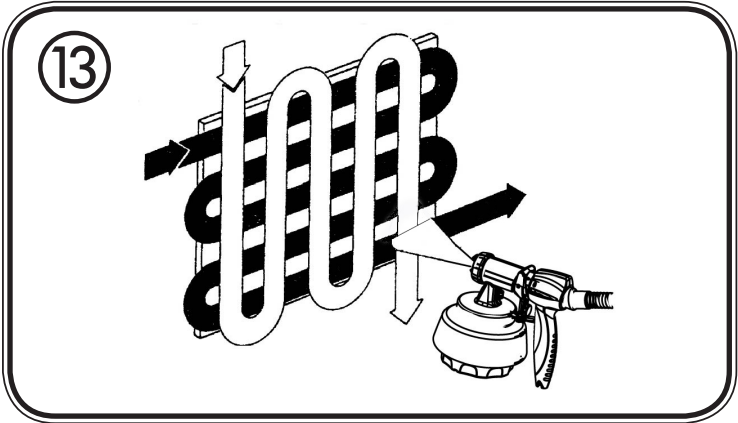
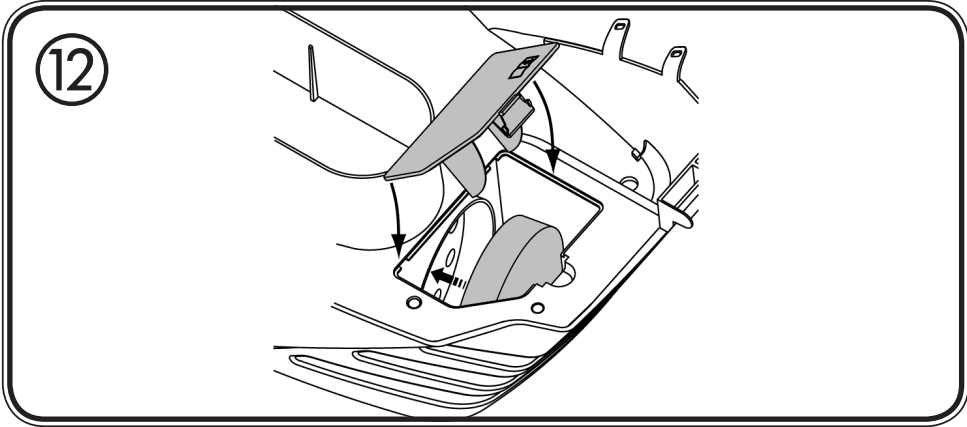

D

.....1 - 15

GB

.....16 - 30

F

.....31 - 45

NL

.....46 - 60









.....62

Operating instruction

Congratulations on purchasing your WAGNER spray guns.

You have purchased a proprietary device that requires careful cleaning and care to ensure trouble-free functioning. **Read the operating instructions carefully before using the tool and observe the safety instructions. Keep the operating instructions in a safe place.**

Explanation of symbols used

	This symbol indicates a potential danger for you or for the device. Under this symbol you can find important information on how to avoid injuries and damage to the device.
	Danger of electrical shock
	Indicates tips for use and other particularly useful information.
	Do not sit or stand on the device. Danger of tilting/breaking!
	Devices and accessories marked with this symbol are suitable for processing low-viscosity materials such as paints, glazes, etc..
	Devices and accessories marked with this symbol are suitable for processing interior wall paints (dispersions and latex paints).

General Safety Instructions

Caution!



Read all the instructions. *Non-observance of the instructions below can cause electric shock, fire and or serious personal injuries. The term "power tool" used below covers both mains-operated power tools (with mains lead) and accumulator-operated power tools (without mains lead).*

1. Workplace

- a) Keep your workplace clean and tidy.** *Untidiness and unlit working areas can lead to accidents.*

- b) **Never use the tool in hazardous areas that contain flammable liquids, gases or dusts.** *Power tools generate sparks that can ignite the dust or vapors.*
- c) **Keep children and other persons away when using the power tool.** *You can lose control of the tool if you are distracted.*

2. Electrical Safety

- a) **The tool plug must fit into the socket. The plug may not be modified in any form. Do not use adaptor plugs together with protective-earthed tools.** *Unmodified plugs and suitable sockets reduce the risk of an electric shock.*
- b) **Avoid physical contact with earthed surfaces such as pipes, heating elements, stoves and refrigerators.** *The risk through electric shock increases if your body is earthed.*
- c) **Keep the equipment away from rain and moisture.** *The risk of an electric shock increases if water penetrates electrical equipment.*
- d) **Do not misuse the mains lead by carrying the tool by the lead, hanging it from the lead or by pulling on the lead to remove the plug. Keep the lead away from heat, oil, sharp edges or moving tool parts.** *Damaged or twisted leads increase the risk of an electric shock.*
- e) **If you work outdoors, use only extension leads that are approved for outdoor use.** *The use of an extension lead that is suitable for outdoors reduces the risk of an electric shock.*

3. Safety of Persons

- a) **Be attentive. Pay attention to what you are doing and work sensibly with a power tool. Do not use the tool if you are tired or under the influence of drugs, alcohol or medication.** *Just a moment of inattentiveness while using the tool can lead to serious injuries.*
- b) **Wear personal safety equipment and always wear safety goggles** *Wearing personal protective equipment, such as dust mask, non-slip safety shoes, safety helmet or ear protection, depending on the type of power tools, reduces the risk of injury.*
- c) **Avoid accidental starting-up. Ensure that the switch is in the "OFF" position before inserting the plug into the socket.** *Accidents can occur if you carry the power tool while your finger is on the switch or if you connect the power tool to the power supply which it is on.*
- d) **Remove setting tools or wrenches before switching on the power tool.** *A tool or wrench that is in a rotating tool part can lead to injuries.*
- e) **Do not overestimate your abilities. Ensure that you are standing securely and have your balance at all times.** *This ensures that you can control the tool better in unexpected situations.*
- f) **Wear suitable clothing. Do not wear wide clothing or jewelry. Keep your hair, clothes and gloves away from moving parts.** *Loose clothing, jewelry or long hair can be caught in moving parts.*

- g) This appliance is not intended for use by persons (including children) with reduced physical, sensory or mental capabilities, or lack of experience and knowledge, unless they have been given supervision or instruction concerning use of the appliance by a person responsible for their safety.** *Children should be supervised to ensure that they do not play with the appliance.*

4. Careful Handling and Use of Power Tools

- a) Do not overload the tool. Use the power tool designed for the work that you are doing.** *You work better and safer in the specified performance range if you use the suitable power tool.*
- b) Do not use power tools whose switch is defective.** *A power tool that cannot be switched on or off is dangerous and has to be repaired.*
- c) Remove the plug from the socket before carrying out tool settings, changing accessories or putting the tool away.** *This precautionary measure prevents unintentional starting of the tool.*
- d) Store unused power tools so that they are inaccessible to children. Do not let persons use the tool who are not familiar with it or who have not read these instructions.** *Power tools are dangerous when they are used by inexperienced persons.*
- e) Take proper care of your tools. Check whether the moving parts function trouble-free and do not jam, whether parts are broken or damaged so that the tool function is impaired. Have damaged parts repaired before using the tool.** *Many accidents have their origin in power tools that have been maintained badly.*
- f) Use the power tool, accessories, insert tools, etc. in accordance with these instructions and in a fashion specified for this special tool type. Take the working conditions and the activity to be carried out into consideration.** *The use of power tools for purposes other than the intended ones can lead to dangerous situations.*

5. Service

- a) Have your tool repaired only by qualified specialist personnel and only with original spare parts.** *This ensures that the tool safety is maintained.*
- b) If the supply cord is damaged, it must be replaced by the manufacturer or its service agent or a similarly qualified person in order to avoid a safety hazard.**

Safety Instructions for Spray Guns



ATTENTION! EXPLOSION HAZARD!

Do not store materials with a flash point below 21°C in the basic device! Only store materials in the basic device in containers that close airtight! Remove any material that may have leaked into the basic device immediately and allow the device to dry completely before using it! Do not store materials contained solvents in the basic device during operation!

● **CAUTION!** Wear breathing equipment: Paint mist and solvent vapors are damaging to health. Always wear breathing equipment and only work in well ventilated rooms or using supplementary ventilating equipment. It is advisable to wear working clothing, safty glasses, ear protection and gloves.

**CAUTION:**

Danger of injury! Never point the spray stream towards human beings or animals.

- The spray gun is to be used only for paints and solvents with a 21°C (32° in UK) flashpoint or higher (See information on the material tin. Hazard class A II and A III permitted).
- Do not use the spray guns to spray flammable substances.
- The spray guns are not to be cleaned with flammable solvents which have a flashpoint under 21°C.
- Caution against dangers that can arise from the sprayed substance and observe the text and information on the containers or the specifications given by the substance manufacturer.
- Do not spray any liquid of unknown hazard potential.
- The device may not be used in workplaces covered by the explosion-protection regulations.
- To avoid the hazard of explosion when spraying, provide for effective natural or artificial ventilation.
- There must be no sources of ignition such as, for example, open fires, smoke of lit cigarettes, cigars and tobacco pipes, sparks, glowing wires, hot surfaces, etc. in the vicinity during spraying.
- Ensure that no solvent vapors are sucked in by the unit. Do not spray onto the unit!
- The spray gun is not a toy; children must therefore not be allowed to handle it or play with it.
- Before working on the spray gun remove the power plug from the socket.
- Cover areas that are **not** to be sprayed. When working keep in mind that wind, for example, may transport paint mist over great distances and cause damage.
- The units may only be used with a functional valve. **If paints rises in the ventilating hose (Fig. 12 A, item 14) do not operate the unit further!** Dismantle and clean the ventilating hose, valve and diaphragm and replace the diaphragm if necessary.
- Do not lay the spray gun.
- The device is equipped with a thermal release which disconnects the device in case of overheating. In this case, turn off the device, remove the plug and let the device cool down for at least 1/2 hour. Eliminate the cause of heating, e.g. bent hose, soiled air filter, slots for air intake covered.

With original WAGNER accessories and spare parts, you have the guarantee that all safety regulations are fulfilled.

Technical Data	
Max. viscosity	170 DIN-s
Max. flow rate:	
Interior wall paint	375 ml/min
Varnish paints, glazes, etc.	200 ml/min
Power source	230 - 240 V~
Power consumption	570 W
Atomizing output:	130 W
Double insulation	☐

Technical Data



Sound pressure level	80 dB (A)
Oscillation level	< 2.5 m/s ²
Air hose length	3.5 m
Weight	approx. 6.3 kg

Description (Figs. 1+2)

1) Air cap	2) Tip
3) Union nut	4) Perfect Spray spray attachment
5) Trigger guard	6) Material volume regulation
7) Gun handle	8) Air volume control
9) ON/OFF switch	10) Air hose
11) Carry handle	12) Cover
13) Bottom section	14) Main switch
15) Closure	16) Container
17) Gun holder	18) Valve
19) Ventilating hose	20) WallPerfect spray attachment
21) Air hose connection	22) Fastener for radiator/detail spray attachment (accessory)
23) Deposition tray for hardware	24) Cover of air filter compartment
25) Air filter	26) Cable grommet
27) Power cable	28) Air hose retainer
29) Deposition tray for spray attachments	30) Stirring rod
31) Feed hopper	

Field of application

Many different coating substances can be processed with the W867.
A different spray attachment must be used, depending on the coating substance:

Coating Materials	Spray attachment
Low-viscosity coating substances: Water- and solvent-based paints, finishes, primers, 2-component paints, clear finishes, automotive finishes, staining sealers and wood sealer-preservatives.	Perfect Spray (anthracite) 
Interior wall paint (dispersions and latex paint)	WallPerfect (white) 

Coating Materials Suitable for Use

Interior wall paint (dispersions and latex paint)
Water- and solvent-based paints, finishes, primers, 2-component paints, clear finishes, automotive finishes, staining sealers and wood sealer-preservatives.

Coating Materials Not Suitable for Use

Materials that contain highly abrasive components, facade paint, caustic solutions and acidic coating substances. Materials with a flash point below 21°C.

Preparation of the workplace (for interior wall paint)



Cover all surfaces and objects that should not be sprayed, or remove them from the work area.

Silicate paint corrodes glass and ceramic surfaces upon contact! All such surfaces must therefore be completely covered.

Preparation of the Coating Material



a) For low-viscosity coating substances

The enclosed spray attachment can be used to spray paints, varnishes and glazes that are undiluted or slightly diluted. Detailed information is available in the technical data sheet of the manufacturer (→ Internet download).

1. Stir the material up and put the required amount into the paint container.

Thinning recommendation	
Sprayed material	
Glazes	undiluted
Wood preservatives, mordants, oils, disinfection agents, plant protective agents	undiluted
Paints containing solvents and water-soluble paints, primers, vehicle coating paints, thick-film glazes	dilute by 5 - 10%

2. If the convey capacity is too low, add 5 - 10% dilution step-by-step until the convey capacity fulfils your requirements.



b) For interior wall paint



Spray material that is at least at room temperature (e.g. diluted with warm water) provides a better spray result.

Attention! Do not heat spray material above 40°C.

Interior wall paints can be sprayed undiluted or slightly diluted with the spray attachment provided. Detailed information is available in the technical data sheet of the manufacturer (→ Internet Download).

1. Stir the material thoroughly and dilute it in the container as per the recommended dilution (an agitator is recommended for stirring).

Thinning recommendation

Sprayed material	
Interior wall paint (dispersions and latex paint)	dilute by 10 %

- If the feed rate is too low even at maximum flow setting, dilute in steps of 5 - 10 % until the feed rate meets your requirements.

Start-up

Before connecting to the mains supply, be sure that the supply voltage is identical with the value given on the rating plate.



ATTENTION: Do not sit or stand on the device. Danger of tilting/breaking!

- Always lower the carry handle in the cover before opening the cover. Press the locking device on both sides to this purpose.
- Open the closure (Fig. 1, item 15) and fold open the cover of the device. Open the air hose retainer (Fig. 2, item 28). Remove the air hose and connect it to the air hose connection (Fig. 3). Close the air hose retainer again.
- Unroll the power cable and slide the cable grommet into the provided recess (Fig. 4).



ATTENTION: Do not close the cover if the cable grommet is not positioned correctly. The power cable could otherwise be damaged!

- Remove the spray attachment from the deposition tray. Unscrew the container from the spray attachment.
- Align the ascending tube. (Fig. 5)
If the ascending tube is positioned correctly, the container contents can be sprayed without almost any residue. When working on lying objects: Turn the ascending tube forwards. (Fig. 5A)
Spraying work when working on overhead objects: Turn the ascending tube rearwards. (Fig. 5B)



For easier coating of ceilings and lying objects, we recommend the 60 cm HVLP handle extension. (Order no. 2307 678)

- Place the container on a paper base and fill in the prepared coating material. Screw the container firmly onto the spray attachment.
- Connect the front part of the gun and the gun handle to each other. (Fig. 6)
- Close the device cover and pull the carry handle upwards. This makes the gun holder accessible.
- Put the spray gun onto the gun holder at the device.
- Place the device only on a plane and clean surface. Otherwise, the gun may suck in dust, etc.
- Switch on the main switch at the device (Fig. 1, item 14).
- Remove the spray gun from the gun holder and point it at the object to be coated.
- Press the On/Off switch at the gun handle (Fig. 7, item 2).

Three different spray jet settings can be chosen on the spray gun, depending on the application and target object.

Selecting the Spray Setting

Fig. 8 A = horizontal flat jet → for horizontal surfaces

Fig. 8 B = vertical flat jet → for vertical surfaces

Fig. 8 C = circular jet → for corners, edges and hard-to-reach surfaces

Adjusting the desired Spray Setting (Fig. 9)

With the union nut (1) slightly unscrewed, turn the air cap (2) to the desired spraysetting position (arrow). Then tighten the union nut.



WARNING!

Danger of injury! Never pull the trigger guard while adjusting the air cap.

Adjusting the Material Volume (Fig. 7, item 3)

Set the material volume by turning the regulator on the trigger guard of the spray gun.

- turn to the left → lower material volume

+ turn to the right → higher material volume

Setting the Amount of Air (Fig. 7, item 1)

Depending on the viscosity of the material to be sprayed and the finish of the object to be coated, it may be advisable to vary the amount of air. Very low viscosity materials, such as watery glazes do not have to be atomised with the maximum amount of air. In this case it is advisable to reduce the amount of air and thus minimize the spray vapour.

This also applies for the use of the low-scale and radiator/detail spray attachment (accessory).

- turn to the left → lower amount of air

+ turn to the right → higher amount of air

Spray Technique



a) For low-viscosity coating substances

- The spray result depends heavily on the smoothness and cleanliness of the surface to be sprayed. Therefore the surface should be carefully prepared and kept free of dust.
- Cover all surfaces not to be sprayed.
- Cover screw threads or similar parts of the target object.



It is advisable to test the spray gun on cardboard or a similar surface to find the correct setting.

Important: Begin spraying outside of the target area and avoid interruptions inside the target area.

- The spray movement should come from the arm, not just from the wrist. This ensures that a uniform distance is maintained between the spray gun and the spray surface during the spray operation. Select a distance of 5 - 15 cm, depending on the desired spray jet width.

Fig. 10 A: CORRECT: Even distance to the object.

Fig. 10 C: INCORRECT: Uneven distance causes uneven coating.

- Move the spray gun evenly cross-wise or up-and-down, depending on the spray pattern setting.
- An even movement of the spray gun results in an even surface quality.
- When coating material builds up on the nozzle and air cap (Fig. 10), clean both parts with a solvent or water.



b) For interior wall paint

- Cover all surfaces not to be sprayed.



It is advisable to test the spray gun on cardboard or a similar surface to find the correct setting.

Important: Start at the edge of the area to be sprayed. Start the spray movement first of all, and then press the trigger. Avoid interruptions within the area to be sprayed.

To facilitate operation of the paint sprayer, a practice poster with simple exercises is also included with the device.

- The spray movement should come from the arm, not just from the wrist. This ensures that a uniform distance is maintained between the spray gun and the spray surface during the spray operation. Select a distance of 20-30 cm (gun length is approx. 25 cm), depending on the desired spray jet width.

Fig. 10 B: CORRECT Even distance to the object.

Fig. 10 C: INCORRECT An uneven distance will result in uneven paint application.

- Move the spray gun evenly cross-wise or up-and-down, depending on the spray pattern setting.
- An even movement of the spray gun results in an even surface quality.
- If nozzle and air cap are soiled, clean both parts with water and solvent.



"Cross spray" when using paint with a poor covering capacity or if the surface is highly absorbent (Fig. 13).



Interior wall paint in strong colour shades should be applied at least twice (allow first paint coat to dry first). This will ensure good coverage.

Interruption of Work till 4 Hours

- Turn the machine off.
- During longer breaks, vent the container by briefly opening and then closing it again.
- Clean nozzle openings after an interruption in operation.
- When processing 2-component varnishes, clean the device immediately.

Taking Out of Operation and Cleaning

Proper cleaning is the prerequisite for problem-free operation of the paint application device. No warranty claims are accepted in case of improper or no cleaning.

- 1) Turn the machine off.
- 2) Divide the spray gun. Press the hook (Fig. 6 "click") slightly downwards.

Turn the gun front part and gun rear part against each other.

ATTENTION: Never hold the gun handle under water or immerse it into liquids. Clean the housing only with a moistened cloth.

- 3) Unscrew the container. Empty any remaining coating material back into the material tin.
- 4) Prclean the container and feed tube with a brush. Clean the ventilating bore (Fig.11, item C).
- 5) Pour solvent or water into the container. Screw the container back on.
Use only solvents with a flashpoint over 21°C.
- 6) Assemble the gun again (Fig. 6).
- 7) Turn on the machine and spray the solvent or water into a container or a cloth.
- 8) Repeat the above procedure until the solvent or water emerging from the nozzle is clear.
- 9) Turn off the machine and divide the spray gun.
- 10) Screw of the container and empty it. Pull out the suction tub with container seal.



CAUTION! Never clean seals, diaphragm and nozzle or air holes of the spray gun with metal objects.

The ventilation hose and diaphragm are only solvent-resistant to a limited extent. Do not immerse in solvent, only wipe.

- 11) Pull the ventilating hose (Fig.11 A, item 13) at the top from the gun body. Screw off the valve cover (14). Remove the diaphragm (15). Clean all the parts carefully.
- 12) Unscrew the union nut and remove the air cap and nozzle. Clean the air cap, nozzle seal and nozzle with a brush and solvent or water (Fig. 11, item 5).
- 13) Clean the outside of the spray gun and container with a cloth soaked in solvent or water.
- 14) Assemble the parts again (see "Assembly").

Assembly

The unit may only be operated with an integer diaphragm (Fig. 11A, item 15). Place the diaphragm **with the pin facing upwards** on the bottom section of the valve. Also see the marking on the gun body. Place on the valve cover and screw it closed. Place the ventilating hose on the valve cover and on the nipple at the gun body.

Slide the nozzle seal (Fig. 11, item 4) with the groove (slot) facing forwards into the nozzle (Fig. 11B). Put the nozzle onto the gun body and find the correct position by turning it. Put the air cap onto the nozzle and tighten it using the union nut.

Place the container seal from below on the suction tube and slide it over the collar, while turning the container seal slightly. Insert the suction tube with container seal in the gun body.

Maintenance



WARNING!

Never operate the machine without the air filter; dirt could be sucked in and interfere with the function of the machine. Do not store any objects in the air filter compartment.

Change the air filter if it is soiled. Unplug the power plug. Open the cover of the air filter compartment (Fig. 12). Insert a new air filter into the compartment. Close the cover of the air filter compartment.

In order to mount the gun more easily apply lubricating grease (enclosed) liberally to the O-ring at the spray attachment (Fig. 11, item 18) and to the O-ring of the plug connection of the air hose (Fig. 11, item 19).

Storage

Remove the hose and when storing it in the cover put in the gun handle first.

Spare Parts List (Fig. 12)

Pos.	Designation	Order No.
1	Union nut (Perfect Spray)	0417 319
	Union nut (WallPerfect)	0417 471
2	Air cap (Perfect Spray)	2305 129
	Air cap (WallPerfect)	0417 470
3	Nozzle (Perfect Spray)	2305 131
	Nozzle (WallPerfect)	0417 468
4	Nozzle seal (Perfect Spray)	0417 706
	Nozzle seal (WallPerfect)	0417 465
5	Perfect Spray spray attachment complete with 600 ml container	2309 365
	WallPerfect spray attachment complete with 1300 ml container	2309 366
6	Gun handle with air hose	2309 369
7	Air hose retainer	0420 326
8	Cover of air filter compartment	0420 328
9	Air filter	0420 702
10	Container with cover 600 ml	0414 906
11	Suction tube (Perfect Spray)	0417 357
	Suction tube (WallPerfect)	0417 473
12	Container seal (Perfect Spray)	0417 358
	Container seal (WallPerfect)	0417 474
13	Ventilating hose	2304 027
14	Valve cover	
15	Diaphragm	
16	Lubricating grease	9892 550
17	Closure	0420 701
18	O-ring of spray attachment	0417 308
19	O-ring of air hose	0420 316
20	Container with cover 1300 ml	2305 155
21	Stirring rod	2304 419
22	Feed hopper (3x)	2304 028

The new **CLICK&PAINT SYSTEM** with additional spray attachments and accessories offers the right tool for each work.

Accessories (not included in the delivery)	
Name	Order No.
HVLP handle extension For easier coating of ceilings and horizontal objects.	2307 678
Container with cover 800 ml Ensures that the paint does not dry out and the solvent does not evaporate.	0413 909
Brilliant spray attachment incl. 600 ml container Optimised nozzle and air guidance for brilliant paint results	0417 932
Perfect Spray spray attachment incl. 800 ml. conainer For a rapid paint change. For medium- and large-scale objects and furniture.	0417 914
Small-scale spray attachment incl. 250 ml container For filigree objects, detailed and creative work.	0417 918
Perfect Spray spray attachment incl. 1400 ml container Rapid working at larger objects such as timber houses, garage doors, etc.	0417 917
Detail / Radiator spray attachment incl. 600 ml container For inaccessible places, such as radiators, cupboard corners, recesses etc.	0417 915
WallPerfect spray attachment incl. 1800 ml container For processing interior wall paint We recommend against using the WallPerfect spray attachment with the W550/W560/W610.	2301 734

Further information about the WAGNER range of products for renovating is available under www.wagner-group.com

Environmental protection



The appliance and accessories should be recycled in an environmentally friendly way. Do not dispose of the appliance with household waste. Support environmental protection by taking the appliance to a local collection point or obtain information from a specialist retailer.

Important Note regarding Product Liability!

Due to an EC ordinance in effect since 01.01.1990, the manufacturer is liable for his product only if all parts originate from or were approved by the manufacturer and the devices are assembled and operated correctly. The use of other accessories and spare parts can partially or completely invalidate the liability.

Correction of Malfunctions

Malfunction	Cause	Remedy
No coating material emerges from the nozzle	<ul style="list-style-type: none"> • Nozzle clogged • Material volume setting turned too far to the left (-) • No pressure build-up in container • Container empty • Feed tube loose • Feed tube clogged • Ventilating bore (Fig.12, C) clogged 	<ul style="list-style-type: none"> → Clean → Turn to the right (+) → Tighten container → Refill → Insert → Clean → Clean
Coating material drips from the nozzle	<ul style="list-style-type: none"> • Coating material assembly at air cap, nozzle or needle • Nozzle loose • Nozzle seal worn • Nozzle worn 	<ul style="list-style-type: none"> → Clean → Union nut tighten → Change → Change
Atomisation too coarse	<ul style="list-style-type: none"> • Material volume too large • Material volume adjusting screw turned too far to the right (+) • Nozzle contaminated • Viscosity of coating material too high • Too little pressure build-up in container • Air filter heavily soiled • Amount of air too low 	<ul style="list-style-type: none"> → Turn material volume adjusting screw to the left (-) → Clean → Dilute further → Tighten container → Change → Turn the air volume control to the right (+)
Spray jet pulsates	<ul style="list-style-type: none"> • Coating material in container running out • Nozzle seal worn • Air filter heavily soiled 	<ul style="list-style-type: none"> → Refill → Replace → Change
Coating material causes "paint tears"	<ul style="list-style-type: none"> • Too much coating material applied. 	<ul style="list-style-type: none"> → Turn material volume adjusting screw to the left (-)
Too much fog of coating material (Overspray)	<ul style="list-style-type: none"> • Distance to the object too large • Too much coating material applied • Amount of air too high 	<ul style="list-style-type: none"> → Reduce distance → Turn material volume adjusting screw to the left (-) → Turn the air volume control to the left (-)
Paint in the ventilating hose	<ul style="list-style-type: none"> • Diaphragm soiled • Diaphragm defective 	<ul style="list-style-type: none"> → Clean the diaphragm → Replace the diaphragm

Malfunction	Cause	Remedy
Device does not function	<ul style="list-style-type: none"> • Device overheated 	<ul style="list-style-type: none"> → Unplug the power plug, let the device cool down approx. 30 minutes, do not bend the hose, check the air filter, do not cover the intake slots
Poor covering capacity on the wall	<ul style="list-style-type: none"> • Spray material is too cold • Highly absorbent surface or paint with poor covering capacity • Distance too large 	<ul style="list-style-type: none"> → Heat spray material (to maximum 40°C) → Cross spray (Fig. 13) → Closer to the object

Warning

If the supply cord of this appliance is damaged, it must only be replaced by a repair shop appointed by the manufacturer, because special purpose tools are required.

Warning: Do not connect the blue or brown wire to the earth terminal of the plug! The wires in this mains lead are coloured in accordance with the following code:

blue = neutral **brown** = live

As the colours of the wires in the mains lead of this appliance may not correspond with the coloured markings identifying the terminals in your plug, proceed as follows:

◆ Should the moulded plug have to be replaced, never re-use the defective plug or attempt to plug it into a different 13 A socket. This could result in an electric shock.

◆ Should it be necessary to exchange the fuse in the plug only use fuses approved by ASTA in accordance with BS 1362. 5 Amp fuses may be used.

◆ To ensure that the fuse and fuse carrier are correctly mounted please observe the provided markings or colour coding in the plug.

◆ After changing the fuse, always make sure that the fuse carrier is correctly inserted. With out the fuse carrier, it is not permissible to use the plug.

◆ The correct fuses and fuse carriers are available from your local electrical supplies stockist.

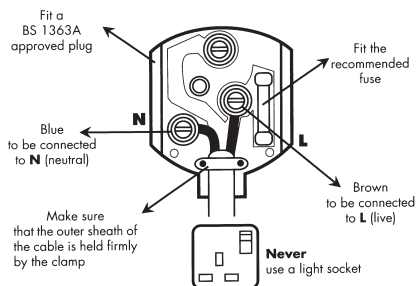

2 years guarantee

The guarantee runs for two years, counting from the date of sale (sales slip). It covers and is restricted to free-of-charge rectification of faults which are demonstrably attributable to the use of faulty materials in manufacture, or assembly errors; or free-of-charge replacement of the defective parts. The guarantee does not cover incorrect use or commissioning or fitting or repair work which is not stated in our operating instructions. Wearing parts are also excluded from the guarantee. The guarantee excludes commercial use. We expressly reserve the right to fulfil the guarantee. The guarantee expires if the tool is opened up by persons other than WAGNER service personnel. Transport damage, maintenance work and loss and damage due to faulty maintenance work are not covered by the guarantee. Under any guarantee claim, there must be proof of purchase of the tool through submission of the original receipt. Wherever legally possible, we exclude all liability for injury, damage or consequential loss, especially if the tool has been used for a purpose other than that stated in the operating instructions, commissioned or repaired other than in accordance with our operating instructions or if repairs are performed by someone who is unqualified. We reserve the right to perform any repairs in excess of those stated in our operating instructions. In case of guarantee or repair, please refer to your point of sale.

**CE Konformitätserklärung**

Wir erklären in alleiniger Verantwortung, dass dieses Produkt den folgenden einschlägigen Bestimmungen entspricht:

73/23/EWG, 89/336 EWG; 2002/95/EG; 2002/96/EG

Angewandte harmonisierte Normen:

EN 55014-1: 2002, EN 55014-2: 2001, EN 61000-3-2/2005, EN 61000-3-3:2001, EN 60335-1:2004

**CE Declaration of Conformity**

We declare under sole responsibility that this product conforms to the following relevant stipulations:

73/23/EWG, 89/336 EWG; 2002/95/EG; 2002/96/EG.

Applied harmonised norms:

EN 55014-1: 2002, EN 55014-2: 2001, EN 61000-3-2/2005, EN 61000-3-3:2001, EN 60335-1:2004

**CE Déclaration de conformité**

Nous déclarons sous notre responsabilité que ce produit est en conformité avec les réglementations suivantes:

73/23/EWG, 89/336 EWG; 2002/95/EG; 2002/96/EG.

Conforme aux normes et documents normalisés:

EN 55014-1: 2002, EN 55014-2: 2001, EN 61000-3-2/2005, EN 61000-3-3:2001, EN 60335-1:2004

**CE Conformiteitsverklaring**

Wij verklaren dat dit product voldoet aan de volgende normen:

73/23/EWG, 89/336 EWG; 2002/95/EG; 2002/96/EG.

En normatieve documenten:

EN 55014-1: 2002, EN 55014-2: 2001, EN 61000-3-2/2005, EN 61000-3-3:2001, EN 60335-1:2004

WAGNER

J. Wagner GmbH
Otto-Lilienthal-Str. 18
D-88677 Markdorf

W. van der Hoeven
Managing Director

i. V. J. Ulbrich
Development
Manager

D

J. Wagner GmbH

Otto-Lilienthal-Str. 18

D-88677 Markdorf

☎ Hotline 0180/1000 227

☎ +49/75 44/505-169

WAGNER

CZ

M.A.T Ltd.

Na Roudne 176

301 62 Plzen

☎ +420 376 709 205 ☎ +420 376 709 263

WAGNER

B

Wagner Spraytech Belgique

Veilinglaan 58

1861 Meise-Wolvertem

☎ +32/2/2 69 46 75 ☎ +32/2/2 69 78 45

WAGNER

E

J. Wagner Spraytech Ibérica S.A.

Ctra. N-340, Km 1245,4

08750 Molins de Rei (Barcelona)

☎ +34/93/6 80 00 28 ☎ +34/93/6 68 01 56

WAGNER

F

Wagner France S.a.r.l.

Parc de Gutenberg - Bâtiment F8

8 voie la Cardon

91127 Palaiseau Cedex

☎ 0 825 011 111 ☎ 0169 81 72 57

WAGNER

SLO

Adresa servisa:

GMA Elektromehanika d.o.o.

Cesta Andreja Bitenca 115,

Ljubljana 1000/Slowenien

☎ +386(1)/583 83 04 ☎ +386(1)/518 38 03

WAGNER

DK/S

Wagner Spraytech**Scandinavia A/S**

Helgeshøj Allé 28

DK-2630 Tåstrup

☎ +45/43 27 18 18 ☎ +45/43 43 05 28

WAGNER

H

Magyarországi szerviz

Hondimpex KFT.

Kossuth L. u. 48-50

8060 Mór

☎ +36(-22)/407 321 ☎ +36(-22)/407 852

WAGNER

CH

J. Wagner AG

Industriestraße 22

9450 Altstätten

☎ +41/71/7 57 22 11 ☎ +41/71/7 57 23 23

WAGNER

PL

PUT Wagner Service

ul. E. Imieli 14

41-605 Swietochlowice

☎ +48/32/2 45 06 19 ☎ +48/32/2 41 42 51

WAGNER

SK

Phobos Corporation Spol.r.o

Stanica 6, 92700 Sala

Slowakei

☎ +421/31/7 70 78 84 ☎ +421/31/7 70 22 42

WAGNER

HR

Adresa servisa:

EL-ME-HO

Horvatinčićev put 2

10436 Rakov Potok/Kroatien

☎/☎ +385(-1)65 86 - 028

WAGNER

NL

Wagner Spraytech Benelux B.V.

Zoonebaan 10

3542 EC Utrecht

☎ +31/30/2 41 41 55 ☎ +31/30/2 41 17 87

WAGNER

AUS

Wagner Spraytech**Australia Pty. Ltd.,**

14-16 Kevlar Close,

Braeside, VIC 3195/Australia

☎ +61/3/95 87 20 00 ☎ +61/3/95 80 91 20

WAGNER

GB

Wagner Spraytech (UK) Ltd.

The Coach House

2 Main Road

Middleton Cheney OX17 2ND

☎ UK-Helpline 0844 335 0517

5 p per minute (landline)

WAGNER

www.wagner-group.com

Irrtümer und Änderungen vorbehalten.
 Not responsible for errors and changes.
 Sous réserves d'erreurs et de modifications.
 Fouten en wijzigingen voorbehouden.

Part. No. 2308 351 11/2009_RS

© Copyright by J.Wagner GmbH