

installing postform edged benchtops

Things you need to know

- Please check the colour and finish of your benchtop before you start cutting your new workspace. Benchtops cannot be returned or exchanged once they have been cut, modified or installed.
- Never place hot items directly onto your benchtop as this will cause damage to the surface.

- Never cut directly onto your benchtop as this could create fine scratches.
- Always remember to use Personal Protection Equipment when cutting and installing your benchtops.
- **Any exposed edges or cutouts must be sealed prior to installation with a suitable water proofing sealant.**

If you have any questions, contact us on:
 Australia: **1800 666 078**
 Monday to Friday between 8:00am and 6:00pm AEST
 New Zealand: **0800 522 663**
 Monday to Friday between 8:00am and 5:00pm NZST
 or email: **info@kaboodlegroup.com.au**











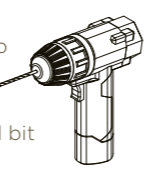
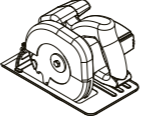

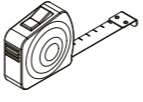
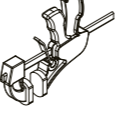
Hardware needed

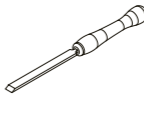
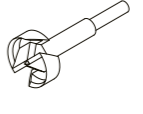
A  28mm wood screws	B  14mm wood screws	C  90° angle bracket
--	---	--

Note: Fixing hardware required is provided with the cabinets.

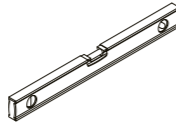
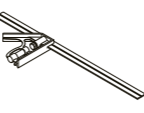
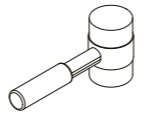
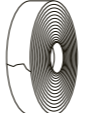
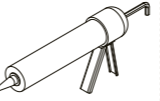
Tools you will need

To install your Kaboodle benchtops, you will need the following tools.

 Cordless drill with: • Number 2 screw tip • 4mm drill bit • Number 12 countersinking drill bit	 Circular saw	 Pencil	 Tape Measure	 Clamps (quick release)	 Personal protection equipment (ppe)	 Jigsaw	 10mm chisel	 30-40mm bore or spade bit	 Exterior wood glue (PVA)	 Contact adhesive	 Fine tooth wood saw
 Spirit level (900mm recommended)	 Adjustable square	 Rubber mallet	 Low adhesion masking tape	 Caulking gun	 10mm open end spanner	 Benchtop joiners	 50mm scraper				

cutting the benchtop

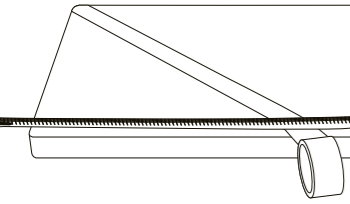
1. 

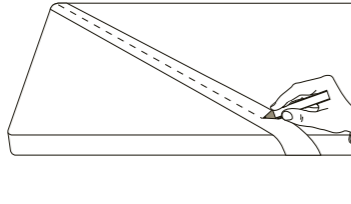
2. 

On the top of the benchtop, measure where you will be cutting your join on a 45 degree angle and apply low adhesion masking tape to the area that will be cut, also covering the edges. This will help prevent chipping and splintering when cutting the benchtop.

Turn the benchtop over so the underside is facing upwards and apply low adhesion masking tape to the area that will be cut. Use a straight edge and a 45 degree set square to determine your cut line and mark on top of the tape.

Note: If the walls adjoining your cabinetry are not perfectly square, it is still recommended to continue with a 45 degree join. Work required to straighten/level walls should be completed before the kitchen has been installed. However, once benchtops are joined, the back edges can be planed or trimmed slightly to suit. Tiles/splashbacks and silicone will hide small gaps and inconsistencies between walls and benchtops.

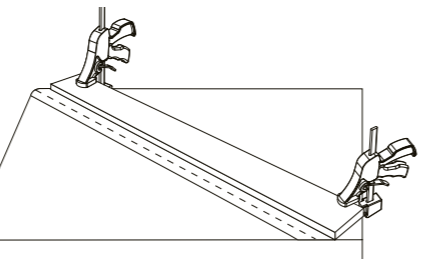
3. 

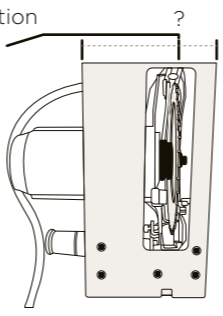

Clamp the straight edge parallel to the marked join line on the underside of the benchtop. To do this you will need to determine the correct position of the straight edge depending on the model and make of the chosen circular saw.

Work out the distance from the edge of the base plate to the blade of the tool. This measurement should be the same as the distance that you place the straight edge (or guide) from the cut line.

Note: To ensure you achieve a straight cut, you will require a straight edge (or a guide) to assist with cutting.

Tip: When clamping onto the benchtop ensure the clamps have soft jaws or suitable protection is placed on the surface of the benchtop to avoid damage.

cutting the benchtop

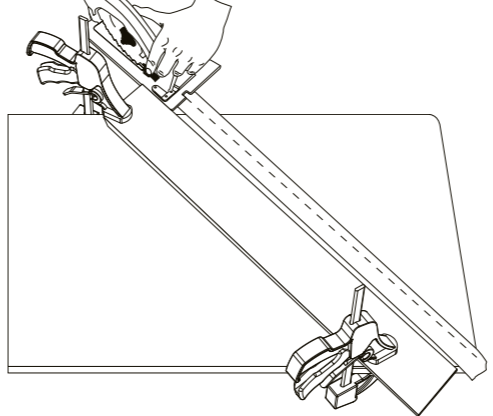
1. 

Important: It is recommended that you use the assistance of a second person to secure the benchtop and help support the off cut during the cutting process. Always use PPE when employing power tools and ensure all safety precautions have been taken.

Cut the benchtop with the circular saw making sure you keep the base of the saw against the straight edge. Repeat this process for the other benchtop joins.

Set the depth of the circular saw blade to approximately 10mm deeper than the thickness of your benchtop. The blade must be at a right angle to the base plate. This will provide a vertical cut.

Note: It is recommended that the saw blade enters from the front edge of the benchtop (the side that will be most visible once installed).

attaching edging

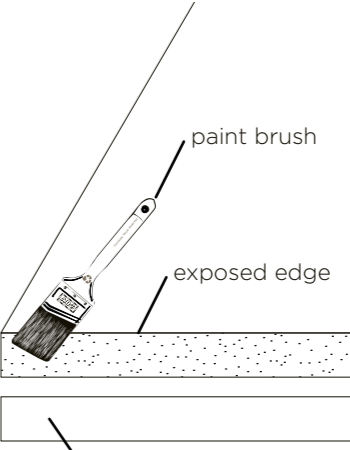
1. 

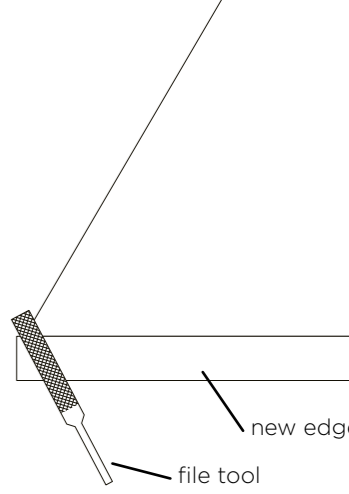
2. 

Using contact adhesive, attach the edging strip to the exposed end of the benchtop making sure there is overhang of the strip all the way around.

Once the edging has properly adhered, use a file to remove the excess edging from around the benchtop until it is even with the edge of the benchtops.

Note: Refer to the adhesive manufacturers guidelines for correct application.

Note: The edging is slightly larger than the benchtop to allow for filing down once it has been attached.

A	B	C
		
28mm wood screws	14mm wood screws	90° angle bracket

preparing for benchtop joins

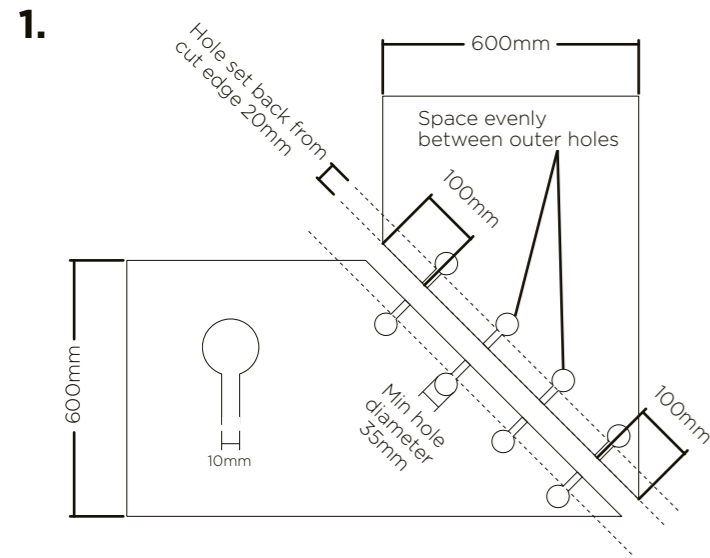

On the underside of the benchtop, measure and mark a straight line 20mm in from the cut edge. This line indicates the edge position of the bore holes for the joiners.

Measure and mark 100mm from the edge of each benchtop. Measure the space between the two marks and divide this by 3 to give you the positions of your other benchtop joiners.

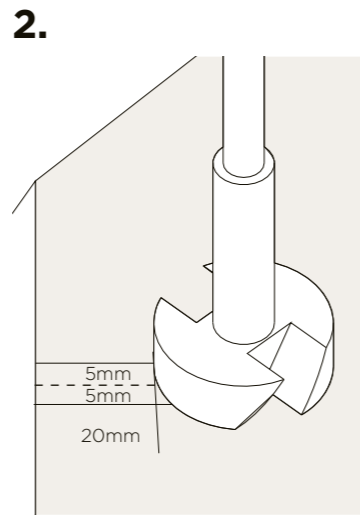

Using a 35mm hinge bore bit, drill to a depth of 17mm. Ensure the point of the bore bit will not protrude through the top of the benchtop. If this is likely to occur, reduce the planned depth of the hole.

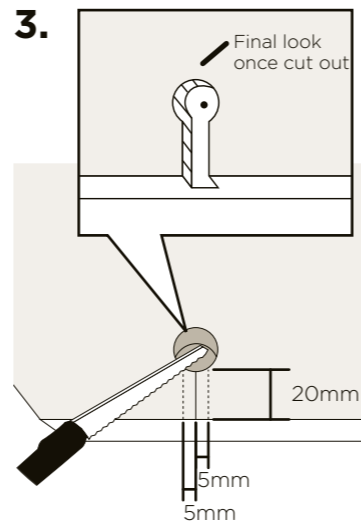

Using a fine tooth wood saw and a chisel, create a 10mm wide channel to join each opposing hole. The channel must be the same depth as the bore holes.

joining to cabinets

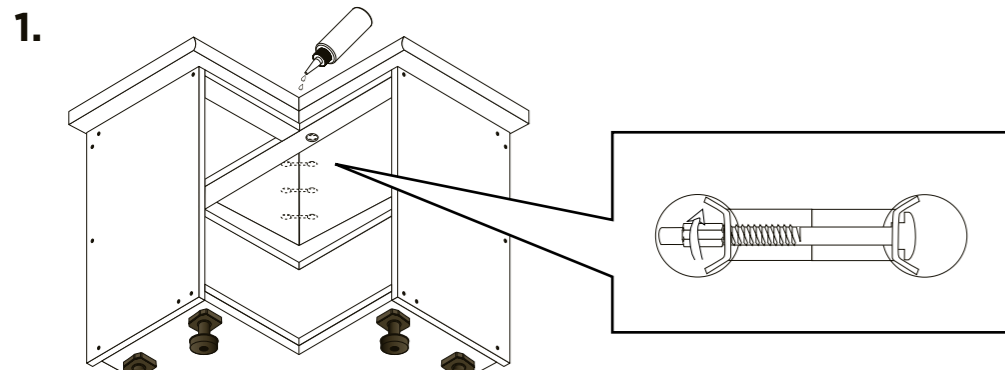

Hint: You may need to pull the benchtop forward slightly to work on the front joiner. Push it back into position when working on the remaining joiners. If this is not possible, drill a 50mm hole through the top rail of the cabinet to allow access to the joiners.

Tools Needed: biscuit joiner, saw, measuring tape, square, wood glue, spreading stick
The biscuit joiner is designed for cutting and joining. It provides an accurate, effective means of joining natural wood or manufactured benchtops. For proper usage, please refer to the manufacturer's instructions.

If your benchtops have been purchased with pre-cut biscuit slots please skip to step 4.

1. Mark location of the biscuits to be glued between benchtops. Ensure markings allow for even spacing between biscuits. As a general rule, biscuits should be equally

spaced between bore holes, with the first biscuit slot inserted between the front edge of the benchtop and the first bore hole.

2. Cut biscuit slots with the biscuit joiner (refer to manufacturer's instructions). Ensure the benchtop is properly secured, as considerable force is required to push the blade into the benchtop.

3. Remove any sawdust and debris from biscuit slots.

4. After cutting the biscuit slots, it is best to trial join biscuits to ensure proper fit before gluing.

Place the benchtops into position with the top sides facing upward. Liberally apply exterior wood working glue (PVA) to both faces of the joint, ensuring that both join faces are completely covered with glue. Do not use silicone.

Push the 2 pieces together, and starting from the front of the benchtop insert the joiners into the holes as shown in the diagram. Align the top and front edge of the benchtop to ensure that it is even and flush. Gently tighten the joiners until they hold into position with a 10mm open end spanner.

Tighten the benchtop joiners in succession so they are secure whilst ensuring the top of the benchtop remains flush. You may need to gently tap the top with a rubber mallet to achieve a flush join.

Note: Do not overtighten bench joiners. Overtightening may cause the benchtop to crack.

Remove any excess glue with a damp cloth.

installing benchtops

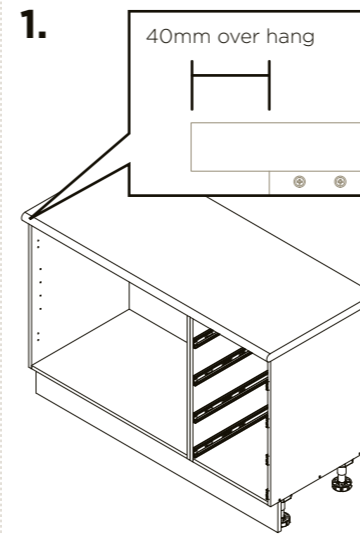

Measure the distance from the wall to the front of the cabinet at both ends of the run of cabinets. The benchtop may need to be trimmed if your wall is uneven.

The benchtop should protrude 40mm over the edge of the cabinet.

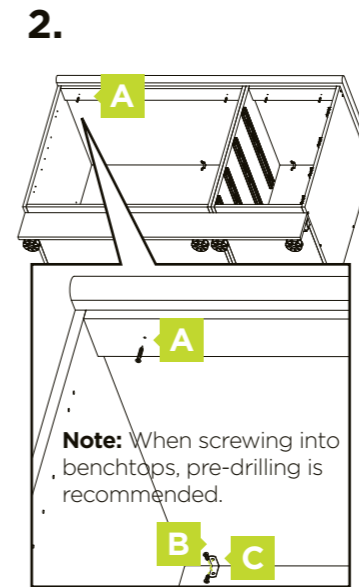

Note: When screwing into benchtops, pre-drilling is recommended.

For bamboo benchtops, drill an elongated hole on the front rail. This can be achieved by drilling 2x5mm holes side by side and using the drill in a swaying motion to join the holes. This will allow for natural expansion and contraction of the bamboo.

installing postform edged benchtops

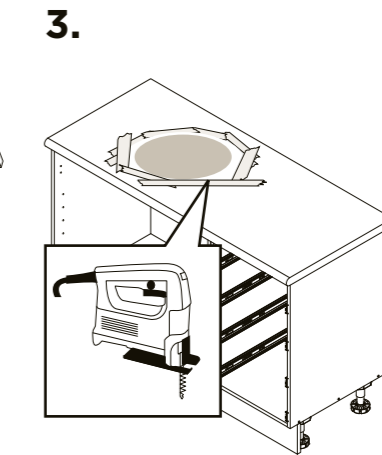

Measure and mark the cutouts for the appliances or sink using the manufacturers product specifications.

For bamboo benchtops, it is recommended that you apply your desired coating at this stage. It is important to sand and coat the inside edges of cutouts.

Tip: Apply low adhesive masking tape around the outside of the cutout to reduce benchtop splintering.

sealing edges

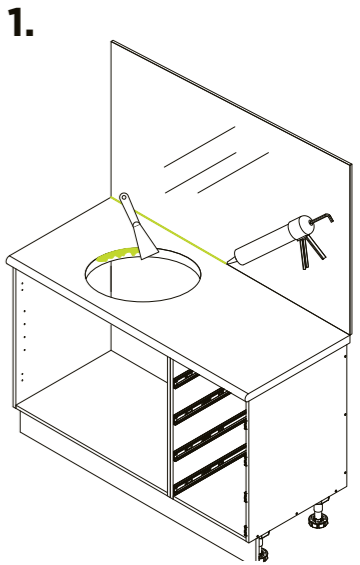

Any cut or exposed edges, like sink cutouts, must be sealed to prevent water penetrating and damaging the benchtop. Using a 50mm scraper, apply a layer of silicone over the area. Make sure the silicone is dry before the benchtop is installed.

Once the benchtop is installed, finish by apply a bead of silicone between the splashback and the benchtop.

Caring for your kaboodle benchtop

Looking after your benchtops is really easy and with the right care and maintenance they will last you for many years. Just follow these simple steps and if you need any more information you can contact us at: Australia: **1800 666 078** Monday to Friday between 8:00am and 6:00pm AEST. New Zealand: **0800 522 663** Monday to Friday between 8:00am and 5:00pm NZST or email: info@kaboodlegroup.com.au.

Laminate benchtops are very easy to keep clean and should be regularly wiped with a damp cloth or sponge using warm soapy water or an all purpose, non-abrasive cleaning product. Never use a saturated cloth or sponge, harsh chemicals or thinner based cleaners on your laminate benchtop. Avoid sharp objects that may cut, scratch or gauge the benchtop and never cut directly on the benchtop or put any hot pots or pans directly on the surface. If the laminate is severely damaged, avoid any moisture near the exposed area as liquids will damage the inside of the benchtop and it may swell.

We offer a dedicated customer service line for advice or any questions you may have on kaboodle products.

Call customer service on: Australia: **1800 666 078** Monday to Friday between 8:00am and 6:00pm AEST

New Zealand: **0800 522 663** Monday to Friday between 8:00am and 5:00pm NZST or email: info@kaboodlegroup.com.au

