

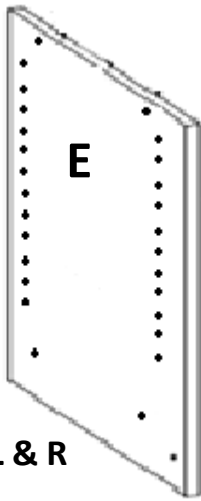

# MULTISTORE

## ASSEMBLY INSTRUCTION FOR LSD 330

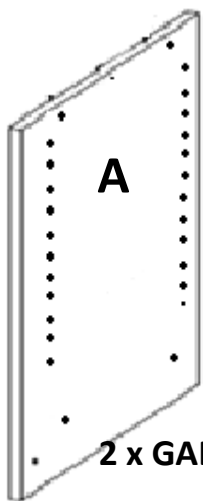

2 x GABLES L & R

1 x BOTTOM KICK



B



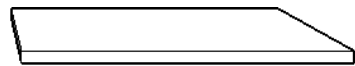



2 x FIXED SHELVES



C & D

1 x BACKING BOARD



NO	MODEL	DESCRIPTION	QTY
1		CONFIRMAT SCREWS 50mm x 5mm	10
2		CAPS	10
3		BACKING NAILS	45
4		16mm PAN HEAD UNIT WOOD SCREWS	1
5		25mm PAN HEAD WALL WOOD SCREWS	1
6		"L" SAFETY BRACKET	1



# MULTISTORE

## ASSEMBLY INSTRUCTION FOR LSD 330

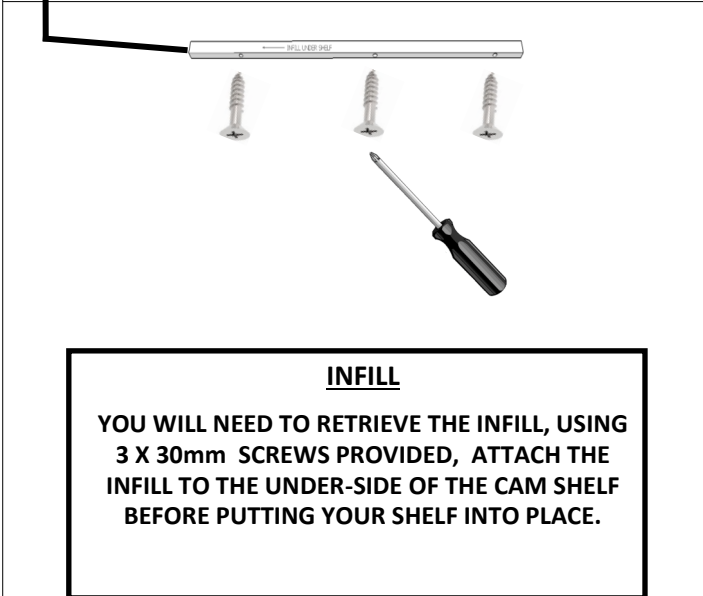
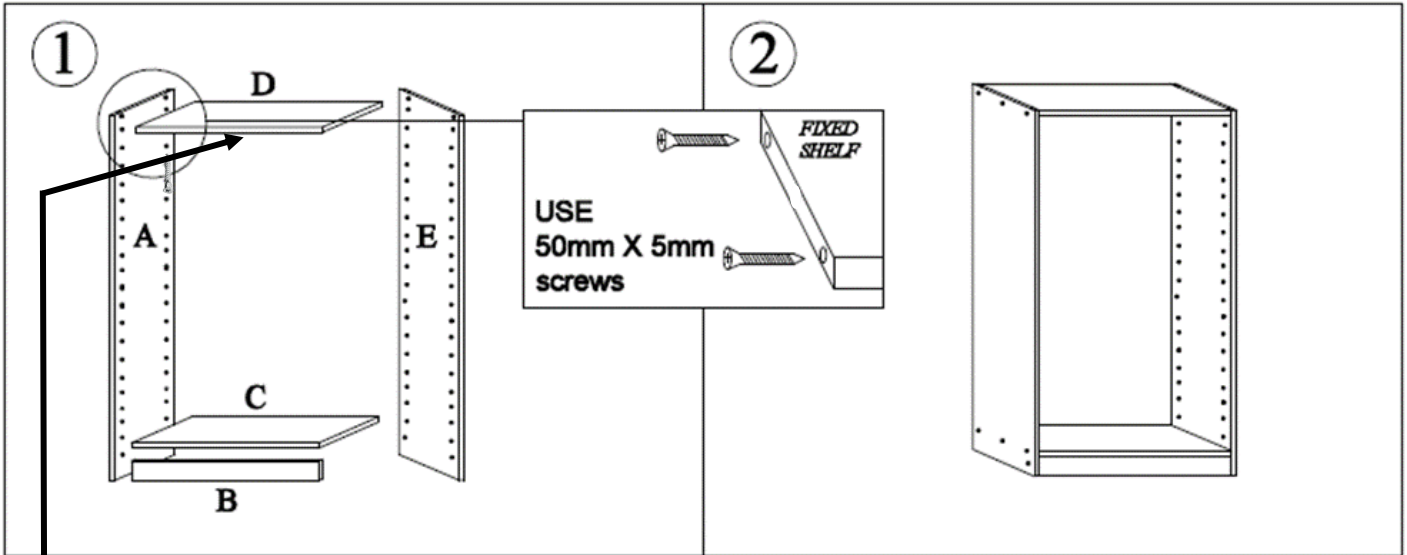

**WARNING:** Serious injury or death can be caused by toppling furniture

Help prevent tip-over:

- Anchor this product to a wall or other suitable surface
- Check anchors regularly
- Avoid placing TVs on top unless the TV is also anchored
- Use drawer locks to prevent children climbing

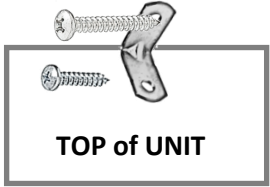

When attaching unit to wall put safety bracket in middle of unit with 16mm pan head screw then 25mm pan head screw into wall. For plaster-board without a stud it is recommended to use a plug with screw (not provided).



## 1 x DRAWER ASSEMBLY INSTRUCTION

NO	MODEL	DESCRIPTION	QTY
1		CONFIRMAT SCREWS	4
2		DOWELS	4
3		BACKING NAILS	20
4		5/8 X 6 WOOD SCREWS	6
5		INFILL	1

NO	MODEL	DESCRIPTION	QTY
6		CAMS	2
7		CAM PINS	2
8		30mm 8 GAUGE SCREW	3
9		EURO SCREWS	4
10		HANDLE	1
11		RUNNERS PER SET	1

### STEP 1.

LAYOUT YOUR DRAWER PIECES FLAT AS PER DESIGN WITH PRE-DRILLED HOLES FACING UP.

START WITH THE BACK OF THE FRONT DRAWER AND PLACE YOUR DOWELS & CAM PIN IN THE PRE-DRILLED HOLES ON EITHER SIDE AS INSTRUCTED BELOW.

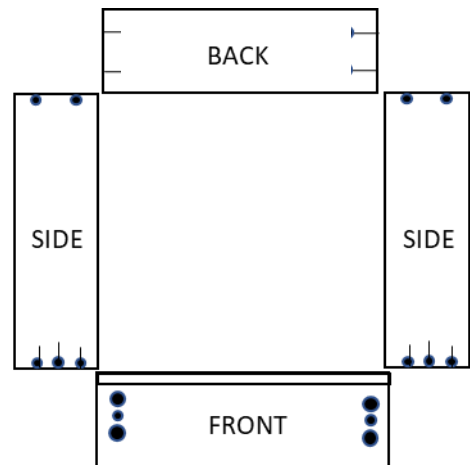
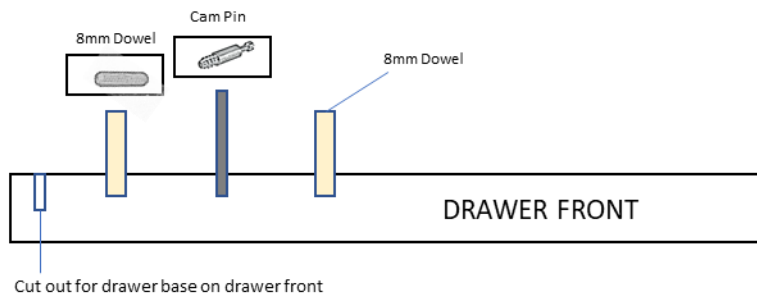

### STEP 2.

GRAB YOUR FIRST SIDE AND INSERT YOUR CAMS INTO THE HOLE PROVIDED ON THE OUTSIDE OF THE DRAWER SIDE GENTLY AS PER INSTRUCTIONS BELOW.

IMPORTANT NOTICE:



PLACE THE FITTING OVER THE HOLE KEEPING THE SQUARE EDGE OF THE FITTING PARALLEL TO THE FACE OF THE BOARD, KNOCK IN **CAREFULLY**.

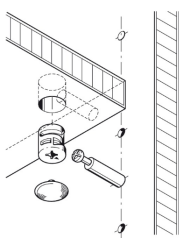

PUSH THE SIDE INTO THE FRONT DOWELS & PIN AND THEN CAREFULLY USING A SCREW DRIVER TURN UNTIL IT LOCKS IN. REPEAT THIS PROCESS WITH THE OTHER SIDE.

NOW PLACE YOUR LAST PIECE BETWEEN THE TWO SIDES USING THE SCREWS SUPPLIED SCREW INTO THE SIDES OF THE BACK DRAWER PIECE.



## DRAWER ASSEMBLY

### STEP 3.

YOUR DRAWER SHOULD BE FACING DOWN WITH THE FRONT DRAWER EXPOSING THE CUTOUT FOR THE BASE TO BE PUSHED INTO FACE DOWN WITH THE BROWN SIDE SHOWING. MAKING SURE YOU HAVE THE DRAWER SQUARE, PROCEED TO NAIL DOWN THE BASE SPACING THEM OUT AROUND THE EDGE OF THE THREE SIDES.

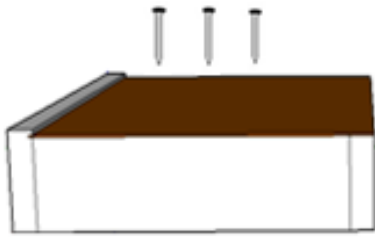

### STEP 4.

#### RUNNER PLACEMENT

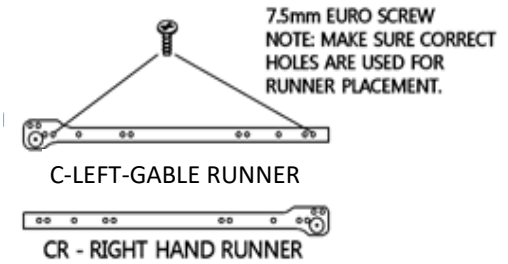

PLACE YOUR RUNNERS INTO THE DESIGNATED HOLES MAKING SURE THE WHEEL IS FACING TO THE FRONT OF THE GABLE. **HOLE POSITION NO 1, .**

YOUR DRAWER RUNNER WILL HAVE THE WHEEL TO THE BACK OF THE DRAWER.

### STEP 5.

USING THE HANDLE SCREW (NO:5) ATTACH THE HANDLE TO THE BACK OF THE DRAWER FRONT INTO THE PREDRILLED HOLES ALREADY PROVIDED.

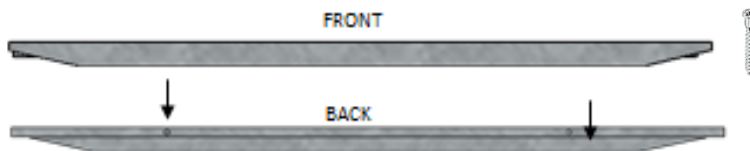

### STEP 6.

PLACE YOUR DRAWER RUNNER ON THE BOTTOM OF THE DRAWER USING THE WOOD SCREWS PROVIDED (No:4) SCREW TWO INTO EACH RUNNER . REPEAT FOR THE OTHER SIDE.

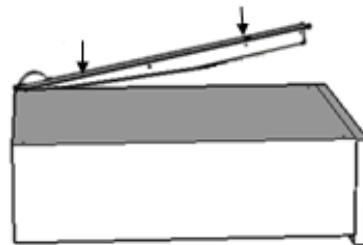

### PICTURE OF YOUR FINISHED DRAWER



Multistore Industries (Aust) Pty Ltd

9 Nevilles Street, Underwood, QLD 4119

Tel—(07) 3208 6799

Fax- (07) 3209 6332

[www.multistore.com.au](http://www.multistore.com.au)

[sales@multistore.com.au](mailto:sales@multistore.com.au)