

# RYOBI®

ORIGINAL INSTRUCTIONS

## Cordless Blower

RBL365J  
RBL3601J  
RBL3651J



## **Important!**

It is essential that you read the instructions in this manual before assembling, operating, and maintaining the product.

Subject to technical modification.

Safety, performance, and dependability have been given top priority in the design of your cordless blower.

### INTENDED USE

The cordless blower is only intended for use outdoors in dry and well-illuminated conditions.

The product is not intended to be used by children or persons with reduced physical, mental, or sensory capabilities.

The product is designed for blowing light debris, such as leaves, grass, and other garden refuse.

Do not use the product for any other purpose.

### GENERAL SAFETY WARNINGS

#### ⚠ WARNING

**Read all safety warnings and all instructions.** Failure to follow the warnings and instructions may result in electric shock, fire, and/or serious injury. Save all warnings and instructions for future reference.

#### ⚠ WARNING

Never allow children, persons with reduced physical, sensory or mental capabilities or lack of experience and knowledge, or people unfamiliar with these instructions to use the product. Local regulations may restrict the age of the operator.

### TRAINING

- Read the instructions carefully. Be familiar with the controls and the correct use of the product.
- Keep in mind that the operator or user is responsible for accidents or hazards occurring to other people or their property.
- Never use the product when you are tired, ill, or under the influence of alcohol, drugs, or medicine.

### PREPARATION

- Some regions have regulations that restrict the use of the product to some operations. Check with your local authority for advice.
- Wear hearing protection at all times while operating the product. The product is noisy,

and permanent hearing injury may result if precautions to limit your exposure, reduce noise, and wear hearing protection are not strictly adhered to.

- Wear full eye protection at all times while operating the product. The manufacturer strongly suggests a full face mask or fully enclosed goggles. Normal spectacles or sunglasses are not adequate protection. Objects can be thrown at high speed by the powerful air jet at any time and may rebound from hard surfaces toward the operator.
- While operating the product, always wear substantial footwear and long trousers. Do not operate the product when barefoot or wearing open sandals. Avoid wearing clothing with loose fitting or that has hanging cords or ties.
- Do not wear loose clothing or jewellery that can be drawn into the air inlet. Secure long hair so it is above shoulder level to prevent entanglement in moving parts.
- Before each use, ensure that all controls and safety devices function correctly. Do not use the product if the off switch does not stop the product.
- Operate the product in a recommended position and only on a firm and level surface.
- Do not operate the product on a paved or gravel surface where ejected material could cause injury.
- Before each use, always inspect the housing for damage. Ensure that guards and handles are in place and properly secured. Replace worn or damaged components in sets to preserve balance. Replace damaged or unreadable labels.
- Never operate the product while people, especially children, or pets are nearby.
- Keep all cooling air inlets clear of debris.
- Use rakes and brooms to loosen debris before blowing.
- Clear the work area before each use. Remove all objects such as rocks, broken glass, nails, wire, or string that can be blown a considerable distance by high velocity air.

### BATTERY TOOL USE AND CARE

- Recharge only with the charger specified by the manufacturer. A charger that is

suitable for one type of battery pack may create a risk of fire when used with another battery pack.

- Use power tools only with specifically designated battery packs. Use of any other battery packs may create a risk of injury and fire.
- When battery pack is not in use, keep it away from other metal objects, like paper clips, coins, keys, nails, screws or other small metal objects that can make a connection from one terminal to another. Shorting the battery pack terminals together may cause burns or a fire.
- Under abusive conditions, liquid may be ejected from the battery pack; avoid contact. If contact accidentally occurs, flush with water. If liquid contacts eyes, additionally seek medical help. Liquid ejected from the battery pack may cause irritation or burns.
- Do not use a battery pack or tool that is damaged or modified. Damaged or modified batteries may exhibit unpredictable behaviour resulting in fire, explosion, or risk of injury.
- Do not expose a battery pack or tool to fire or excessive temperatures. Exposure to fire or excessive temperature above 130°C may cause explosion.
- Follow all charging instructions and do not charge the battery pack or tool outside the temperature range specified in the instructions. Charging improperly or at temperatures outside the specified range may damage the battery and increase the risk of fire.

## OPERATION

- Operate the product only at reasonable hours – not early in the morning or late at night when people might be disturbed.
- Never operate the product in an explosive atmosphere.
- Avoid using the product in bad weather conditions especially when there is a risk of lightning.
- Keep bystanders, children and pets 15 m away from the area of operation. Stop the product if anyone enters the area.
- Do not operate in poor lighting. The operator requires a clear view of the work area to identify potential hazards.

- Operating similar tools nearby increases both the risk of hearing injury and the potential for other persons to enter your working area.
- Always be sure of your footing on slopes. Walk, never run.
- Keep proper footing and balance. Do not overreach. Overreaching can result in loss of balance.
- Never use the product with defective guards or shields, or without safety devices in place.
- Do not modify the product in any way or use parts and accessories that are not recommended by the manufacturer.

### **⚠ WARNING**

If the product is dropped, suffers heavy impact, or begins to vibrate abnormally, immediately stop the product and inspect for damage or identify the cause of the vibration. Any damage should be properly repaired or replaced by an authorised service centre.

- To reduce the risk of injury associated with contacting rotating parts, always stop the product and remove the battery pack. Make sure all moving parts have come to a complete stop before:
  - leaving the product unattended
  - clearing blockages
  - checking, cleaning, or working on the product
  - inspecting the product after striking a foreign object
- Immediately switch off and remove the battery pack in the event of accident or breakdown. Do not operate the product again until it has been fully checked by an authorised service centre.

### **⚠ WARNING**

Your blower may be supplied with a harness. Carefully adjust the harness to comfortably help you in supporting the weight of the product.

Identify the quick release mechanism and practice using it before you start using the product. Its correct use may prevent serious injury in the case of an emergency. Never wear additional clothing over the harness or otherwise restrict access to the quick release mechanism.

### **BLOWER SAFETY WARNINGS**

- Wear a face filter mask in dusty conditions to reduce the risk of injury associated with the inhalation of dust.
- Slightly dampen surfaces in dusty conditions.
- Do not use the product near open windows.
- Use the full blower nozzle extension so that the air stream can work close to the ground and perform effectively.
- Do not point the blower nozzle in the direction of people or pets.
- Never place objects inside the blower tubes.
- Do not place the product on top of or near loose debris. Debris can be sucked into the intake vent, resulting in possible damage to the product.

### **ADDITIONAL BATTERY SAFETY WARNINGS**

#### **⚠ WARNING**

To reduce the risk of fire, personal injury, and product damage due to a short circuit, never immerse your tool, battery pack or charger in fluid or allow a fluid to flow inside them. Corrosive or conductive fluids, such as seawater, certain industrial chemicals, and bleach or bleach-containing products, etc., can cause a short circuit.

### **TRANSPORTATION AND STORAGE**

- Stop the product, remove the battery pack, and allow it to cool down before storing or transporting.

- Clean all foreign materials from the product. Store the product in a cool, dry, and well-ventilated place that is inaccessible to children. Keep away from corrosive agents, such as garden chemicals and de-icing salts. Do not store outdoors.
- For transportation in a vehicle, secure the product against movement or falling to prevent injury to persons or damage to the product.

### **TRANSPORTING LITHIUM BATTERIES**

Transport the battery pack in accordance with local and national provisions and regulations.

Follow all special requirements on packaging and labelling when transporting batteries by a third party. Ensure that no batteries can come in contact with other batteries or conductive materials while in transport by protecting exposed connectors with insulating, non-conductive caps or tape. Do not transport battery packs that are cracked or leaking. Check with the forwarding company for further advice.

### **MAINTENANCE**

#### **⚠ WARNING**

Use only original manufacturer's replacement parts, accessories, and attachments. Failure to do so can cause possible injury and poor performance, and may void your warranty.

#### **⚠ WARNING**

Servicing requires extreme care and knowledge and should be performed only by a qualified service technician. For service, bring the product to an authorised service centre. When servicing, use only original replacement parts.

- Do not make adjustments and repairs not described in this manual. For other repairs, contact an authorised service centre.
- After each use, clean the product with a soft, dry cloth.
- Check all nuts, bolts, and screws at frequent intervals for proper tightness to ensure that the product is in safe working condition. Any part that is damaged should be properly repaired or replaced by an authorised service centre.

- Bring the product to an authorised service centre to replace damaged or unreadable labels.

### CLEARING A BLOCKAGE

- To reduce the risk of injury associated with contacting rotating parts, always stop the product, remove the battery pack, and make sure all moving parts have come to a complete stop.
- Remove the blower tubes to inspect for blockage. Clear the tubes if required.
- Re-install the blower tubes before starting the product.

### RESIDUAL RISKS

Even when the product is used as prescribed, it is still impossible to completely eliminate certain residual risk factors. The following hazards may arise in use, and the operator should pay special attention to avoid the following:

- Injury caused by vibration
  - Always use the right tool for the job and use designated handles.
  - Hearing injury caused by exposure to noise
  - Wear ear protection and limit exposure.
- Injury from flying objects from the blower tube airflow
  - Wear eye protection at all times.

### RISK REDUCTION

It has been reported that vibrations from handheld tools may contribute to a condition called Raynaud's Syndrome. Symptoms may include tingling, numbness, and blanching of the fingers, usually apparent upon exposure to cold. Hereditary factors, exposure to cold and dampness, diet, smoking, and work practices are all thought to contribute to the development of these symptoms. There are measures that can be taken by the operator to possibly reduce the effects of vibration:

- Keep your body warm in cold weather. When operating the product, wear gloves to keep the hands and wrists warm.
- After each period of operation, exercise to increase blood circulation.
- Take frequent work breaks. Limit the amount of exposure per day.

If you experience any of the symptoms of this condition, immediately discontinue use and see your physician.

### ⚠ WARNING

Injuries may be caused or aggravated by prolonged use of a tool. When using any tool for prolonged periods, ensure you take regular breaks.

### WHAT'S IN THE BOX

- Blower x 1
- Blower tube x 1
- Charger x 1
- Battery x 1
- Operator's manual x 1

**NOTE:** For RBL3601J, the battery and charger are sold separately.

### SYMBOLS ON THE PRODUCT



Read and understand all instructions before operating the product, follow all warnings and safety instructions.



Do not expose to rain or damp condition.



Wear ear protection.



Wear eye protection.



Beware of thrown or flying objects. Keep all bystanders at least 15 m away.



Rotating Fans. Keep hands and feet out of the openings while the product is running.



Remove the battery before starting any work on the product.



The guaranteed sound pressure level is 87 dB. The guaranteed sound power level is 101 dB.



Regulatory Compliance Mark (RCM). This product meets applicable regulatory requirements.



Waste electrical products should not be disposed of with household waste. Please recycle where facilities exist. Check with your Local Authority or retailer for recycling advice.

### SYMBOLS IN THIS MANUAL



Note



Warning



Parts or accessories are sold separately

The following signal words and meanings are intended to explain the levels of risk associated with this product.

#### **DANGER**

Indicates an imminently hazardous situation, which, if not avoided, will result in death or serious injury.

#### **WARNING**

Indicates a potentially hazardous situation, which, if not avoided, could result in death or serious injury.

#### **CAUTION**

Indicates a potentially hazardous situation, which, if not avoided, may result in minor or moderate injury.

#### **CAUTION**

Without safety alert symbol  
Indicates a situation that may result in property damage

WHAT'S IN THE BOX

RBL3651J

RBL365J

\* Kit includes battery and charger.

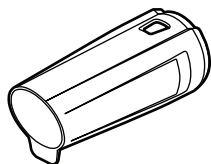

x 1

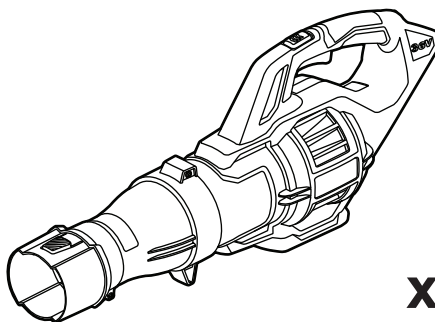

x 1

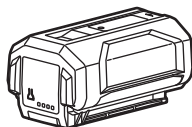

x 1



x 1



x 1

RBL3601J

\* Battery and charger are sold separately.

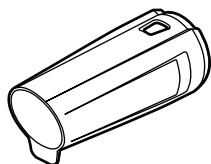

x 1

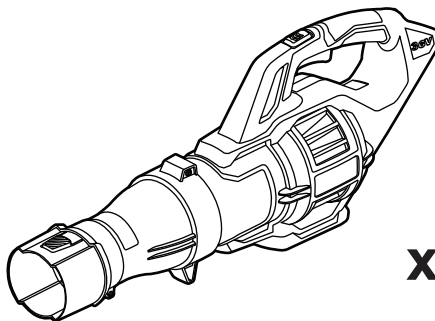

x 1



x 1

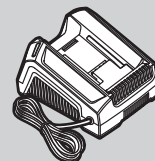
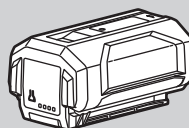



## KNOW YOUR PRODUCT

1. Turbo boost button
2. Switch trigger
3. Air inlet port
4. Charger
5. Battery pack

6. Battery latch button
7. Blower tube
8. Blower housing
9. Tube latch

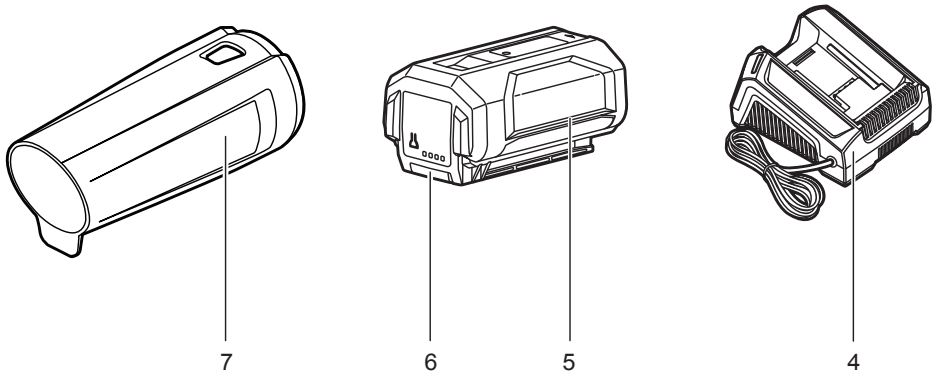
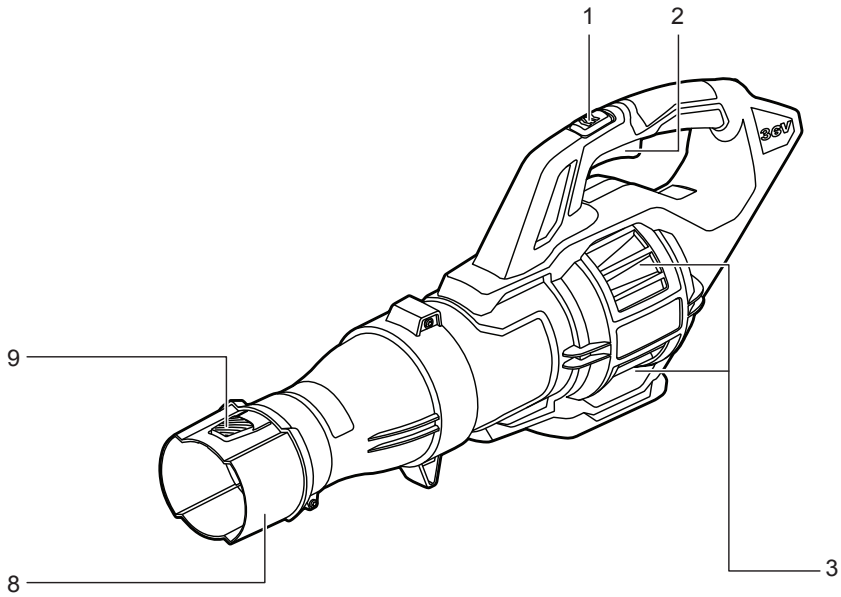

GETTING STARTED

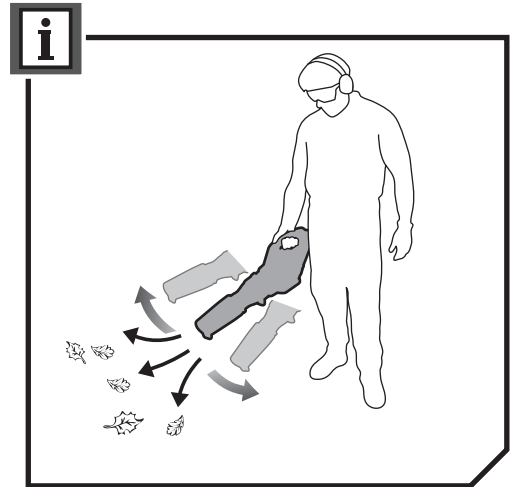
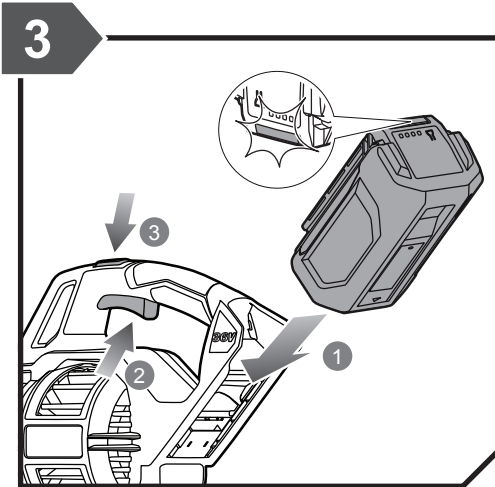
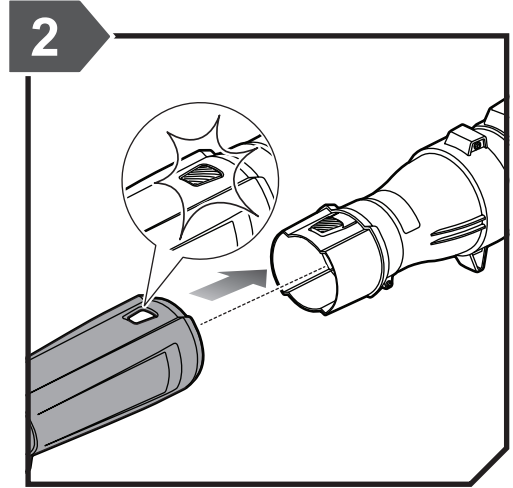
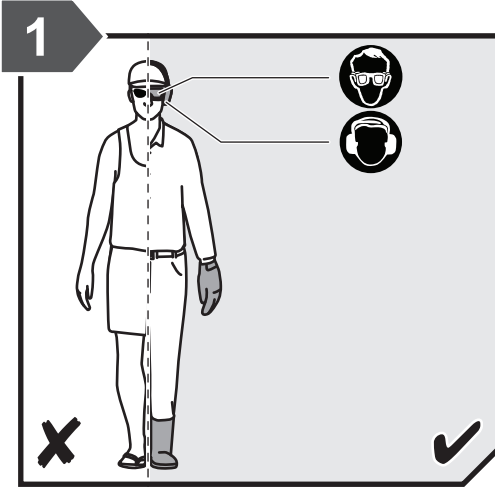

# OVERVIEW

## OPERATION

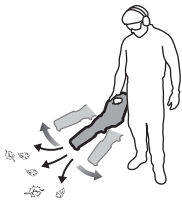

p.10

## MAINTENANCE

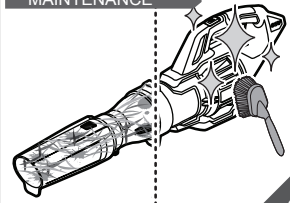

p.11

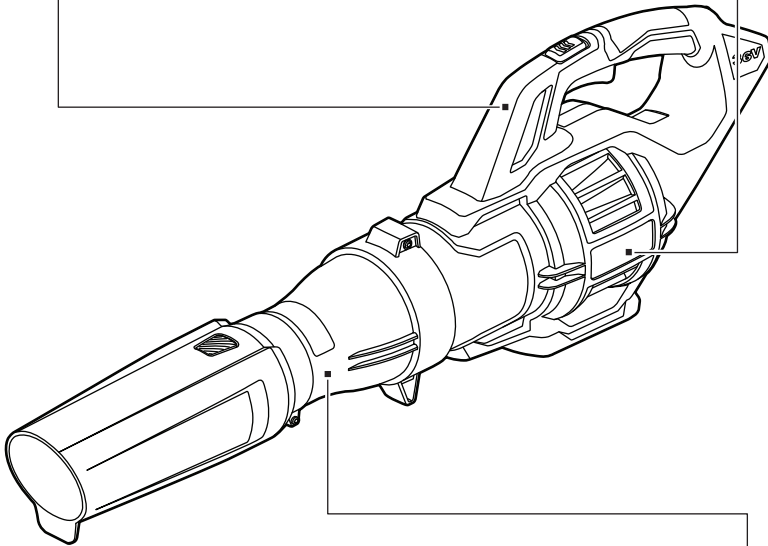

## STORAGE



p.12

# OPERATION

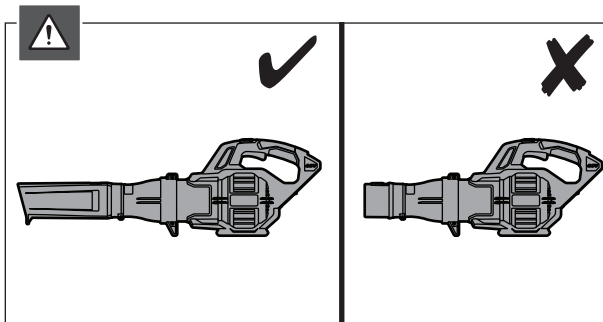
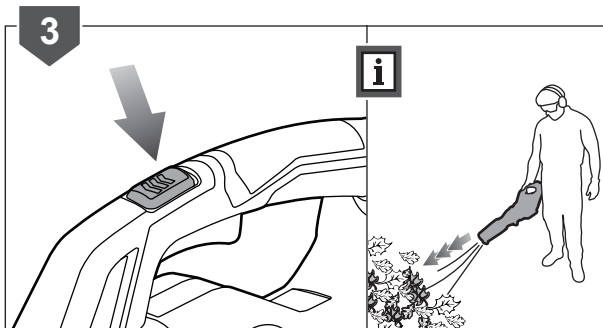
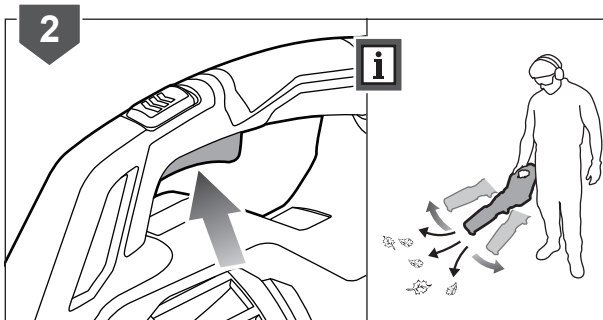
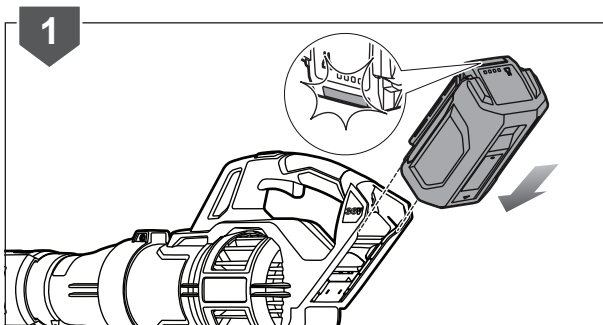
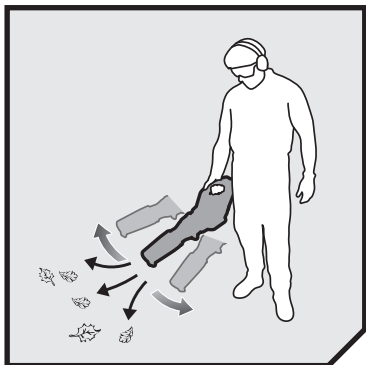

# MAINTENANCE

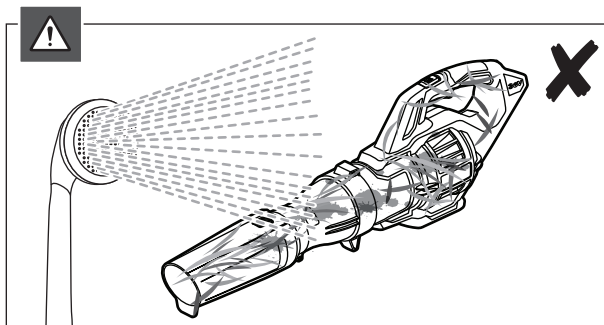
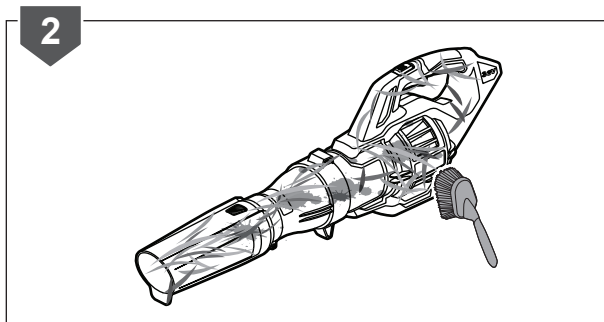
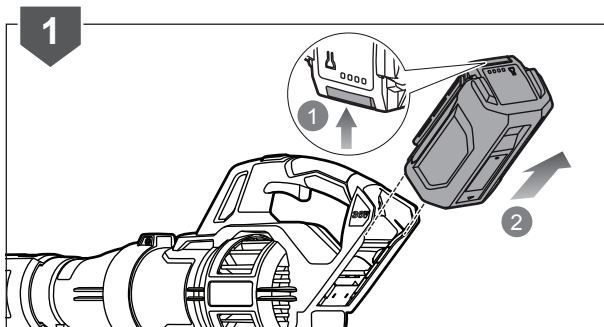
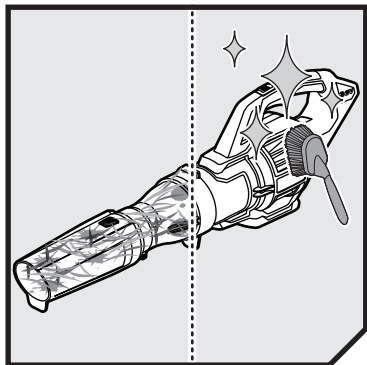

# STORAGE

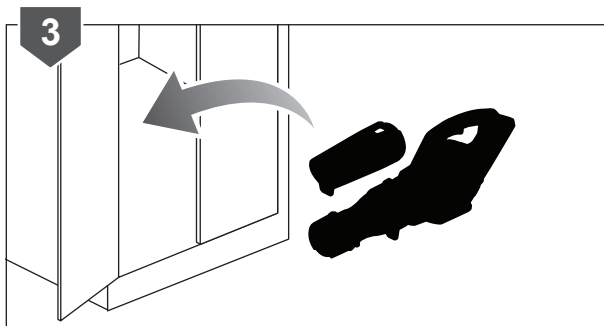
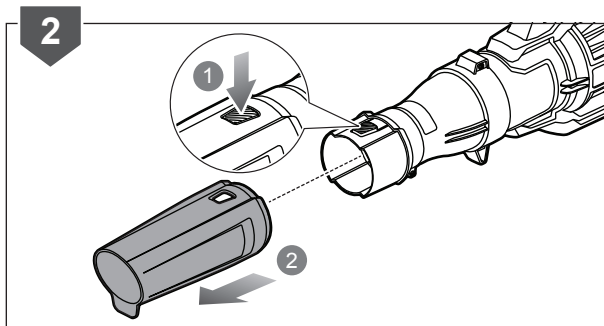
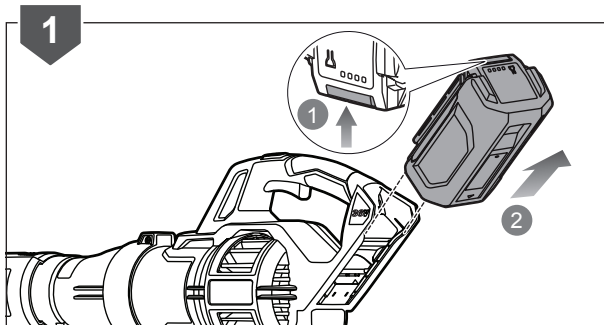
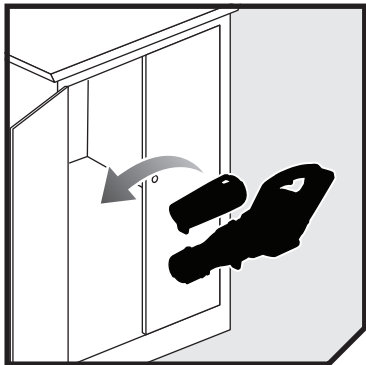

## PRODUCT SPECIFICATIONS

### Cordless Blower

|   |                               |
|---|-------------------------------|
| Model   | RBL365J/RBL3601J/<br>RBL3651J |
| Rated voltage   | 36 V                          |
| Rated current   | 16.0 A                        |
| Air Velocity  | 160 km/h                      |
| Air Volume  | 450CFM                        |
| Weight<br>(without battery)   | 3.07 kg                       |
| Weight<br>(with heaviest battery)   | 4.48 kg                       |
| Vibration level (in accordance with Annex BB of EN 50636-2-100:2014)      |                               |
| Vibration total value   | 4.4 m/s <sup>2</sup>          |
| Uncertainty of measurement  | 1.5 m/s <sup>2</sup>          |
| Noise emission level (in accordance with Annex CC of EN 50636-2-100:2014) |                               |
| A-weighted sound pressure level<br>at the operator's position             | 83.60 dB(A)                   |
| Uncertainty of measurement  | 3 dB(A)                       |
| A-weighted sound power level  | 99.93 dB(A)                   |
| Uncertainty of measurement  | 0.53 dB(A)                    |

## BATTERY AND CHARGER

| Model                   | RBL365J   | RBL3601J     | RBL3651J |
|-------------------------|---|--------------|----------|
| Battery pack            | BPL3650D2   | Not included | BPL3650D |
| Charger                 | BCL3620S  | Not included | BCL3620S |
| Compatible battery pack | BPL3615, BPL3626, BPL3626D, BPL3626D2, BPL3640, BPL3640D, BPL3650D, BPL3650D2 |              |          |
| Compatible charger      | BCL3620, BCL3620S, BCL3650F   |              |          |

## VIBRATION LEVEL

### WARNING

The declared vibration value has been measured with a standard test method and may be used to compare one tool with another.

The declared vibration value may be used in a preliminary assessment of exposure.

The vibration emission during actual use of power tool can differ from the declared total value depending on the ways in which the tool is used.

Identify safety measures to protect yourself based on an estimation of exposure in the actual conditions of use, taking account of all parts of the operating cycle such as the times when the tool is switched off and when it is running idle in addition to the trigger time.



Imported by:

**Techtronic Industries Australia Pty Ltd**  
31 Gilby Road, Mount Waverley, VIC 3149  
Melbourne, Australia

**Techtronic Industries N.Z. Limited**  
2 Landing Drive, Mangere  
Auckland, 2022, New Zealand

961087026-01