

ozito

DRILL PRESS

500W 9 Speed

INSTRUCTION MANUAL

SPECIFICATIONS

Motor Size:	500W (S2 15min)
Input:	230 – 240V ~ 50Hz
No Load Speed:	500-2,500/min
Chuck:	16mm Keyed
Morse Taper:	B16-2MT
Spindle Travel:	50mm
Spindle Shaft to Column Distance:	115mm
Column Height:	625mm
Table Size:	168x168mm
Table Tilt:	0-45° (Left & Right)
Weight:	16.08kg

ozito.com.au

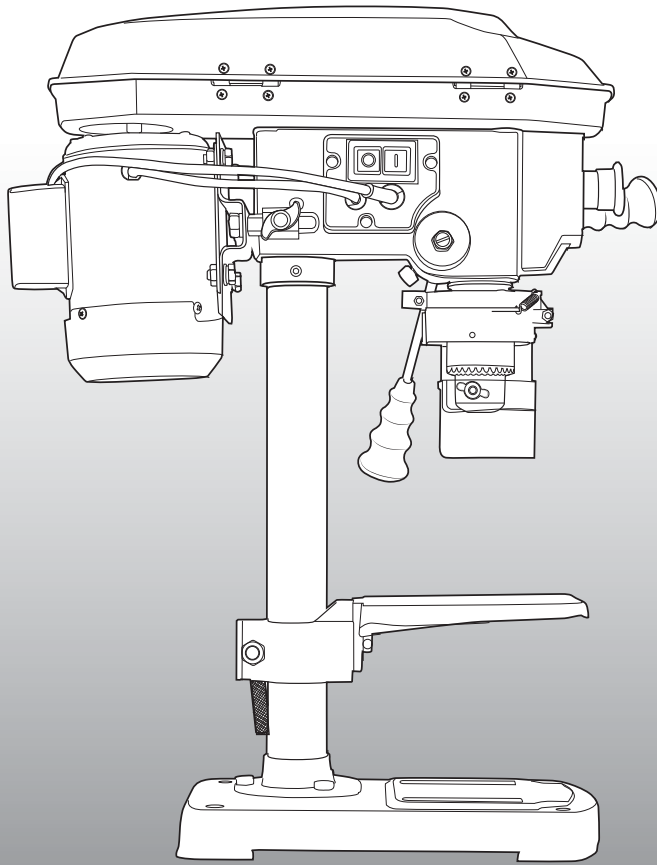

STANDARD EQUIPMENT

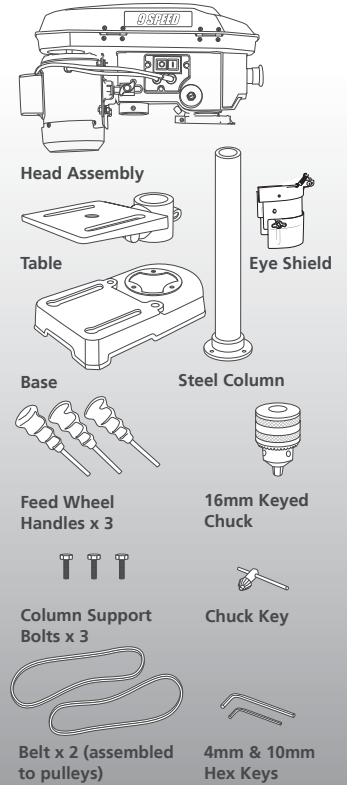

3 YEAR REPLACEMENT WARRANTY

BDP-500

WARRANTY

IN ORDER TO MAKE A CLAIM UNDER THIS WARRANTY YOU MUST RETURN THE PRODUCT TO YOUR NEAREST BUNNINGS WAREHOUSE WITH YOUR BUNNINGS REGISTER RECEIPT. PRIOR TO RETURNING YOUR PRODUCT FOR WARRANTY PLEASE TELEPHONE OUR CUSTOMER SERVICE HELPLINE:

Australia 1800 069 486

New Zealand 0508 069 486

TO ENSURE A SPEEDY RESPONSE PLEASE HAVE THE MODEL NUMBER AND DATE OF PURCHASE AVAILABLE. A CUSTOMER SERVICE REPRESENTATIVE WILL TAKE YOUR CALL AND ANSWER ANY QUESTIONS YOU MAY HAVE RELATING TO THE WARRANTY POLICY OR PROCEDURE.

The benefits provided under this warranty are in addition to other rights and remedies which are available to you at law. Our goods come with guarantees that cannot be excluded at law. You are entitled to a replacement or refund for a major failure and for compensation for any other reasonably foreseeable loss or damage. You are also entitled to have the goods repaired or replaced if the goods fail to be of acceptable quality and the failure does not amount to a major failure.

Generally you will be responsible for all costs associated with a claim under this warranty, however, where you have suffered any additional direct loss as a result of a defective product you may be able to claim such expenses by contacting our customer service helpline above.

3 YEAR REPLACEMENT WARRANTY

Your product is guaranteed for a period of 36 months from the original date of purchase and is intended for DIY (Do It Yourself) use only. If a product is defective it will be replaced in accordance with the terms of this warranty. Warranty excludes consumable parts, for example: feed wheel handles, keyed chuck, hex key, chuck key, belt.

WARNING

The following actions will result in the warranty being void.

- If the tool has been operated on a supply voltage other than that specified on the tool.
- If the tool shows signs of damage or defects caused by or resulting from abuse, accidents or alterations.
- Failure to perform maintenance as set out within the instruction manual.
- If the tool is disassembled or tampered with in any way.
- Professional, industrial or high frequency use.

KNOW YOUR PRODUCT

DRILL PRESS

- | | |
|--------------------------|------------------------------|
| 1. Emergency Stop Button | 11. Table support lock |
| 2. Pulley cover screw | 12. Column support bolts x 3 |
| 3. Feed wheel handles | 13. Column support |
| 4. Belt tension knob | 14. Base |
| 5. Feed wheel hub | 15. Head assembly |
| 6. Column | 16. Depth indicator |
| 7. 16mm Keyed chuck | 17. ON/OFF Switch |
| 8. Eye Shield | 18. Head lock screw |
| 9. Table | 19. Chuck Key Holder |
| 10. Table support | |

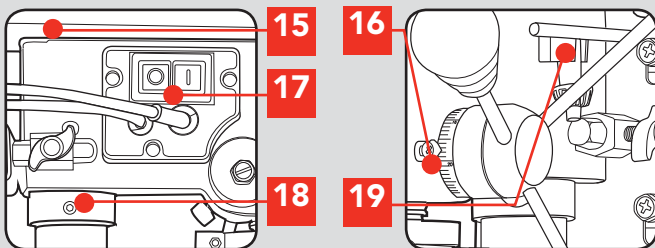
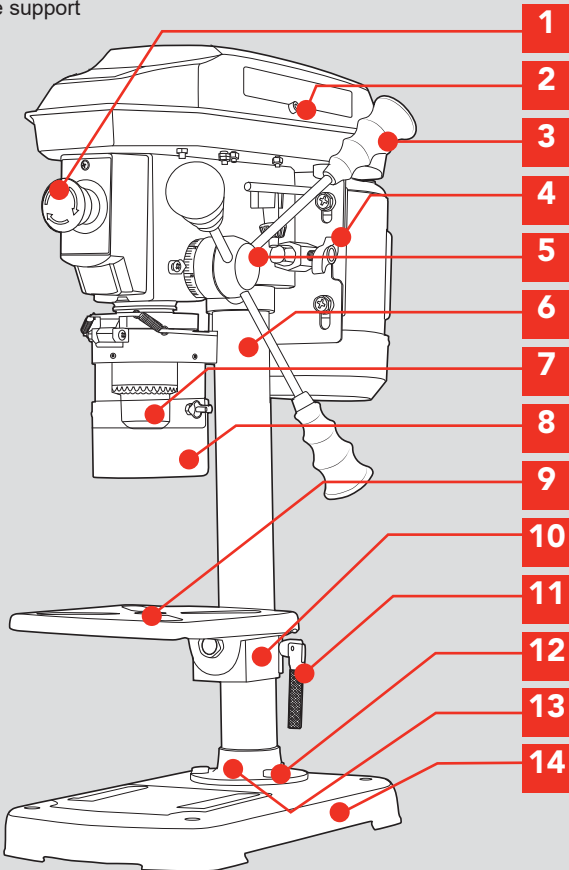

ACCESSORIES

- 20. Chuck key
- 21. 4mm & 10mm Hex key

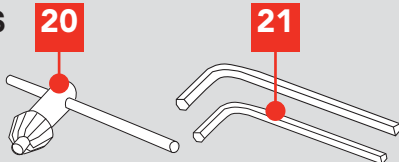

ONLINE MANUAL

Scan this QR Code with your mobile device to take you to the online manual.



SETUP & PREPARATION

1. ASSEMBLY

WARNING! DURING ASSEMBLY ENSURE THE DRILL PRESS IS DISCONNECTED FROM THE POWER SUPPLY.

Assembling the drill press

1. Carefully remove contents from the packaging.
2. Select a firm, level surface on which to assemble the drill press.
3. Place the base and align the column over the large hole. Align the holes in the column support with those in the base and secure in place using the 3 column support bolts (supplied). Using a 14mm spanner securely tighten all 3 column support bolts.

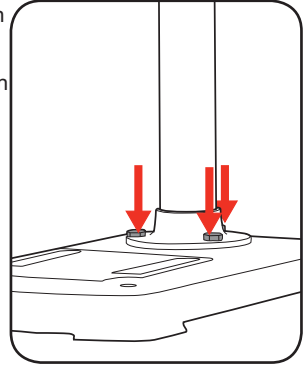

4. Slide the table support over the column. Using the table support lock, secure the table into the desired position.

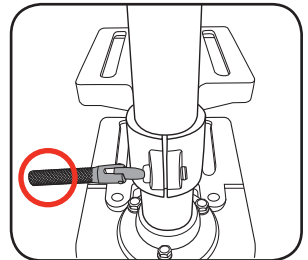

5. Lift the head assembly and slide it down onto the column as far as it will go. Rotate the head so that is aligned with the base. To secure in position install the 2 head lock screws. Tighten using the 4mm Hex key, rotating in a clockwise direction.

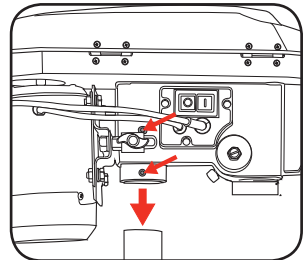

3 YEAR REPLACEMENT WARRANTY

6. To fit the eye shield, first loosen the phillips head screw on the shield and then slide over the drill spindle. Tighten the securing screw to lock in position.

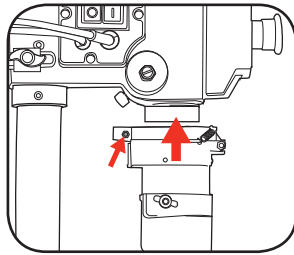

7. To fit the feed wheel handles, screw them into the feed wheel hub.

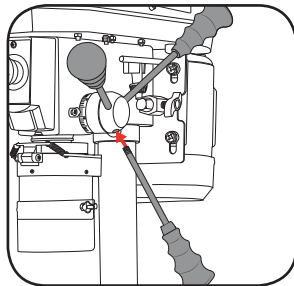

8. To fit the keyed chuck, first place a piece of timber on the table and position the keyed chuck with the jaws retracted under the drive shaft. Raise the table toward the drive shaft until the chuck is approximately 25mm from the drive shaft.

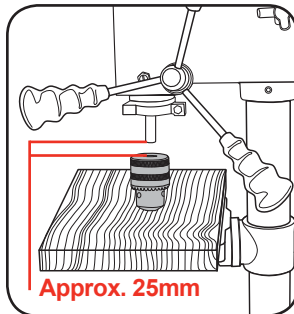

9. To secure the keyed chuck to the drive shaft gently lower the drive shaft using the feed wheel handles until the drive shaft is pushed into the rear of the keyed chuck. A gentle tap on the timber is required to secure the keyed chuck onto the tapered drive shaft.

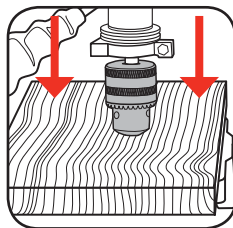

Installing and removing drill bits

1. Using the chuck key, loosen the jaws of the chuck by rotating in an anti-clockwise direction.

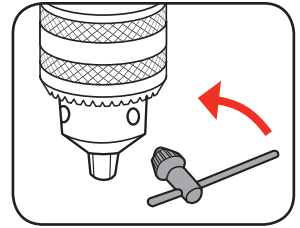

2. Insert the drill bit fully into the keyed chuck.

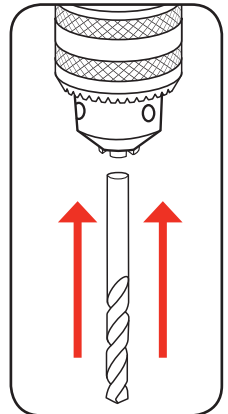

3. Whilst holding the drill bit in one hand, rotate the top collar of the keyed chuck in a clockwise direction. Ensure that you tighten all 3 holes in the keyed chuck using the chuck key to securely tighten the jaws and hold the drill bit in position.

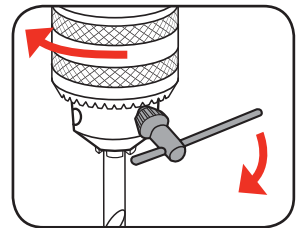

ADJUSTMENTS

2. HEIGHT & ANGLE ADJUSTMENTS

WARNING! BEFORE MAKING ANY ADJUSTMENTS, ENSURE THE DRILL PRESS IS DISCONNECTED FROM THE MAINS POWER.

Adjusting the table height

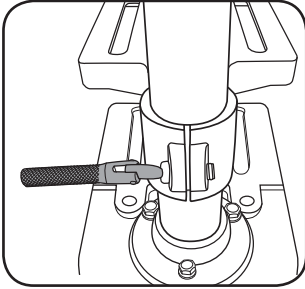

1. Loosen the table support lock.

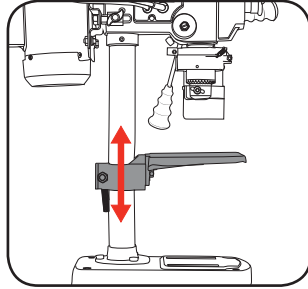

2. Set the desired table height and tighten the table support lock to secure the table in position.

Adjusting the table angle

The table can be adjusted up to 45° to the left or right.

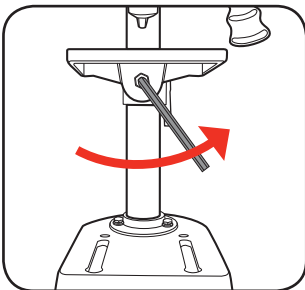

1. Loosen the table support angle bolt (located below the table) by rotating anti-clockwise using the hex key.

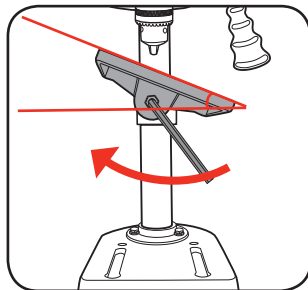

2. Align and set the desired angle. Tighten the table support angle bolt by rotating in a clockwise direction to secure the table in position.

CAUTION! WHEN THE TABLE IS ANGLED/TILTED, ENSURE THE WORKPIECE IS CLAMPED TO THE TABLE.

3. DEPTH ADJUSTMENTS

Pre-setting the drilling depth

1. Loosen the depth adjustment lock nut by turning in an anti-clockwise direction.



2. Rotate the depth adjustment ring until the desired drilling depth aligns with the point indicator. Tighten the depth adjustment lock nut to secure this position.



3. Ensure the drill bit is secured in the chuck and then proceed to operate the drill press. Once the drill lowers to the selected depth, the stop will engage to prevent drilling any lower.

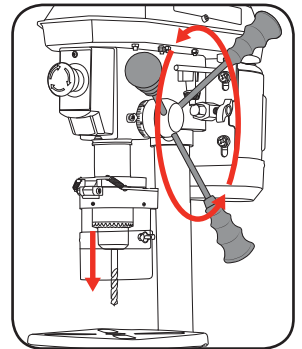

4. To disable the depth lock, loosen the depth adjustment lock nut and reset to the desired position. Having it in the highest position on the depth rod will provide maximum drilling capacity.

OPERATION

4. SPEED ADJUSTMENTS

Changing the speed

The speed of the drill press can be changed by adjusting the belts on the pulley system.

Using a smaller pulley on the spindle side increases the drill speed. Using a larger pulley on the motor side will also increase the drill speed.

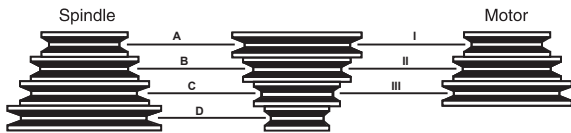

1	2	3	4	5	6	7	8	9
D - I	D - II	C - I	D - III	B - I	C - II	B - III	A - II	A - III
500/min	680/min	770/min	830/min	980/min	1100/min	1600/min	2000/min	2500/min

1. Loosen the 2 belt tension knobs.

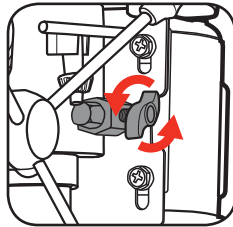

2. Push the motor towards the head assembly and tighten the belt tension knobs.

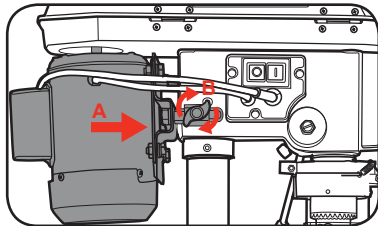

3. To adjust the belt speed, move the belts to the correct pulley step for the speed required. See the diagram above for all belt configurations.

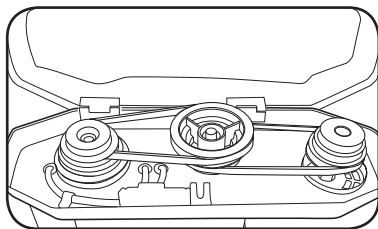

When moving the belt, it is easier to place the belt onto the small pulley first and then turn it onto the larger pulley.

4. To apply tension to the belt once it has been fitted to a new speed setting, loosen the belt tension knobs. Pull the motor away from the head assembly and then re-tighten the belt tension knob.

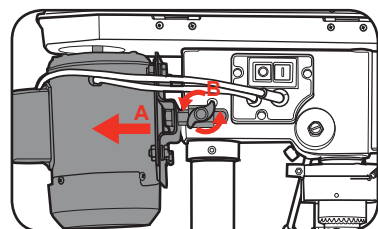

5. Ensure the pulley cover is closed and secured with the pulley cover screw.

5. CONTROLS

Turning On and Off

WARNING! THE POWER SUPPLY FOR THIS PRODUCT SHOULD BE PROTECTED BY A RESIDUAL CURRENT DEVICE (RATED AT 30MA OR LESS). A RESIDUAL CURRENT DEVICE REDUCES THE RISK OF ELECTRIC SHOCK.

Note: The pulley cover is fitted with a safety switch and must be closed to operate the drill press.

1. Switch the drill press on by pressing the green (I) button on the switch.
2. Switch the drill press off by pressing the red (O) button on the switch.
3. Secure your workpiece to the table if possible, use a vice or clamps (not supplied).

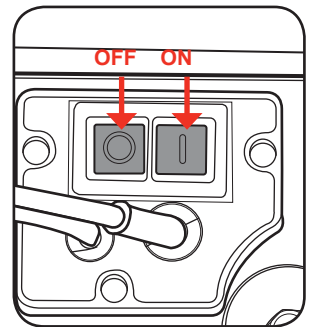

Emergency Stop Button

An emergency off button is located at the front of the drill press to stop the unit quickly. Simply press this button in, to switch the unit off. This button must then be reset before the drill can be started again.

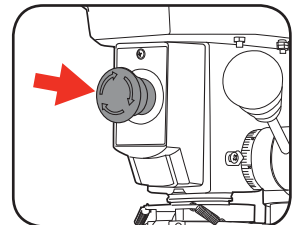

1. Turn the button clockwise until it pops out to reset it.

6. USING THE DRILL PRESS

Operating the drill press

1. Ensure the drill press is switched off and disconnected from the power supply.

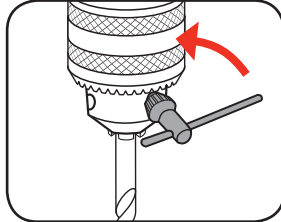

2. Loosen the jaws of the keyed chuck with the chuck key by turning in an anti-clockwise direction and insert the selected drill bit into the chuck as far as it will go.

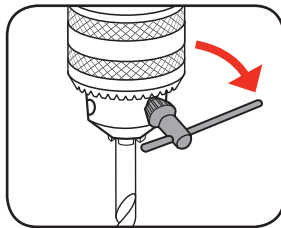

3. Ensure that the drill bit is centred in the chuck and tighten the chuck jaws with the chuck key in a clockwise direction. Tighten all three holes to ensure the drill bit is secured evenly by each jaw.

4. Select your drilling depth and secure the depth adjustment lock nut in position.

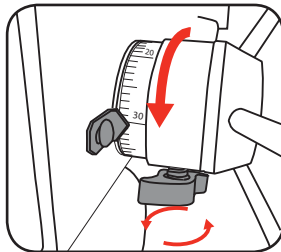

5. Adjust the table to your desired height and ensure the hole in the centre of the table is aligned with the drill bit. Switch the unit on by pressing the green (I) button.

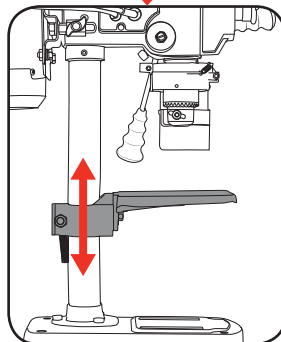

6. Slowly rotate the feed wheel handles to bring the drill bit down towards the table and into your workpiece. After drilling a hole, release the feed wheel handles slowly to return the chuck to its original position.

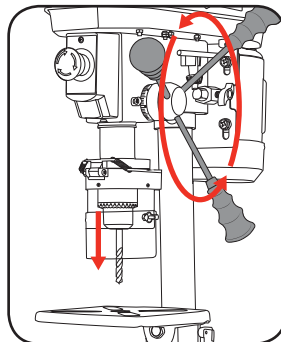

7. Continue the operation until the task is completed. When completed, switch the drill press off by pressing the red (O) button on the switch.

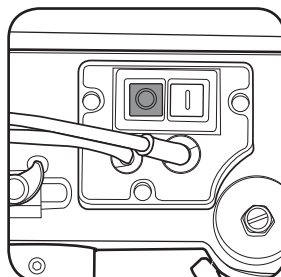

7. TROUBLESHOOTING

WARNING! FAILURE TO UNPLUG YOUR DRILL PRESS COULD RESULT IN ACCIDENTAL STARTING CAUSING POSSIBLE SERIOUS PERSONAL INJURY.

Problem	Cause	Remedy
Drill press will not start	Emergency off button is pressed	Rotate the emergency off button clockwise to disengage
	Pulley cover not secured	Check the pulley cover is closed and lowered correctly in position
	Power cord not connected to the mains power supply	Ensure that the power cord is connected to the mains power
	Power fault	Check the mains power supply
	Power cord damage	Use an authorised service centre to repair or replace
	Faulty switch or motor	Use an authorised service centre to repair or replace
Noisy operation	Incorrect belt tension	Adjust tension as required
Drill bit burns	Incorrect speed	Adjust speed as described in the "Changing the speed" section
Excessive drill bit wobble	Bent or damaged drill bit	Use a new drill bit
	Drill bit is not securely placed in the keyed chuck	Remove the drill bit and reinsert correctly, ensure the chuck jaws are fully tightened
	The keyed chuck is not installed correctly	Ensure you install the keyed chuck correctly
Drill bit binds in workpiece	Belt tension is set incorrectly	Re-adjust the belt tension

MAINTENANCE

7. GENERAL MAINTENANCE



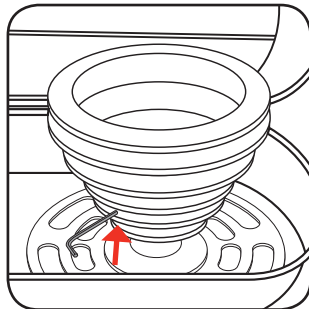

WARNING! ENSURE THE DRILL PRESS IS DISCONNECTED FROM THE POWER SUPPLY BEFORE PERFORMING ANY MAINTENANCE.

1. Ball bearings are packed with grease at the factory. No further lubrication of bearings is required.
2. Lubricate all moving parts periodically. Wipe the column, table and base with an oily cloth to minimise corrosion.
3. Keep air vents clean of dust and dirt.
4. Remove dust and dirt from the drill press regularly with a soft cloth, brush or compressed air.
5. If the power cord is damaged, have it replaced by an electrician or a power tool repairer.
6. Regularly check that all bolts, screws and nuts are securely fixed as these could work loose during normal operation.
7. If the drive belt will not align with the pulleys. The pulleys may be worn and need to be replaced. To remove the pulleys, use the 3mm hex key provided. Loosen in an anti-clockwise direction.

Note: Ozito Industries will not be responsible for any damage or injuries caused by the repair of the drill press by an unauthorised person or by mishandling of the drill press.



DESCRIPTION OF SYMBOLS

V	Volts	Hz	Hertz
~	Alternating Current	W	Watts
/min	Revolutions or reciprocations per minute	n₀	No load speed
Hp	Horse Power		Do not use outdoors or expose to rain
	Regulatory Compliance Mark (RCM)		Warning
	Read Instruction Manual		Wear eye, ear & breathing protection

CARING FOR THE ENVIRONMENT



Power tools that are no longer usable should not be disposed of with household waste but in an environmentally friendly way. Please recycle where facilities exist. Check with your local council authority for recycling advice.



Recycling packaging reduces the need for landfill and raw materials. Reuse of recycled material decreases pollution in the environment. Please recycle packaging where facilities exist. Check with your local council authority for recycling advice.

SPARE PARTS

Spare parts can be ordered from the Special Orders Desk at your local Bunnings Warehouse.

For further information, or any parts not listed here, visit www.ozito.com.au or contact Ozito Customer Service:

Australia 1800 069 486

New Zealand 0508 069 486

E-mail: enquiries@ozito.com.au

ELECTRICAL SAFETY

 **WARNING!** When using mains-powered tools, basic safety precautions, including the following, should always be followed to reduce risk of fire, electric shock, personal injury and material damage.

Read and understand the manual prior to operating this tool.

Save these instructions and other documents supplied with this tool for future reference.

The electric motor has been designed for 230V and 240V only. Always check that the power supply corresponds to the voltage on the rating plate.

Note: The supply of 230V and 240V on Ozito tools are interchangeable for Australia and New Zealand.

If the supply cord is damaged, it must be replaced by a qualified electrician or a power tool repairer in order to avoid a hazard.

If operating a power tool in a damp location is unavoidable use a residual current device (RCD) protected supply. Use of an RCD reduces the risk of electric shock.

Using an Extension Lead

Always use an approved extension lead suitable for the power input of this tool. Before use, inspect the extension lead for signs of damage, wear and ageing. Replace the extension lead if damaged or defective.

When using an extension lead on a reel, always unwind the lead completely. Use of an extension lead not suitable for the power input of the tool or which is damaged or defective may result in a risk of fire and electric shock.

GENERAL POWER TOOL SAFETY WARNINGS

 **WARNING!** Read all safety warnings and all instructions. Failure to follow the warnings and instructions may result in electric shock, fire and/or serious injury.

Save all warnings and instructions for future reference. The term "power tool" in the warnings refers to your mains-operated (corded) power tool or battery-operated (cordless) power tool.

1. Work area safety

- Keep work area clean and well lit.** Cluttered or dark areas invite accidents.
- Do not operate power tools in explosive atmospheres, such as in the presence of flammable liquids, gases or dust.** Power tools create sparks which may ignite the dust or fumes.
- Keep children and bystanders away while operating a power tool.** Distractions can cause you to lose control.

2. Electrical safety

- Power tool plugs must match the outlet. Never modify the plug in any way. Do not use any adapter plugs with earthed (grounded) power tools.** Unmodified plugs and matching outlets will reduce risk of electric shock.
- Avoid body contact with earthed or grounded surfaces, such as pipes, radiators, ranges and refrigerators.** There is an increased risk of electric shock if your body is earthed or grounded.
- Do not expose power tools to rain or wet conditions.** Water entering a power tool will increase the risk of electric shock.
- Do not abuse the cord. Never use the cord for carrying, pulling or unplugging the power tool. Keep cord away from heat, oil, sharp edges or moving parts.** Damaged or entangled cords increase the risk of electric shock.
- When operating a power tool outdoors, use an extension cord suitable for outdoor use.** Use of a cord suitable for outdoor use reduces the risk of electric shock.
- If operating a power tool in a damp location is unavoidable, use a residual current device (RCD) protected supply.** Use of an RCD reduces the risk of electric shock.

3. Personal safety

- Stay alert, watch what you are doing and use common sense when operating a power tool. Do not use a power tool while you are tired or under the influence of drugs, alcohol or medication.** A moment of inattention while operating power tools may result in serious personal injury.
- Use personal protective equipment. Always wear eye protection.** Protective equipment such as dust mask, non-skid safety shoes, hard hat, or hearing protection used for appropriate conditions will reduce personal injuries.
- Prevent unintentional starting. Ensure the switch is in the off-position before connecting to power source and/or battery pack, picking up or carrying the tool.** Carrying power tools with your finger on the switch or energising power tools that have the switch on invites accidents.

- Remove any adjusting key or wrench before turning the power tool on.** A wrench or a key left attached to a rotating part of the power tool may result in personal injury.
- Do not overreach. Keep proper footing and balance at all times.** This enables better control of the power tool in unexpected situations.
- Dress properly. Do not wear loose clothing or jewellery. Keep your hair, clothing and gloves away from moving parts.** Loose clothes, jewellery or long hair can be caught in moving parts.
- If devices are provided for the connection of dust extraction and collection facilities, ensure these are connected and properly used.** Use of dust collection can reduce dust-related hazards.
- Do not let familiarity gained from frequent use of tools allow you to become complacent and ignore tool safety principles.** A careless action can cause severe injury within a fraction of a second.

4. Power tool use and care

- Do not force the power tool. Use the correct power tool for your application.** The correct power tool will do the job better and safer at the rate for which it was designed.
- Do not use the power tool if the switch does not turn it on and off.** Any power tool that cannot be controlled with the switch is dangerous and must be repaired.
- Disconnect the plug from the power source and/or the battery pack from the power tool before making any adjustments, changing accessories, or storing power tools.** Such preventive safety measures reduce the risk of starting the power tool accidentally.
- Store idle power tools out of the reach of children and do not allow persons unfamiliar with the power tool or these instructions to operate the power tool.** Power tools are dangerous in the hands of untrained users.
- Maintain power tools. Check for misalignment or binding of moving parts, breakage of parts and any other condition that may affect the power tool's operation. If damaged, have the power tool repaired before use.** Many accidents are caused by poorly maintained power tools.
- Keep cutting tools sharp and clean.** Properly maintained cutting tools with sharp cutting edges are less likely to bind and are easier to control.
- Use the power tool, accessories and tool bits etc. in accordance with these instructions, taking into account the working conditions and the work to be performed.** Use of the power tool for operations different from those intended could result in a hazardous situation.
- Keep handles and grasping surfaces dry, clean and free from oil and grease.** Slippery handles and grasping surfaces do not allow for safe handling and control of the tool in unexpected situations.

5. Service

- Have your power tool serviced by a qualified repair person using only identical replacement parts.** This will ensure that the safety of the power tool is maintained.



DRILL PRESS SAFETY WARNINGS

 **WARNING!** For your own safety, do not try to use your drill press or plug it in until it is completely assembled and installed according to the instructions and until you have read and understood the following:

This appliance is not intended for use by young or infirm persons unless supervised by a responsible person to ensure that they can use the appliance safely. Young children should be supervised to ensure that they do not play with the appliance.

- Your drill press must be bolted securely to a workbench. In addition, if there is any tendency for your drill press to move during certain operations, bolt the workbench to the floor.
- This drill press is intended for use in dry conditions and indoor use only.
- Always wear safety goggles which comply to a recognised standard. Use a face or dust mask along with safety goggles if the drilling operation is dusty. Use ear protectors, especially during extended periods of operation.
- Do not try to drill material too small to be securely held. Do not drill material that does not have a flat surface unless it is clamped securely.
- Always keep hands out of the path of the drill bit. Avoid awkward hand positions where a sudden slip could cause your hand to move into the drill bit.
- Do not install or use any drill bit that exceeds 175mm (7 inches) in length or extends more than 150mm (6 inches) below the chuck jaws. They can suddenly bend outwards or break.
- Do not use wire wheels, router bits, shaper cutters, circle (fly) cutters or rotary planers on this drill press.
- When drilling a large piece of material make sure it is fully supported at the table height.
- Do not perform any operation freehand. Always hold the workpiece firmly against the table so it will not rock or twist. Use clamps or a vice for unstable workpieces.
- Make sure there are no nails or foreign objects in the part of the workpiece to be drilled.
- Whenever possible, position the workpiece to contact the left side of the column; if it is too short or the table is tilted, clamp solidly to the table.
- If the workpiece overhangs the table such that it will fall or tip if not held, clamp it to the table or provide auxiliary support.
- Set the drill press to a speed appropriate to the job.
- Do not start the drill press while the drill bit is touching the workpiece.
- When using a drill press vice, always fasten it to the table.

- Make sure all clamps and locks are firmly tightened before drilling.
- Securely lock the head and table support to the column, and the table to the table support before operating your drill press.
- Never turn your drill press on before clearing the table of all objects (tools, scraps of wood etc.)
- Before starting the operation, jog the motor switch to make sure the drill bit does not wobble or vibrate.
- Let the spindle reach full speed before starting to drill. If your drill press makes an unfamiliar noise or if it vibrated excessively, stop immediately, turn the drill press off and unplug it. Do not restart until the problem is corrected.
- Do not perform layout assembly or setup work on the table while the drill press is in operation.
- Do not exceed the rpm stated on the bit or accessory. See the instructions that come with the accessory.
- When drilling large diameter holes, clamp the workpiece firmly to the table. Otherwise, the bit may grab and spin the workpiece at high speed. Do not use fly cutters or multiple-part cutters, as they can come apart or become unbalanced in use.
- Make sure the spindle has come to a complete stop before touching the workpiece.
- To avoid injury from accidental starting, always turn the switch off and unplug the drill press before installing or removing any accessory attachment or making any adjustment.
- This appliance is not intended for use by persons (including children) with reduced physical, sensory or mental capabilities, or lack of experience and knowledge, unless they have been given supervision or instruction concerning use of the appliance by a person responsible for their safety.
- Children should be supervised to ensure that they do not play with the appliance.
- If the supply cord is damaged, it must be replaced by the manufacturer, its service agent or similarly qualified persons in order to avoid a hazard.

 **CAUTION:** Do not expose to rain or use in damp locations.
 **WARNING!** For your own safety read instruction manual before operating drill press. Wear eye protection, do not wear gloves, necktie or loose clothing, clamp workpiece or brace against column to prevent rotation, use recommended speed for drill accessory and workpiece material.