



External cladding

Technical specification

HardieTex™ system



James Hardie
A smarter way to build

AUSTRALIA MAY 2014

CONTENTS

1	INTRODUCTION	2
1.1	Applications	2
1.2	Outline of system	3
1.3	Factors to be considered	3
2	FRAMING AND FIXING	4
2.1	Framing	4
2.2	Fixing	5
2.3	Fasteners	5
3	SHEET INSTALLATION	6
3.1	General installation	6
3.2	Orientation	6
3.3	Set jointing	7
3.4	Movement joints	7
3.5	Corners	7
3.6	Sheet layout around openings	7
3.7	Curved walls	7
3.8	Moisture management	7
4	MOVEMENT JOINTS	8
4.1	General	8
4.2	Control joints	8
4.3	Structural joints	8
4.4	Construction joints	8
5	DECORATIVE TREATMENT	8
5.1	Coating	8
5.2	Decorative trims	8
6	SAFE WORKING PRACTICES	9
	Warning	9
	Recommended safe working practices	9
	Working instructions	9
	Hole-forming	10
	Storage and handling	10
	Quality	10
7	PRODUCT INFORMATION	10
7.1	General	10
7.2	Product mass	10
7.3	Durability	10
7.4	Alpine regions	10
8	COMPONENTS	11
9	DETAILS	12
9.1	General	12
9.2	Slab on ground and platform floors	12
9.3	Windows	12
9.4	Eaves lining	12
10	WARRANTY	24

MADE IN AUSTRALIA

1 INTRODUCTION

1.1 APPLICATIONS

Current design trends in residential construction favour the use of colour and texture for external walls. The HardieTex™ system has been developed to deliver this colour and texture, along with design flexibility and a robust finish, that will withstand many years of exposure to the elements.

The design flexibility of the HardieTex™ system is further enhanced by the use of architectural profiles that provide a wide range of options for architectural detailing.

The freedom of lightweight, versatile HardieTex™ system makes it easy to turn the most inspiring design into reality, without heavy and often costly engineering detail.

The HardieTex™ system is adaptable, and offers new design and construction possibilities, even with a limited budget. With the HardieTex™ system, you can have design freedom, without compromising quality and cost-effectiveness.

Start with the strong, stable, lightweight and durable HardieTex™ system. Then sculpt the basic form of your design, whether it is strikingly modern, or monumentally grand.

The lightweight properties of the HardieTex™ system makes it the ideal material for additions. Perfect for second-storey additions, the HardieTex™ system allows you to build with a reduced load, compared to building with masonry. This saves time and money.

HardieTex™ base sheets are designed to be coated with beautiful colours and textures, so it is easy to select a finish that will seamlessly match new areas to an existing building, or complement any materials used in the original structure.

HardieTex™ base sheets are easily fixed to timber and steel wall frames using common fasteners.

The specifier or the party responsible for the project must ensure the details in this specification are appropriate for the intended application and that additional detailing is performed for specific design or any areas that fall outside the scope and specifications of this manual.

Make sure your information is up to date

When specifying or installing James Hardie products, ensure you have the current manual. If you're not sure you do, or if you need more information, visit www.jameshardie.com.au or Ask James Hardie™ on 13 11 03.



1.2 OUTLINE OF SYSTEM

1.2.1 Component 1- HardieTex™ base sheets

Component 1 is the specifically designed 7.5mm thick HardieTex™ base sheet. These sheets are recessed along their two longer sides to facilitate the construction of concealed joints. The sheets are fixed to timber or steel framing and provide a strong impact-resistant substrate for Component 2, the texture system.

These sheets are supplied pre-primed, ready for the application of the texture system.

HardieTex™ base sheets can also be used as structural bracing. Refer to the James Hardie bracing manual for information on bracing fixing recommendations.

NOTE

HardieTex™ system are clearly identified by their blue colour and are marked with "HARDIETEX NAIL AT 200mm, SUPPORT ALL JOINTS".

1.2.2 Component 2 - texture system

HardieTex™ base sheets must be finished with a specialised texture coat system that incorporates jointing reinforcement and a texture coat.

The coating finish, available in a variety of textures, colours and gloss levels, is site applied. The joint and texture coat used must be from the same manufacturer and must form a complete system that is recommended by that manufacturer over HardieTex™ base sheets. This will ensure compatibility and availability of system warranties by the texture coat manufacturers.

The texture system must be applied by an applicator approved and trained by the texture coat manufacturer. The manufacturer will be responsible for providing the customer with the warranty for the coating and sheet joints. James Hardie will warrant only the HardieTex™ base sheet component of the system.

Optional architectural mouldings can be used to provide detailing flexibility.

For information on texture coat manufacturers Ask James Hardie™ on 13 11 03.

1.3 FACTORS TO BE CONSIDERED

The HardieTex™ system is designed to provide a monolithic finish. The success of the system relies on a number of factors outside the control of James Hardie. We recommend that you work closely with texture coat manufacturers and trained applicators, even before installing the HardieTex™ base sheets to select the right finish and texture coat system for you.

Seeking the advice of the texture coat manufacturer will ensure you select the most appropriate product compatible with HardieTex™ base sheets. By involving applicators early they can advise of particular texture coat requirements and this can sometimes save you money.

To get the best possible finish we recommend the following:

A straight frame

The final finish is dependent on the straightness of the frame. The frame can be checked and straightened if it is out of tolerance, refer to Section 2 in this manual for the suggested frame straightness tolerances.

Avoiding large unbroken wall areas

Trim, window and door openings break the starkness of a wall elevation, whereas in large unbroken wall elevations, joints can sometimes be visible. The sheet layout around openings is important, refer to Section 3 in this manual for recommended sheet layout.

A minimum 2mm thick texture coat

A high build texture coat will help conceal joints. Heavier texture, such as scratch coats, will also help provide a monolithic finish. For specialist advice contact the texture coat manufacturer.

A low gloss finish

A low gloss finish will help diffuse glancing light. For specialist advice contact the texture coat manufacturer.

Use of light coloured paints

Avoid dark coloured coatings on walls subject to long periods of sun exposure. For specialist advice contact the texture coat manufacturer and refer to section 5 in this manual.

Glancing light

For any number of reasons outside the control of James Hardie, including frame movement, sheet alignment as well as the jointing products and methods used, the actual joint may be slightly (several microns) raised or lowered compared to the adjoining sheets. Such joints may be clearly evident under glancing light, casting visible shadows of the minute and uneven projections of the joints.

We recommend that you install eaves on your house. The eaves will reduce glancing light, highlighting joints. Glancing light is light that is nearly parallel to the surface of the wall and casts visible shadows and uneven projections of the joints. Just like rendered masonry any uneven projections will be highlighted. Including eaves on your house can also dramatically reduce the impact that the sun, wind and rain will have on your home.

It is important to consider all these points to achieve the best results from the HardieTex™ system.

2 FRAMING AND FIXING

2.1 FRAMING

2.1.1 General

HardieTex™ base sheets can be fixed to either timber or light gauge steel domestic framing. The framing must comply with relevant building regulations and standards and the requirements of this manual.

All HardieTex™ base sheet edges must be supported. Adequate framing must be provided to ensure all sheet edges can be supported.

All studs and noggings must be checked with a long straight edge for line and face accuracy, to ensure the stud wall has a true and accurate outside face. A suggested maximum tolerance of 3-4mm in 3000mm of the length and height of frame will give best results. See Table 1.

NOTE

HardieTex™ base sheets will not straighten excessively warped frames and such warping may still be visible after the texture coating is applied.

TABLE 1

SUGGESTED FRAME STRAIGHTNESS TOLERANCES	
STRAIGHT EDGE (mm)	TOLERANCES (mm)
600	1 - 2
1200	2 - 3
3000	3 - 4

2.1.2 Timber

'Timber used for house construction must have the level of durability appropriate for the relevant climate and expected service life and conditions including exposure to insect attacks or moisture, which could cause decay.'

Reference AS 1684.2 'Residential Timber Framed Construction'.

Only seasoned timber must be used. When the inter-floor wall height exceeds the sheet length, and horizontal sheet joints need to be introduced, use only kiln dried timber.

NOTE

Unseasoned timber must not be used as it is prone to shrinkage and can cause sheets and frame to move, causing undue stresses on sheet joints.

The timber framing thickness at sheet joints must be a minimum of 42mm. See Figure 1.

35mm wide timber must not be used at any sheet joint because of insufficient sheet landing width. Where timber less than 42mm wide is used, provide double studs at sheet joints. See Figure 2.

TABLE 2

MAXIMUM STUD AND FASTENER SPACING FOR WIND CATEGORIES (mm)								
To AS 4055 - 1992	non-cyclonic	N1	N2	N3		N4	N5	N6
	cyclonic				C1	C2	C3	C4
7.5mm HARDIETEX™ BASE SHEETS								
Stud spacing	within 1200mm of the external corners of the building	600	600	600	450	450	300	300
	elsewhere	600	600	600	450	450	450	450
Fastener spacing	within 1200mm of the external corners of the building	200	200	200	200	150	150	125
	elsewhere	200	200	200	200	200	200	150

Where frames are to be supplied by frame and truss manufacturers, advise the manufacturer that the frames are to be designed for HardieTex™ system. James Hardie has prepared a frame and truss checklist to help frame and truss manufacturers understand the framing needs of HardieTex™ system. Contact Ask James Hardie™ on 13 11 03 for more information.

2.1.3 Steel

Use of steel framing must be in accordance with NASH standard for Residential and Low-Rise Steel Framing Part 1: Design Criteria and the framing manufacturer's specifications. Framing members must have a base metal thickness (BMT) between 0.55mm to 1.6mm. The steel framing must have the appropriate level of durability required to prevent corrosion.

Minimum flange width at sheet joints must be 38mm. This will provide adequate support for fixing two HardieTex™ sheet edges. Where narrower sections are used, double studs must be provided at sheet joints. See figure 3.

Sheets must not be fixed directly to drawn steel or hot-rolled steel sections. These members must be battened out with 42mm minimum wide finished timber battens or light gauge 38mm wide metal furring channels.

2.1.3.1 Thermal Break

The Building Code of Australia sections J1.5 and 3.12.1 volumes 1 and 2 respectively, state for both residential and commercial buildings a thermal break with an R 0.2m² K/W must be installed behind external cladding where the cladding and internal lining make direct contact with the same metal frame. For more information on the HardieBreak™ thermal strip, please refer to the installation manual at www.jameshardie.com.au

2.1.4 Frame layout

Framing must be laid out to accommodate sheet joints at 900mm or 1200mm centres.

Framing to suit HardieTex™ base sheets, must comply with the following maximums:

- Stud spacing 600mm for 1200mm wide sheets.
- Stud spacing 450mm for 900mm wide sheets.
- Noggings may be staggered, installed flush with the outside face of studs.

NOTE

Double studs are required at vertical movement joints. Refer to Section 4 for locations and details of movement joints.

Where HardieTex™ base sheets are to be installed in higher wind areas, stud spacings must be reduced. Refer to Table 2 for spacings.

Where framing does not coincide with sheet joints, additional framing must be installed. See Figure 4 for additional framing details.

2.1.5 Stud setout

It will save time and money if the first stud is set out from the corner of the frame and not from the first stud centre. This will eliminate the need for extra framing as all sheet edges can coincide with framing. See Figure 5.

2.1.6 Framing for curved walls

For maximum stud spacing and allowable radii for curved walls see Table 3.

Greater wall heights may be obtained provided that a trim is used to cover sheet joints.

TABLE 3

CURVED WALLS					
	Min. bending radii concave walls (mm)	Min. bending radii convex walls (mm)	Max. height of wall (mm)	Max. stud spacing (mm)	Max. fixing spacing (mm)
Horizontal sheet fixing	2400	1800	1200	400	200
Vertical sheet fixing	6000	4000	3000	400	200

2.2 FIXING

2.2.1 General

All sheet edges must be supported by framing.

Sheets must be butted hard together, except where movement joints are required.

Where sheets are not used as sheet bracing, locate fasteners at centres given in Table 2 around the perimeter and on the intermediate stud. Fasteners must not be less than 12mm from sheet edges and 50mm from corners, as shown in Figure 6.

It is recommended to fix from the centre of the sheet and work outwards, to ensure sheets are hard against the frame, to avoid drumminess.

2.2.2 Bracing

HardieTex™ base sheets can also be used as structural bracing. Refer to the James Hardie structural bracing design manual or for further information Ask James Hardie™ on 13 11 03.

NOTE

No structural bracing is achieved if a thermal break is used between the frame and cladding.

2.2.3 High wind and cyclonic areas

In high wind and cyclonic areas, the stud and fastener spacings must be reduced in accordance with Table 2.

2.3 FASTENERS

2.3.1 General

Select the fastener suitable for the required framing from the Components. See Section 8.

NOTE

At least Class 3 external grade fasteners must be used for all external applications.

2.3.2 Fastener durability

Fasteners must have the appropriate level of durability required for the intended project. This is of particular importance in coastal areas, areas subject to salt spray and other corrosive environments.

Fasteners must be fully compatible with all other materials that they are in contact with to ensure the durability and integrity of the assembly.

Contact fastener manufacturers for more information.

2.3.3 Fasteners to timber

Hand nailing - use 2.8 x 30mm fibre cement nails for fixing HardieTex™ base sheets to timber framing.

Adhesives must not be used to attach sheets to the frame.

NOTE

Fasteners must not be overdriven as this can reduce the holding capacity of the sheet. If nailing depth cannot be controlled adequately when gun nailing, under-drive fasteners then tap flush with a hammer. See Figure 7.

When gun nailing, refer to Table 4.

TABLE 4

GUN NAILING NOTES				
COIL NAILER		NAILS		
Manufacturer	Name	Manufacturer	Name	Size
Hitachi	VH650 coil nailer	Otter	Galv. coil nail	38mm x 2.5mm dia. 45mm x 2.2mm dia. 50mm x 2.2mm dia.
Paslode	Impulse compact nailer (B20544)	Paslode	Impulse DekFast® 50mm Value Pack (B20561V)	50mm x 2.87mm dia.
			Impulse DekFast® 50mm Handy Pack (B20557)	50mm x 2.87mm dia.
Duo-Fast	KD665A coil nailer (Part No. D40040)	Duo-Fast	C27/32 GD coil nail (D41800)	32mm x 2.7mm dia.
Stanley-Bostitch	N80C coil nailer	Stanley-Bostitch	AC45P250 gal coil nail	45mm x 2.5mm dia.
Senco	SCN-60 coil nailer (fitted with adjustable depth of drive)	Senco	BTN 45 ADB Weatherex gal and Sencoted	45mm x 2.5mm dia.

NOTES

1. Fasteners with equivalent dimensions, (ie head size and shape, shank diameter and length to those above) are acceptable for use.
2. All fasteners are to be galvanised or suitably coated for intended external application.
3. Nailing guns must be fitted with flush drive attachments.
4. Some nailing guns incorporate an adjustable head set to control nail depth (eg Duo-Fast coil nailer and Senco coil nailer.)
5. When gun nailing, apply pressure to the face of the cladding by holding the cladding against the stud to reduce blow out at back of the sheet.

Nail gun manufacturers have supplied the information contained in this table. Should a nail gun model or nail shown in the table not be available, please contact the relevant nail gun manufacturer for advice. If the nail gun overdrives sheets, contact nail gun manufacturer for advice.

2.3.4 Fastening to steel

For steel framing of thickness 0.55mm to 0.75mm BMT, 40mm Buildex FibreTEKS self drilling screws.

For steel framing of thickness 0.80mm to 1.6mm BMT, use 8g-40mm HardieDrive® screws.

Fasteners should be screwed as close as possible to the stud corners to avoid deflection of the stud flange. See Figure 8.

2.3.5 Screw gun specification

Use variable speed screw guns with high torque, a maximum speed of 2500rpm, fitted with a depth control attachment.

Set the depth control attachment to avoid overdriving. As the screw thread begins to pull into the steel frame, drop the revs back to bed the head flush with the surface of the sheet.

3 SHEET INSTALLATION

3.1 GENERAL INSTALLATION

Planning sheet layout is an essential part of installation to minimise the number of sheet joints and material wastage. The two main areas to be considered are sheet orientation and jointing.

In all cases use full sheets and do not use offcuts to clad walls. See Figure 9.

Sheets must be fixed vertically, commencing from a corner. Where steel framing is used, ensure studs are placed so sheets can be progressively fixed in the sequence indicated in Figure 6.

Where wall heights between floors are greater than a standard sheet, place small sheets at the top of the full sheet. See Figure 10.

Ensure that HardieTex™ base sheets are not finished hard against render, tiling, timber decks or concrete slab. Provision must be made for frame and sheet movement.

The bottom edge of HardieTex™ base sheets must not come into frequent contact with moisture. Ensure bottom edge of sheets are not buried or in an application where they will be exposed to ponding water.

3.2 ORIENTATION

3.2.1 Vertical

Vertical sheet installation layout is recommended for the following reasons:

- The longer sides of the sheets are recessed, facilitating vertical sheet joints, horizontally laid sheet sheets could require significant site grinding.
- Noggings can be staggered rather than in line.
- Vertical sheet installation minimises wastage as sheet lengths and widths suit wall heights and stud spacing.
- After coating, vertical joints are generally less obvious in glancing light conditions than horizontal joints.

3.2.2 Horizontal

Horizontal sheet layout is only recommended where the maximum depth of cladding is 1200mm (one sheet width), horizontal sheet installation is more suitable for applications such as fascias.

When fixing sheets horizontally. Refer to Table 2 for fastener spacings. Ensure sheets are fastened to all studs.

3.3 SET JOINTING

The set (recessed-edge) joint is formed between adjoining vertical edges of HardieTex™ system refer to Figure 11.

The sheets are butted hard together with no gaps being left between sheets.

Set joints are also required at sheet ends where inter-floor heights are greater than the length of a standard sheet. See Figure 10.

HardieTex™ base sheets comes with two recessed edges to facilitate easy setting of the joints. If an additional recess is required, the recess can be site ground. See Figure 12.

Where edges have been site recessed, ensure correct primer has been used to pre-prime sheet recess before application of texture coat. Check with texture coat manufacturer for details on primers that are recommended for the texture coat system selected.

Use a portable angle grinder fitted with a strong thick diamond or carborundum blade or similar and a dust extraction unit. A suitable tool is an angle grinder fitted with the Hitachi Easy Bevel attachment and dust extraction apparatus.

3.4 MOVEMENT JOINTS

Movement joints are joints that control the structural movement between the sheets and frame. Generally these joints are required at wall runs over 5.4m and at floor levels. Refer to Section 4 for an explanation and details of movement joints.

3.5 CORNERS

External corners have either a system of continuous jointing and coating around the corner or are reinforced with a perforated corner angle. Refer to Table 5 for further external corner fixing requirements. Note at corners, both sheets should be either recessed or not recessed. See Figure 13.

An internal corner requires a 6mm gap between sheets that is filled with James Hardie joint sealant. See Figure 14.

TABLE 5

SUGGESTED FRAME STRAIGHTNESS TOLERANCES

Option	Requirements
PVC corner angle	Fix with fibre cement nails or screws at 200mm centres staggered alternate sides
Taped external corners	Tape and set corners to coating manufacturer's specifications

3.6 SHEET LAYOUT AROUND OPENINGS

At door and window openings, fix sheets around the openings so sheet edges do not coincide with the side of the door or window. This will reduce the possibility of joints cracking due to structural movement. See Figure 15 Option 1.

An alternative method to sheet around openings, is to provide a control joint at the line of an opening edge. Refer to Figure 15, Option 2 and Section 4 for movement joint details.

3.7 CURVED WALLS

Fix the centre of sheets to framing first and work outwards. Ensure sheets are hard against framing before fixing the perimeter of sheet. This will avoid drumminess. For stud and fastener spacing refer to Table 3, for curved wall details see Figure 16.

3.8 MOISTURE MANAGEMENT

3.8.1 General

It is the responsibility of the builders and designers to identify moisture related risks associated with any particular building design.

It is the responsibility of the builder to ensure appropriate moisture management is provided during framed wall construction through effective use of flashings, sealants and vapour permeable membranes such as vapour permeable sarking, building wraps, vapour retarders and damp proof course. Before installing sheeting, all wall openings, penetrations, intersections, connections, window sills, heads and jambs must incorporate appropriate flashing and waterproofing. Materials, components and their installation that are used to manage moisture in framed wall construction must, at a minimum, comply with the requirements of relevant standards, building codes and the manufacturer's specifications.

3.8.2 HardieWrap™ weather barrier

HardieWrap™ weather barrier must be installed under HardieTex™ cladding in accordance with the AS/NZS 4200.2 'Pliable building membranes and underlays – Installation' and HardieWrap™ Technical Data Sheet.

HardieWrap™ weather barrier delivers a triplesheild of protection to help against external weather penetration, internal condensation build-up and external heat penetration. Additionally, it enhances the wall thermal performance, please refer to www.jameshardie.com.au or www.accel.com.au for more information.

If using an alternate product in lieu of HardieWrap™ weather barrier, the designer must ensure that the product is fit for purpose and it has the following properties in accordance with AS/NZS 4200.1:

- Vapour barrier - low or medium
- Water barrier - high

In hot humid areas of Australia, HardieWrap™ weather barrier may not be suitable, refer to the building designer for a suitable membrane and Ask James Hardie® on 13 11 03.

Soft compressible insulation installed between the front of the wall studs and directly behind the external cladding can cause installation issues and is thus not recommended.

4 MOVEMENT JOINTS

4.1 GENERAL

Movement joints are designed to take up the structural movement between the sheets and building frame.

4.2 CONTROL JOINTS

4.2.1 Vertical control joints

Vertical control joints must be located in wall runs over 5.4m. For an example of vertical joint layout refer to Figure 17.

In this example the wall run is over 13.2m and requires at least 2 control joints located at a maximum wall run of 5.4m.

The control joints have been positioned to suit window and door openings. There are a number of alternative solutions to the location of vertical control joints. Location of control joints should be considered before installation of sheeting begins.

NOTE

Avoid placing control joints at doors or windows when using architraves.

These control joints require a 6mm gap between sheets. Refer to Figure 18 for details of vertical movement joints.

NOTE

Control joints must be formed using sheets with square cut edges and require a 6mm gap between sheets.

The vertical control joint must be supported on double studs. See Figure 18.

4.2.2 Horizontal control joints

Horizontal control joints must be located in walls at 3.6m maximum centres. They are also required at floor joist level and at gable ends. See Figure 17.

For details of horizontal control joints refer to Figure 19. When using architectural trims to cover control joints, ensure that trims are free to float over the bottom sheet by only fixing trim to upper sheet. This will allow for sheet and frame movement.

A horizontal control joint is also required for floor joists that are made from laminated timber "I" beams. These beams should be sufficiently packed out to accommodate fixing of HardieTex™ base sheets.

4.3 STRUCTURAL JOINTS

Structural movement joints must be provided when required by the designer. They must have total framing separation, including top and bottom plate, lining and cladding to allow for the structural framing expansion and contraction that can occur. See Figure 20.

4.4 CONSTRUCTION JOINTS

4.4.1 Vertical

Vertical construction joints are required where HardieTex™ base sheets construction intersects with an existing structure (See Figure 21 and Figure 22).

If cement render is applied to masonry wall, do not render hard up against HardieTex™ base sheet edge. Leave a 6mm joint between the render and HardieTex™ base sheet and fill with James Hardie joint sealant over bond breaker tape. Coating system must not cover sealant.

4.4.2 Horizontal

Horizontal construction joints are required where upper level HardieTex™ system construction joins an existing ground floor structure. See Figure 23.

5 DECORATIVE TREATMENT

5.1 COATING

Coating systems applied to the HardieTex™ base sheets must be sufficiently flexible to accommodate stresses across sheet joints. The jointing and coating systems suitable for use with HardieTex™ system are usually 100% acrylic or pure elastomeric high build texture coatings.

Use texture coating systems that have a minimum thickness of 2mm.

Refer to the coating manufacturer to determine suitable coating for use with HardieTex™ base sheets.

These systems must be applied by an applicator trained and approved by the coating manufacturer.

Refer to Section 1.3 at the beginning of this manual for further information on factors to be considered.

Where HardieTex™ base sheets are to be left uncoated for a considerable time, contact the texture coat manufacturer for advice on suitability of texture coat.

It is the responsibility of the applicator to use the appropriate components and compounds sufficient to eliminate cracking under normal building settlement conditions.

For more information regarding coating performance, maintenance and levels of finish refer to Fact Sheet T12 available from and produced by the Australian Paint Manufacturers' Federation Inc. This document is not to be used as a substitute for the manufacturer's requirements.

HardieTex™ base sheets must be texture coated within 90 days of the installation.

NOTE: In areas exposed to marine salt spray, it is recommended that texture coatings be applied as soon as possible after sheet fixing to prevent salt build up that could lead to fastener corrosion. For information on texture coats in marine environments contact the texture coat manufacturer.

The texture coat colour applied to both the HardieTex™ base sheets and PVC accessories, must have a Light Reflective Value (LRV) greater than 40%. Refer to the texture coat manufacturer for the coating's LRV.

James Hardie does not recommend tiling in an external application.

5.2 DECORATIVE TRIMS

Decorative mouldings, refer to Figure 32, can be used to enhance a building, or to create a distinctive style of building facade, eg Tuscan etc. In addition, they can also be strategically placed to hide movement joints.

Mouldings are available for various parts of a building, such as quoining, banding, or to trim windows or doors.

The following types of decorative mouldings are available:

- Cement based profiles (these have superior long-term durability and impact resistance).
- Expanded polystyrene with protective coating (eg fibreglass, polyurethane).

Where moulds are used to hide movement joints they must be allowed to float over the joint. The mould must be attached to one sheet only and must not bridge the joint. See Figure 19.

The moulds must be installed strictly in accordance with the manufacturer's specifications. For further information on moulding suppliers contact Ask James Hardie™ on 13 11 03.

NOTE: Decorative mouldings do not provide effective flashings. Openings and other critical areas must still be flashed using traditional construction methods.

6 SAFE WORKING PRACTICES

WARNING - DO NOT BREATHE DUST AND CUT ONLY IN WELL VENTILATED AREA

James Hardie products contain sand, a source of respirable crystalline silica which is considered by some international authorities to be a cause of cancer from some occupational sources. Breathing excessive amounts of respirable silica dust can also cause a disabling and potentially fatal lung disease called silicosis, and has been linked with other diseases. Some studies suggest smoking may increase these risks. During installation or handling: (1) work in outdoor areas with ample ventilation; (2) minimise dust when cutting by using either 'score and snap' knife, fibre cement shears or, where not feasible, use a HardieBlade™ Saw Blade and dust-reducing circular saw attached to a HEPA vacuum; (3) warn others in the immediate area to avoid breathing dust; (4) wear a properly-fitted, approved dust mask or respirator (e.g. P1 or P2) in accordance with applicable government regulations and manufacturer instructions to further limit respirable silica exposures. During clean-up, use HEPA vacuums or wet cleanup methods - never dry sweep. For further information, refer to our installation instructions and Material Safety Data Sheets available at www.jameshardie.com.au. FAILURE TO ADHERE TO OUR WARNINGS, MATERIAL SAFETY DATA SHEETS, AND INSTALLATION INSTRUCTIONS MAY LEAD TO SERIOUS PERSONAL INJURY OR DEATH.

JAMES HARDIE RECOMMENDED SAFE WORKING PRACTICES

CUTTING OUTDOORS

1. Position cutting station so wind will blow dust away from the user or others in working area.
2. Use one of the following methods based on the required cutting rate:

Best

- Score and snap
- Hand guillotine
- Fibreshear

Good

- Dust reducing circular saw equipped with HardieBlade™ Saw Blade and HEPA vacuum extraction.

CUTTING INDOORS

- Cut only using score and snap, hand guillotine or fibreshears (manual, electric or pneumatic).
- Position cutting station in a well-ventilated area.

REBATING/DRILLING/OTHER MACHINING

When rebating, drilling or machining you should always wear a P1 or P2 dust mask and warn others in the immediate area.

IMPORTANT NOTES

1. For maximum protection (lowest respirable dust production), James Hardie recommends always using "Best" - level cutting methods where feasible.
2. NEVER use a power saw indoors.
3. NEVER use a circular saw blade that does not carry the HardieBlade® logo.
4. NEVER dry sweep - Use wet suppression or HEPA vacuum.
5. NEVER use grinders.
6. ALWAYS follow tool manufacturers' safety recommendations.

P1 or P2 respirators should be used in conjunction with above cutting practices to further reduce dust exposures. Additional exposure information is available at www.jameshardie.com.au to help you determine the most appropriate cutting method for your job requirements. If concern still exists about exposure levels or you do not comply with the above practices, you should always consult a qualified industrial hygienist or contact James Hardie for further information.

WORKING INSTRUCTIONS

Refer to recommended safe working practices before starting any cutting or machining of product.

Score and snap

Score and snap is a fast and efficient method of cutting James Hardie building products using James Hardie's special tungsten tipped score and snap knife.

Preferably score on the face side of the product. Score against a straight edge and repeat the action to obtain adequate depth for clean break – normally one third of sheet thickness. Snap upwards to achieve break. Smooth any rough edges with a rasp.

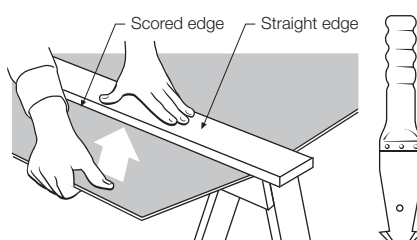

Hand guillotine

Make guillotine cut on the off-cut side of line to allow for the thickness of

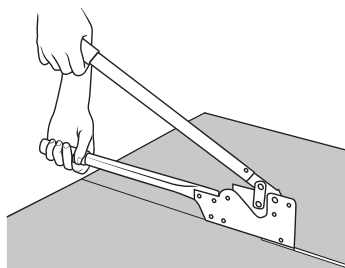

the blade.

Fibreshear

An electrically powered, fast, clean and effortless way of cutting James Hardie building products, especially around curves such as archways. Make fibreshear cut on the 'off-cut' side of the line to allow for the

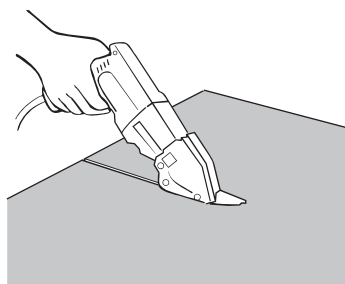

thickness of the shear.

7 PRODUCT INFORMATION

HardieBlade™ Saw Blade

The HardieBlade™ Saw Blade used with a dust-reducing saw and HEPA vacuum extraction allows for fast, clean cutting of James Hardie fibre cement products. A dust-reducing saw uses a dust deflector or a dust collector which can be connected to a vacuum system. When sawing, clamp a straight-edge to the sheet as a guide and run the saw base plate along the straight edge when making the cut.

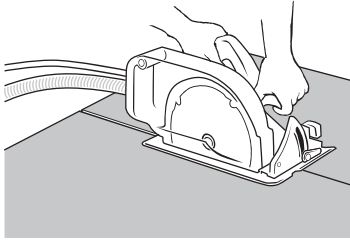

HOLE-FORMING

For smooth clean cut circular holes:

- Mark the centre of the hole on the sheet.
- Pre-drill a pilot hole.
- Using the pilot hole as a guide, cut the hole to the appropriate diameter with a hole saw fitted to a heavy duty electric drill.

For irregular holes:

- Small rectangular or circular holes can be cut by drilling a series of small holes around the perimeter of the hole then tapping out the waste piece from the sheet face.
- Tap carefully to avoid damage to sheets, ensuring the sheet edges are properly supported.

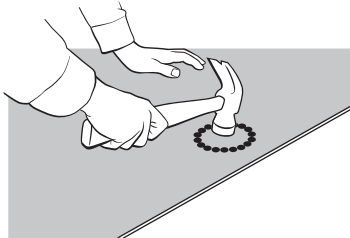

STORAGE AND HANDLING

To avoid damage, all James Hardie building products should be stored with edges and corners of the sheets protected from chipping.

James Hardie building products must be installed in a dry state and be protected from rain during transport and storage. The product must be laid flat under cover on a smooth level surface clear of the ground to avoid exposure to water, moisture, etc.

QUALITY

James Hardie conducts stringent quality checks to ensure any product manufactured falls within our quality spectrum. It is the responsibility of the builder to ensure the product meets aesthetic requirements before installation. James Hardie will not be responsible for rectifying obvious aesthetic surface variations following installation.

7.1 GENERAL

HardieTex™ base sheet is a cellulose fibre reinforced cement building product. The basic composition is Portland cement, ground sand, cellulose fibre and water.

HardieTex™ base sheet is manufactured to AS/NZS 2908.2 'Cellulose-Cement Products Part 2: Flat Sheets' (ISO 8336 'Fibre Cement Flat Sheets').

HardieTex™ system is classified Type A, Category 2 in accordance with AS/NZS 2908.2 'Cellulose-Cement Products'.

For Material Safety Data Sheets (MSDS) visit www.jameshardie.com.au or Ask James Hardie™ on 13 11 03.

7.2 PRODUCT MASS

Based on equilibrium moisture content the approximate mass of HardieTex™ base sheet is 10.10kg/m².

7.3 DURABILITY

7.3.1 Resistance to moisture/rotting

HardieTex™ base sheet has demonstrated resistance to permanent moisture induced deterioration (rotting) by passing the following tests in accordance with AS/NZS 2908.2:

- Water permeability (Clause 8.2.2)
- Warm water (Clause 8.2.4)
- Heat rain (Clause 6.5)
- Soak dry (Clause 8.2.5)

7.3.2 Resistance to fire

The HardieTex™ base sheet is suitable where non-combustible materials are required in accordance with C1.12 of the Building Code of Australia.

James Hardie building products have been tested by CSIRO in accordance with AS/NZS 3837 and are classified as conforming to Group 1 material (highest and best result possible), with an average specific extinction area far lower than the permissible 250m²/kg, as referenced in Specification C1.10a of the BCA."

7.3.3 Resistance to termite attack

Based on testing completed by CSIRO Division of Forest Products and Ensis Australia James Hardie building products have demonstrated resistance to termite attack.

7.4 ALPINE REGIONS

In regions subject to freeze/thaw conditions, all James Hardie fibre cement external cladding must be installed and painted in the warmer months of the year where the temperature does not create freeze and thaw conditions or paint issues. The cladding must be painted immediately after installation. In addition, fibre cement cladding must not be in direct contact with snow and/or ice build up for extended periods, e.g. external walls in alpine regions subject to snow drifts over winter.

Furthermore, a reputable paint manufacturer must be consulted in regards to a suitable product, specifications and warranty. The paint application must not be carried out if the air temperature or the substrate temperature is outside the paint manufacturer's recommendation including the specified drying temperature range.

James Hardie external cladding products are tested for resistance to frost in accordance with AS/NZS 2908.2 Clause 8.2.3.

8 COMPONENTS





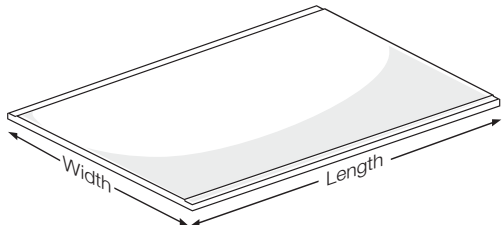

The following checklist describes the components required to install HardieTex™ system.

HARDIETEX™ BASE SHEET - SHEET PRIMED BLUE

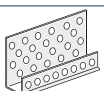
	Surface:	Flat sheet-blue coloured. Edges to long sides of sheets recessed for set jointing. Short sides square edged, to be site recessed where jointing is required. All HardieTex™ base sheets are clearly marked with; "HARDIETEX" NAIL AT 200mm CENTRES, SUPPORT ALL JOINTS" on the front of the sheets.		
	Mass:	7.5mm thick: 10.10kg/m ²		
	Length (mm):	Width (mm):	Thickness (mm):	
	2440	900 1200	7.5 7.5	
2725	900 1200	7.5 7.5		
3000	900 1200	7.5 7.5		

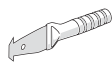
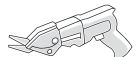
*All dimensions and masses are approximate and subject to manufacture tolerances.

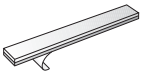
HARDIETEX™ SYSTEM COMPONENTS

	HardieDrive™ Screw 40mm long A class 3 finish self-tapping wing-tipped screw for fastening to 0.8mm to 1.6mm BMT steel frames. NOTE: Contact your fastener manufacturer for fasteners with suitable corrosion resistance.	500 Per Box Part No: 305533 For detailed information refer to Clause 2.3 Fasteners
	James Hardie™ 7.5mm PVC Starter Strip. 3,000mm long A perforated PVC extrusion, used with HardieTex™ sheet to provide a straight edge to finish the texture coating or used with PrimeLine® Newport or Summit weatherboard to secure the bottom row at the correct angle. See Figure 24 in installation manual.	25 Per Pack Part No: 305568
	HardieTex™ 7.5mm PVC Z Flashing. 3,000mm Long A PVC extrusion for use with HardieTex™ system to provide an alternative detail option at horizontal control joints.	25 Per Pack Part No: 305569
	James Hardie™ Joint Sealant. 300ml cartridge A general purpose, paintable, exterior grade polyurethane joint sealant.	20 Per Box Part No: 305534 Detailed information: refer to Figures 14, 18 – 22, 26, 27, 29 and 30
	James Hardie™ Score and Snap Knife A tungsten tipped knife for scoring fibre cement sheets.	20 Per Box Part No: 305576
	James Hardie™ Fibreshears Electric tool for cutting fibre cement sheets.	1 Each Part No: 300653
	HardieBlade™ Saw Blade. 185mm diameter A 185mm diameter poly-diamond blade for fast and clean cutting of James Hardie fibre cement.	1 Each Part No: 300660
	HardieBreak™ thermal strip A building code requirement and is installed behind James Hardie external cladding over metal framing and HardieWrap™ weather barrier. Refer to HardieBreak thermal strip installation guide. Unit size 43 x 12 x 2750mm.	45 per pack Part No. 305612
	HardieWrap™ weather barrier A non-perforated, highly breathable and reflective safe-glare weather barrier designed to be used behind HardieTex™ external cladding to help protect the building. For alternate products, please refer to HardieWrap™ weather barrier section 3.8.2. Unit size 2750mm x 30000mm.	1 each Part No. 305664

COMPONENTS NOT SUPPLIED BY JAMES HARDIE

James Hardie recommends the use of the following products in conjunction with the HardieTex™ system. James Hardie does not supply these products and does not provide a warranty for their use. Please contact the component manufacturers for information on their warranties and further information on their products.

Fibre cement nails Galvanised nails for timber NOTE: In coastal and other areas subject to salt spray, contact your fastener manufacturer for fasteners with suitable corrosion resistance	2.8 x 30mm
Buildex FibreTEKS® <small>® denotes a registered mark of Buildex</small>	40mm for 0.55 - 0.75mm BMT
PVC perforated external corner Taped and set corners - to satisfy coating manufacturer's specifications.	
Textured finish coating systems Proprietary jointing and coating systems applied in accordance with the coating manufacturer's specification by their accredited applicators. Taped and set corners when required- to satisfy coating manufacturer's specification. For detailed information on these systems refer to Sections 1- Introduction and 7- Decorative treatment NOTE: It is essential that components from different suppliers are not combined or blended, as they may not be compatible.	
Hitachi Easy Bevel attachment fitted to suitable angle grinder, with dust extraction apparatus fitted.	

9 DETAILS

9.1 GENERAL

Various details are outlined below and are also available in CAD format at www.accel.com.au

All dimensions are in millimetres unless shown otherwise

9.2 SLAB ON GROUND AND PLATFORM FLOORS

9.2.1 General

The slab and footings on which the building is situated must comply with AS 2870 'Residential slabs and footings - Construction' and the requirements of the Building Code of Australia (BCA).

Install James Hardie external cladding with a minimum 150mm clearance to the earth on the exterior of the building or in accordance with local building codes if greater than 150mm is required.

Maintain a minimum 50mm clearance between James Hardie external cladding and roofs, decks, paths, steps and driveways.

Adjacent finished grade must slope away from the building in accordance with local building codes, typically a minimum slope of 50mm minimum over the first metre.

Do not install external cladding such that it may remain in contact with standing water.

NOTE

Greater clearance may be required in order to comply with termite protection provisions.

The BCA specifies the requirements for termite barriers and must be complied with. Where the exposed slab edge is used as part of the termite barrier system, a minimum of 75mm of the exposed slab edge must be visible to permit ready detection of termite entry.

9.2.2 Slab on ground

For detail at slab on ground edge refer to Figure 24.

9.2.3 Platform floors

For platform floors, HardieTex™ system can be used to infill between the floor and the ground, eg on stepped or sloping sites. Refer to Figure 25 as an illustration only.

Ensure sheets are clear of the ground by finishing to a formed masonry kerb, etc or provide a gap. Where masonry plinths are offset outward, use flashing to prevent water ponding at the sheet edge.

Ventilation to the floor space can be provided by a gap at the base of sheets to the ground or by installing wall vents. Ensure adequate sub-floor ventilation is provided around the perimeter of the platform floor.

9.3 WINDOWS

For sheet layout around window openings refer to Figure 15.

For typical aluminium and timber framed window fixing details, refer to Figures 26, 27, 28.

Refer to window manufacturer for appropriate installation and flashing details. Ensure flashing is installed correctly to facilitate water escape from window frames.

Figure 26 includes optional decorative trim that can be used to create a sense of depth around windows just like a rendered masonry wall. Refer to Section 7 for further information on decorative trims.

9.4 EAVES LINING

The HardieTex™ system can stop at the eaves lining (See Figure 29), or alternatively run through to the top plate so as to provide bracing capacity for the wall (See Figure 30).

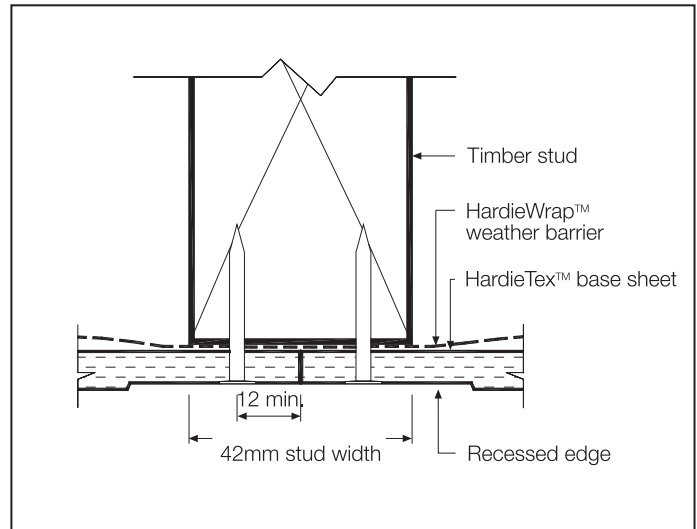

FIGURE 1 SINGLE TIMBER STUD

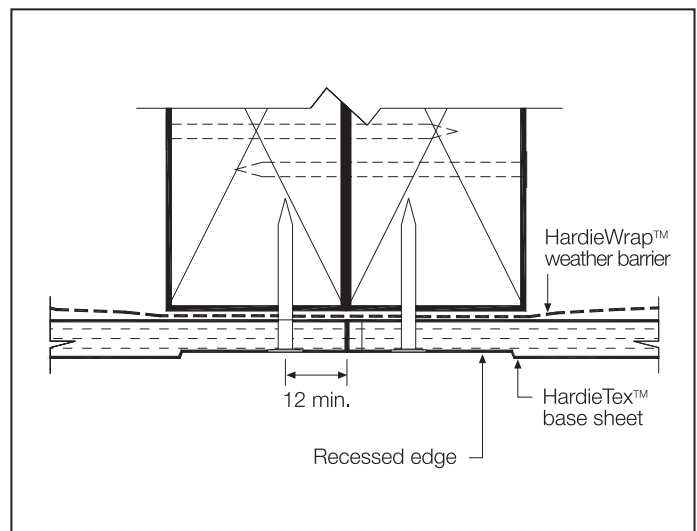

FIGURE 2 DOUBLE TIMBER STUD

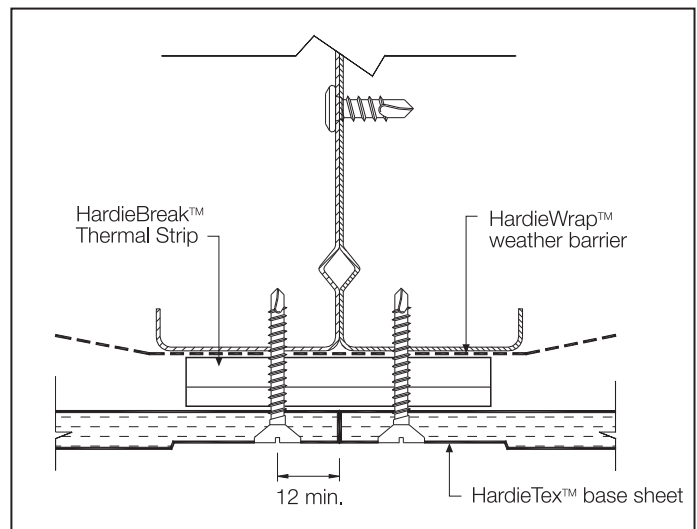

FIGURE 3 DOUBLE STEEL STUD

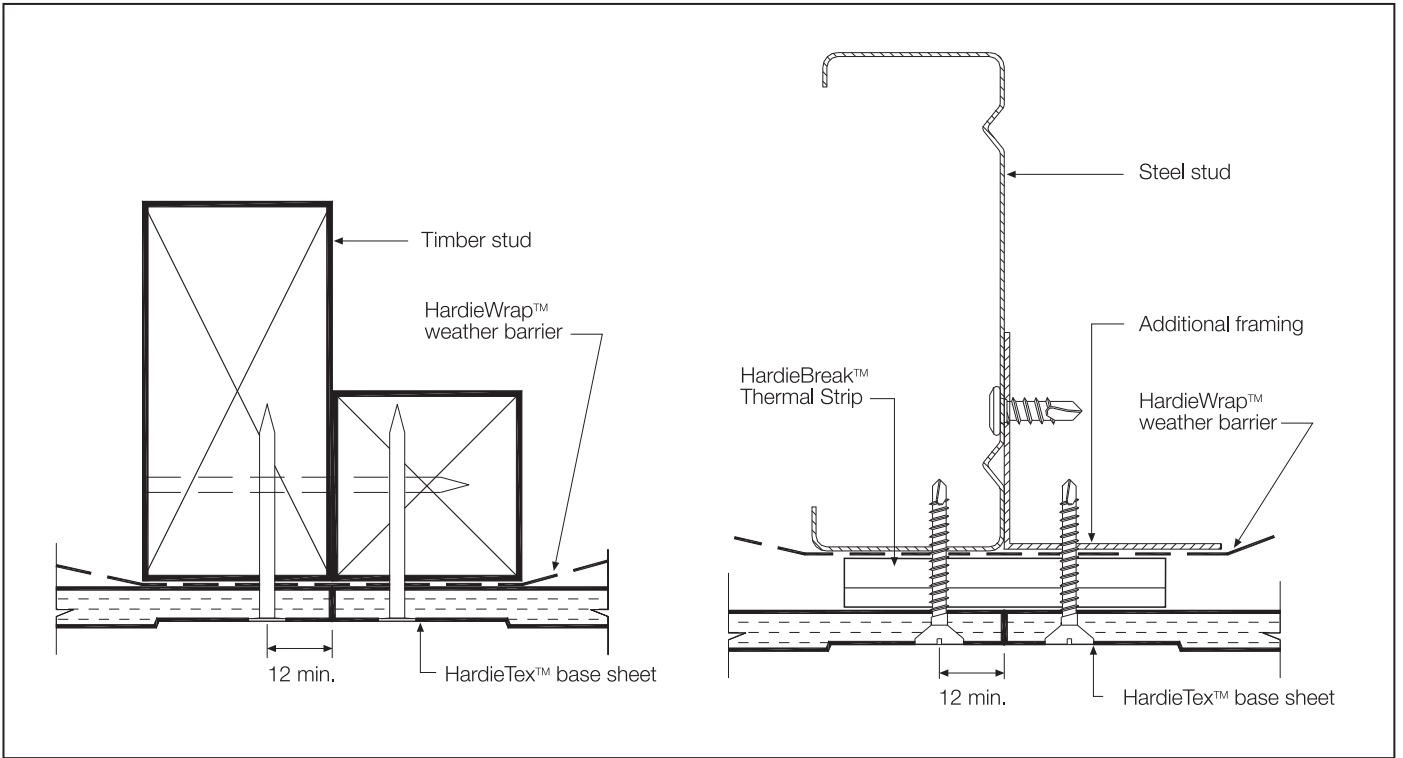

FIGURE 4 ADDITIONAL FRAMING FOR SHEET EDGE SUPPORT

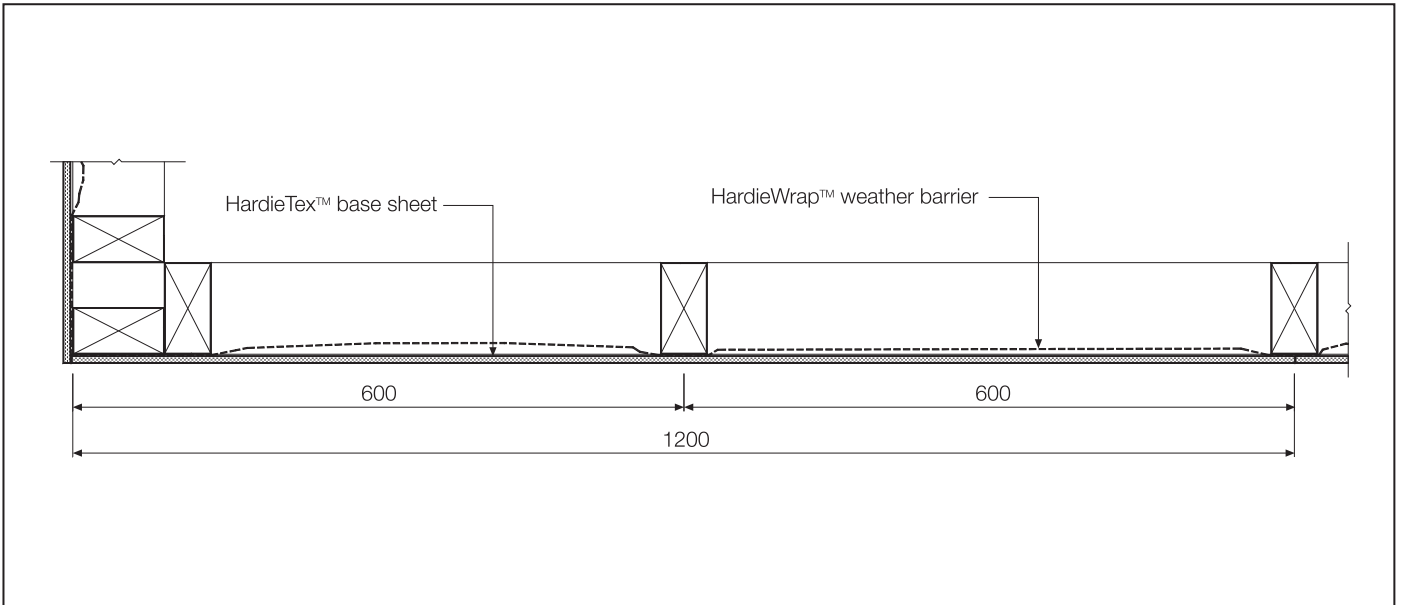

FIGURE 5 TIMBER FRAMING STUD SET OUT

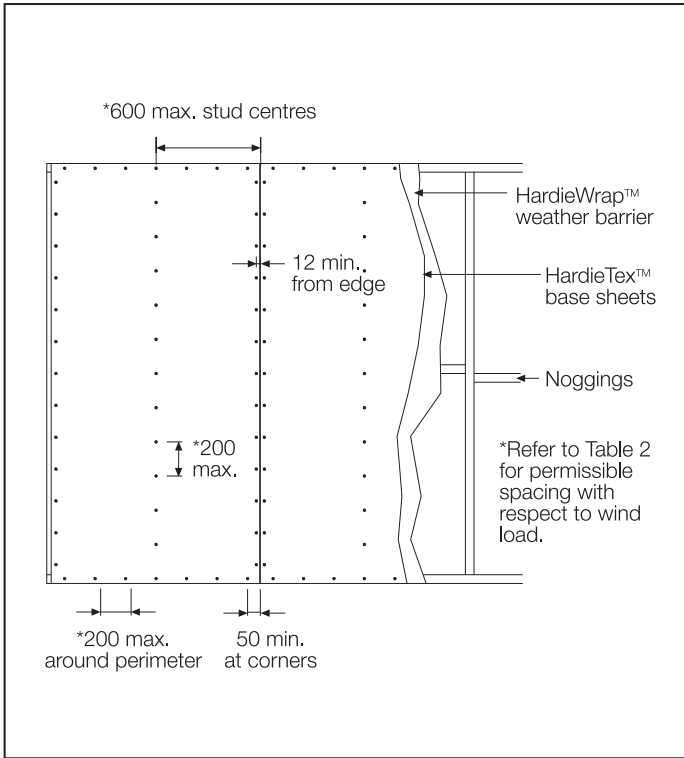

FIGURE 6 VERTICAL SHEET FIXING

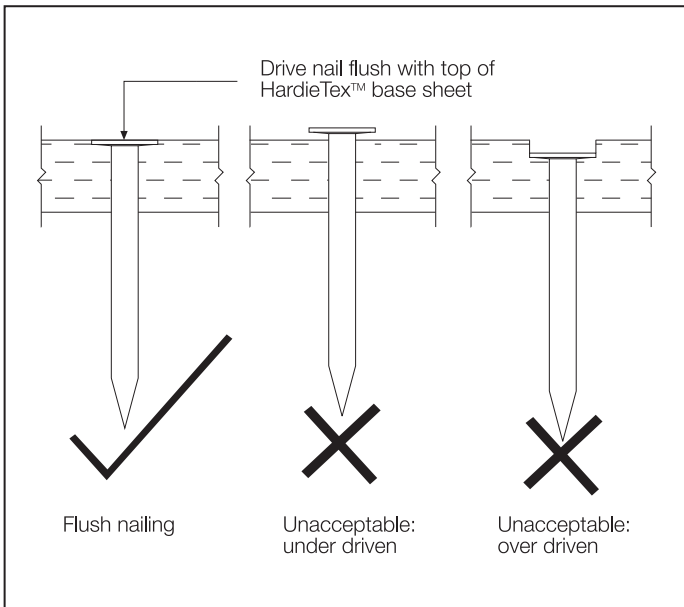

FIGURE 7 NAIL FASTENER DEPTH

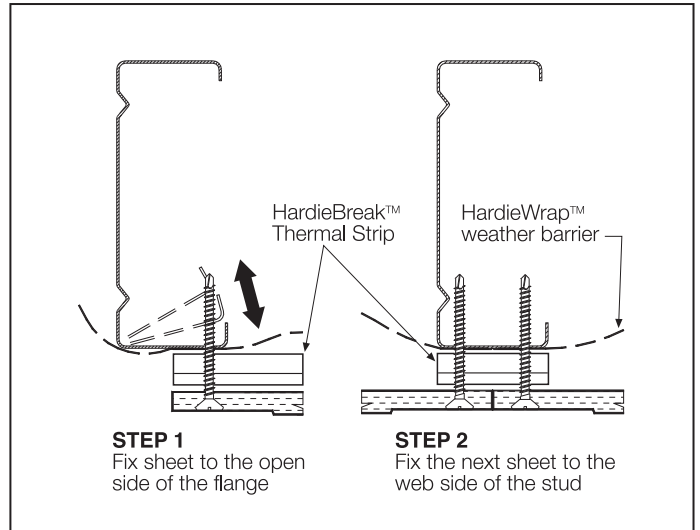

FIGURE 8 SCREW FASTENING

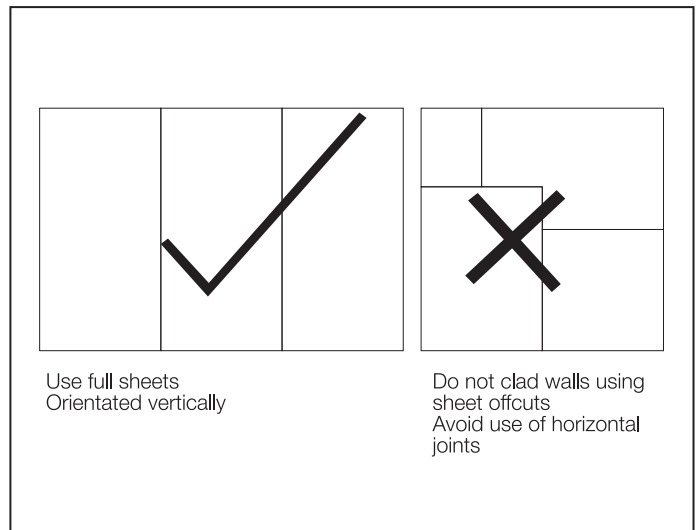

FIGURE 9 USE FULL SHEETS

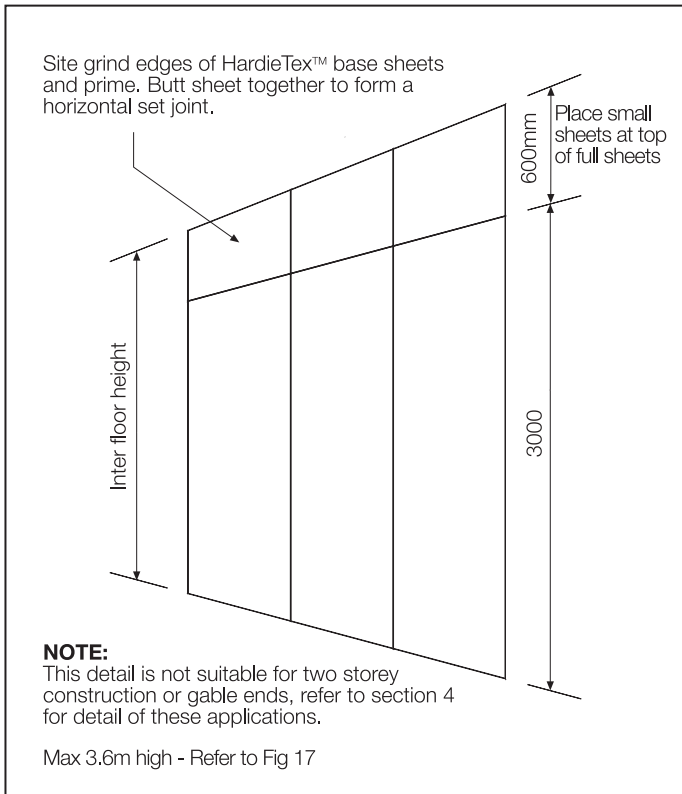

FIGURE 10 PLACE SMALL SHEETS ON TOP

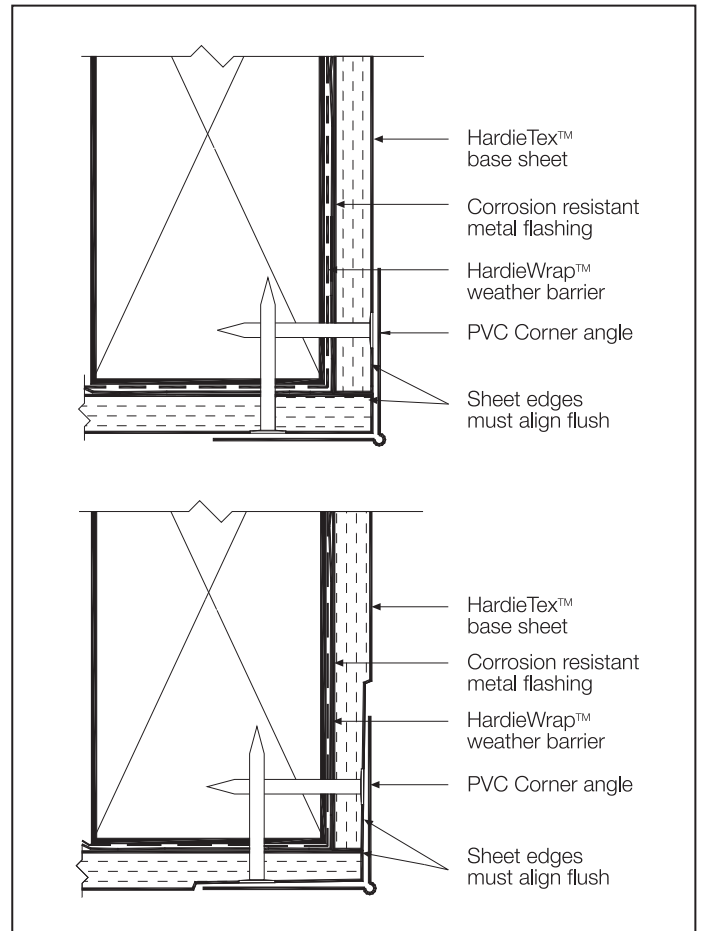

FIGURE 13 EXTERNAL CORNER OPTION 1 AND 2

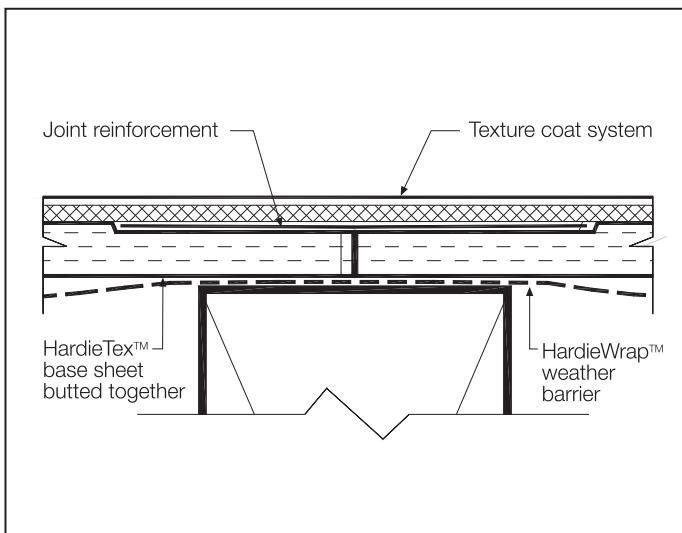

FIGURE 11 FLUSH SET JOINT

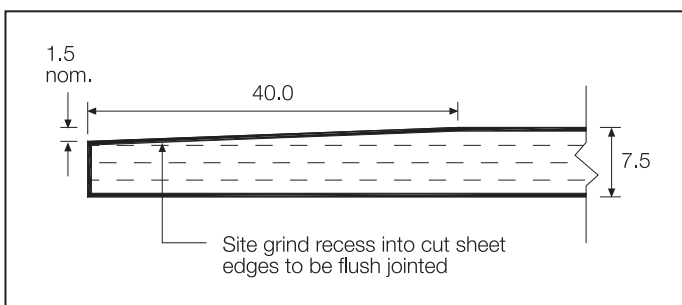

FIGURE 12 SITE GROUND RECESSED EDGE DETAIL

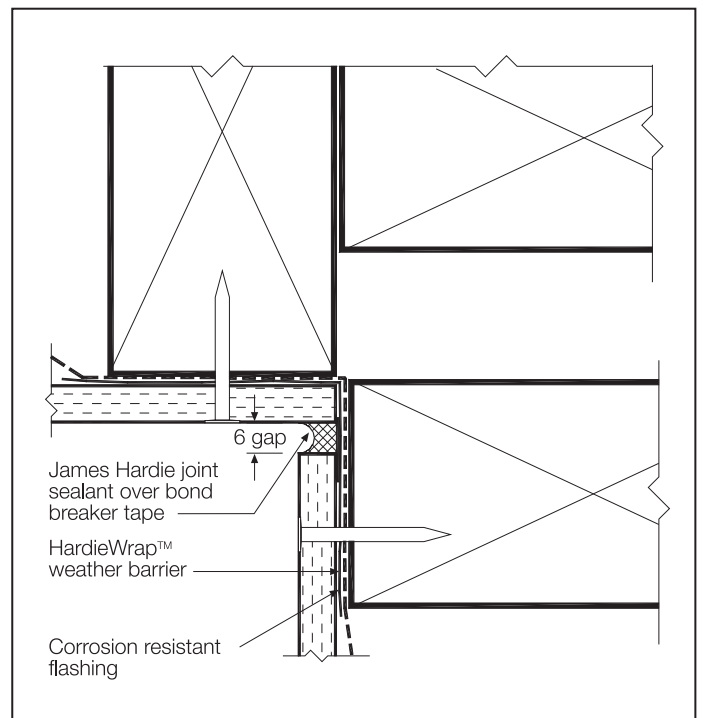

FIGURE 14 INTERNAL CORNER

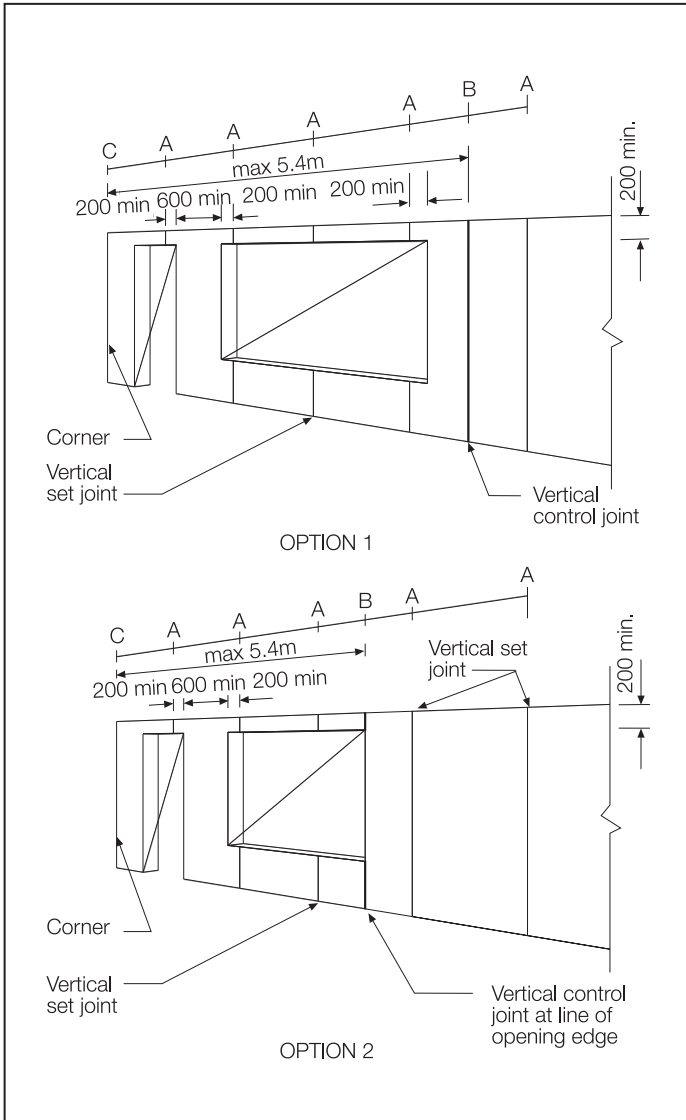

FIGURE 15 SHEET LAYOUT AROUND OPENINGS

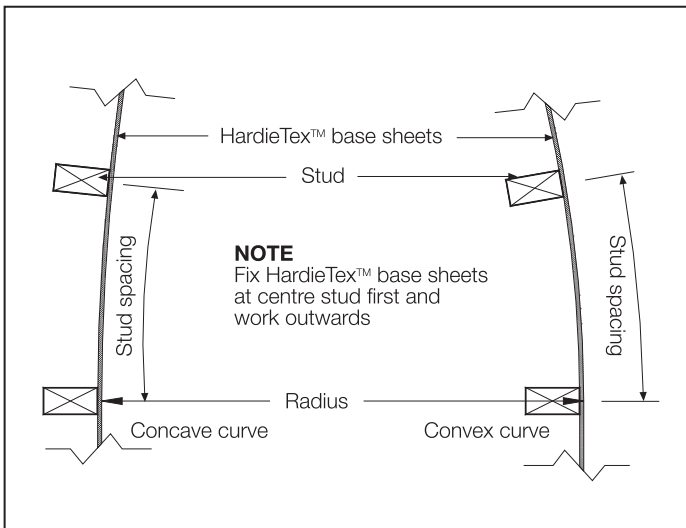

FIGURE 16 CURVED WALLS

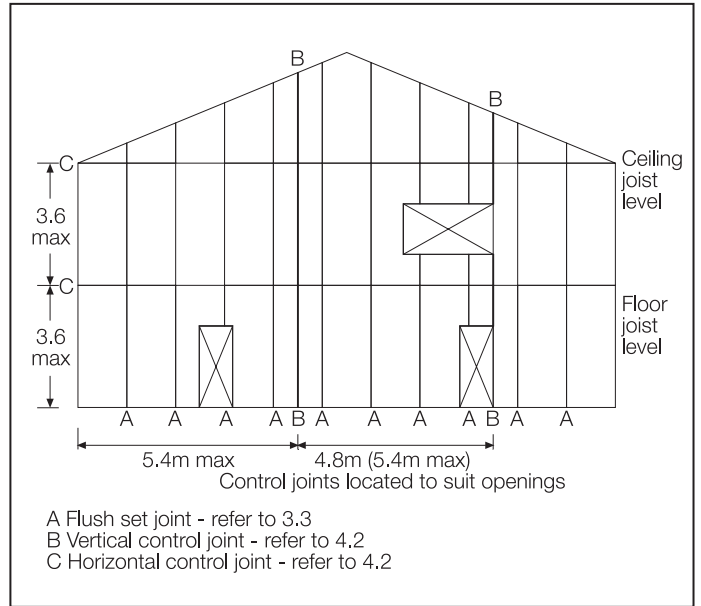

FIGURE 17 AN EXAMPLE OF CONTROL JOINT LAYOUT

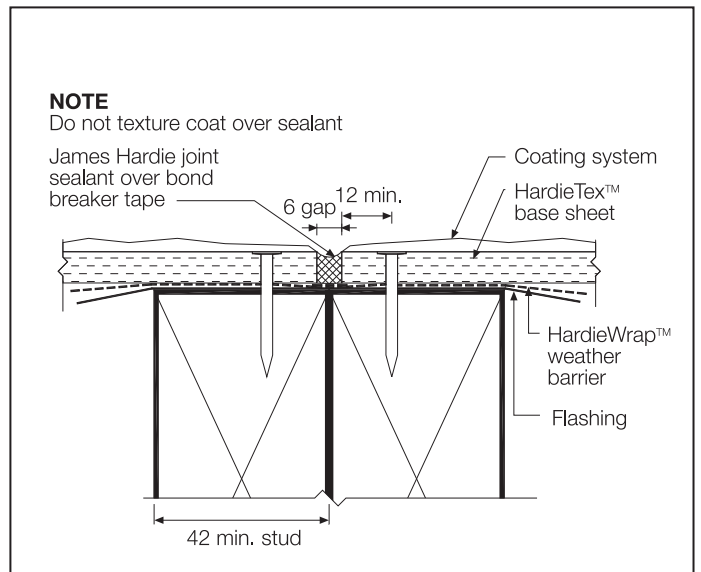

FIGURE 18 VERTICAL CONTROL JOINTS

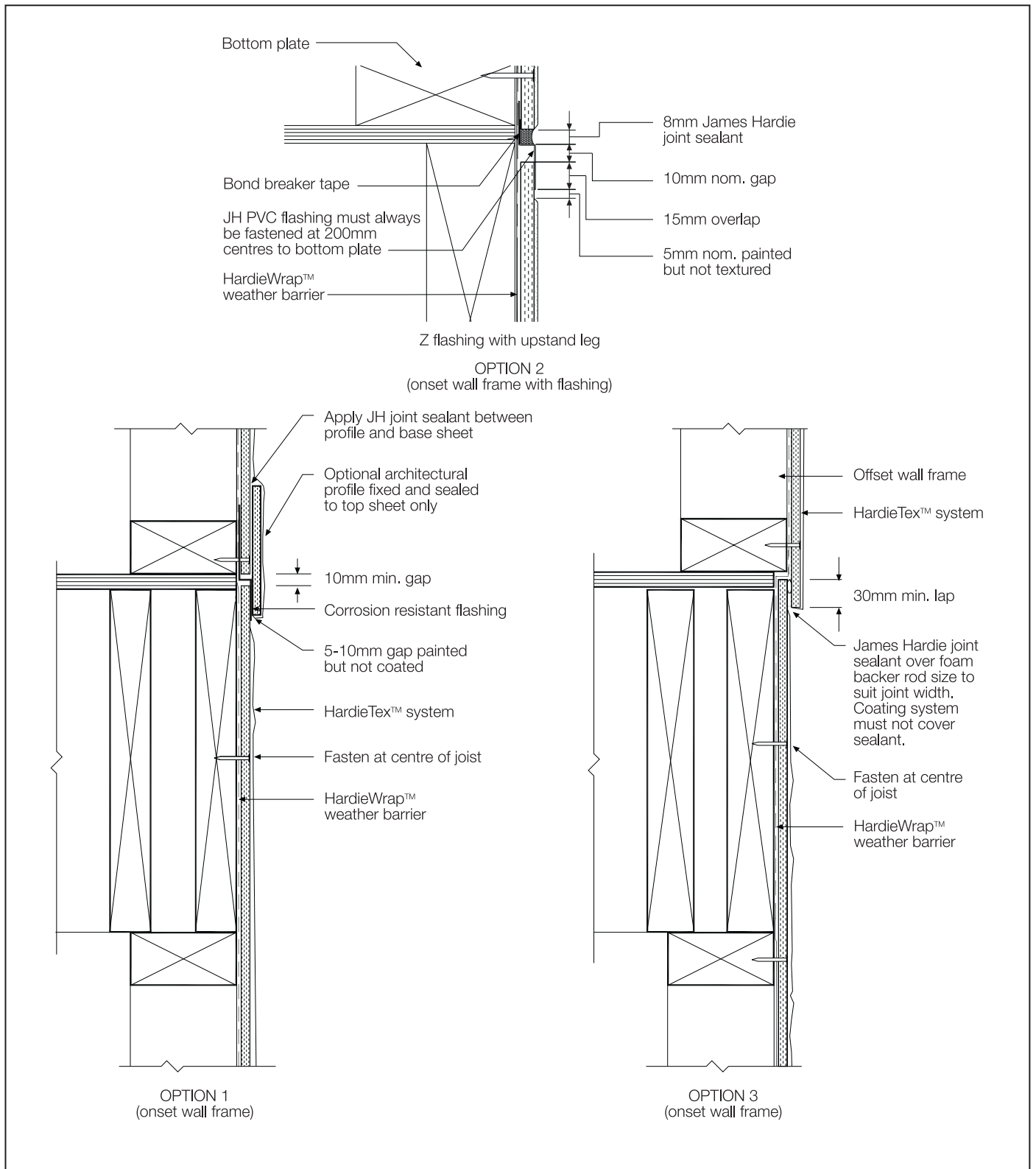

FIGURE 19 HORIZONTAL CONTROL JOINT - FLOOR JUNCTION OF A TWO STOREY HARDIETEX WALL

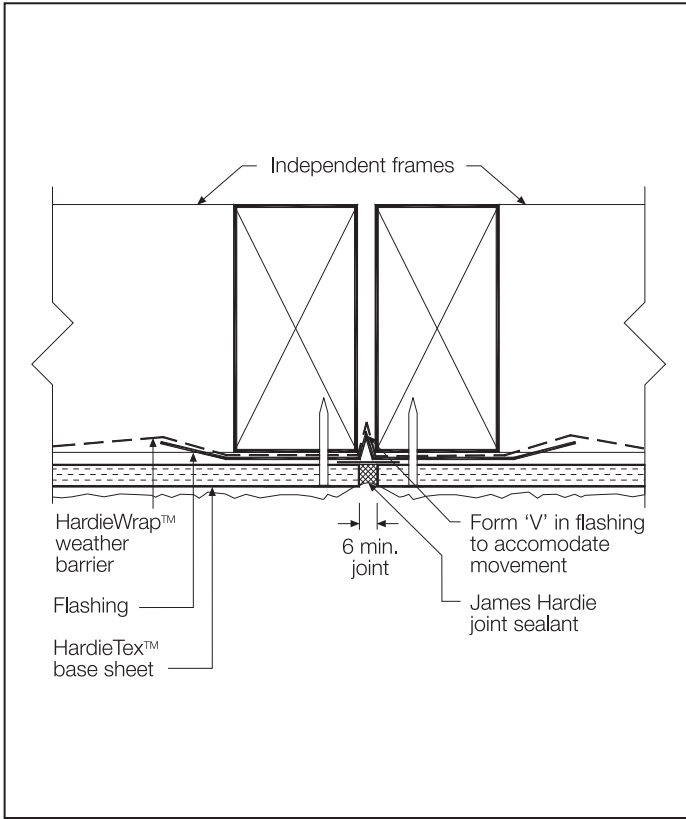

FIGURE 20 VERTICAL MOVEMENT JOINT IN HARDIETEX WALL (CONTROL JOINT REQUIRED BY DESIGN)

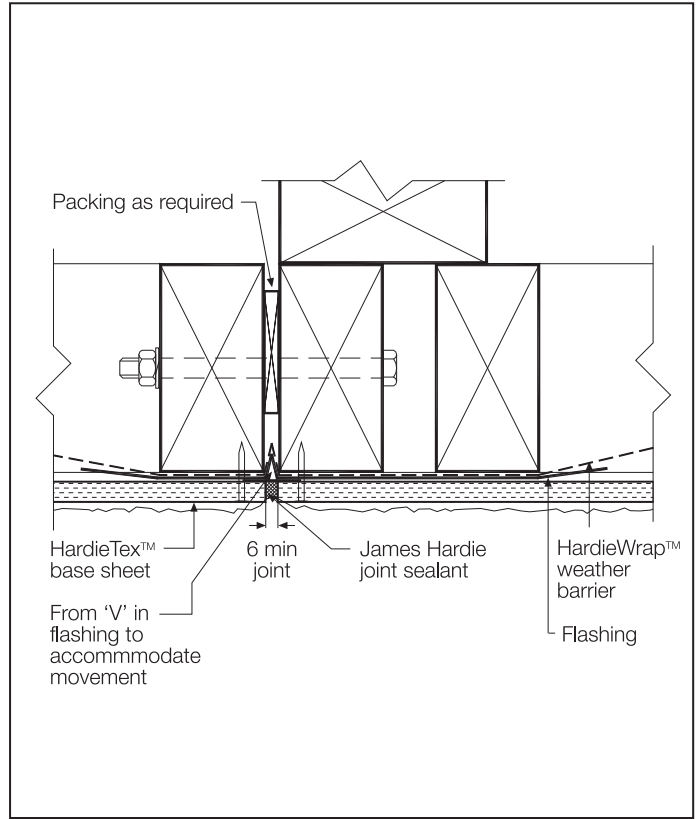

FIGURE 22 VERTICAL MOVEMENT JOINT - INTERSECTION WITH EXISTING CLAD STRUCTURE

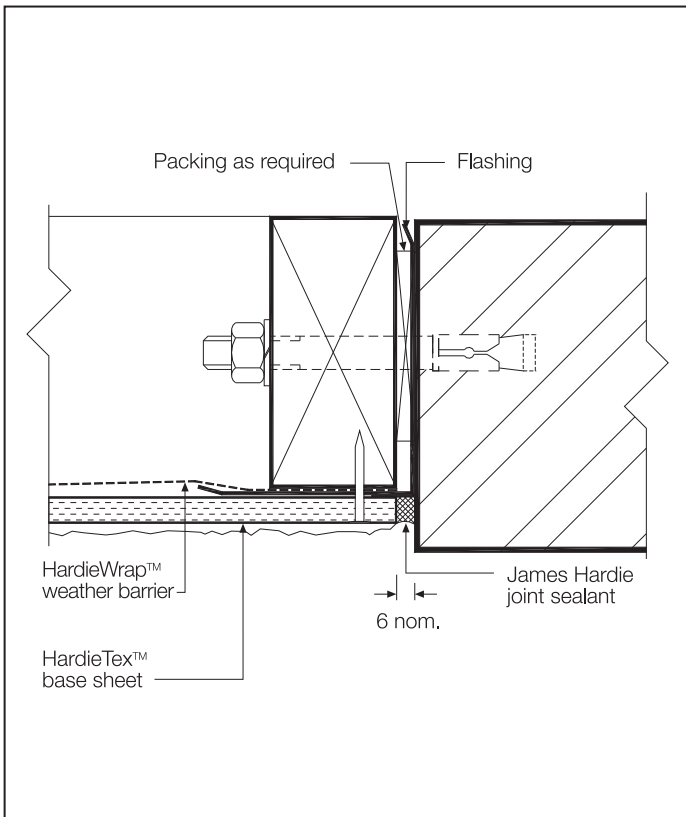

FIGURE 21 VERTICAL MOVEMENT JOINT - INTERSECTION WITH MASONRY STRUCTURE

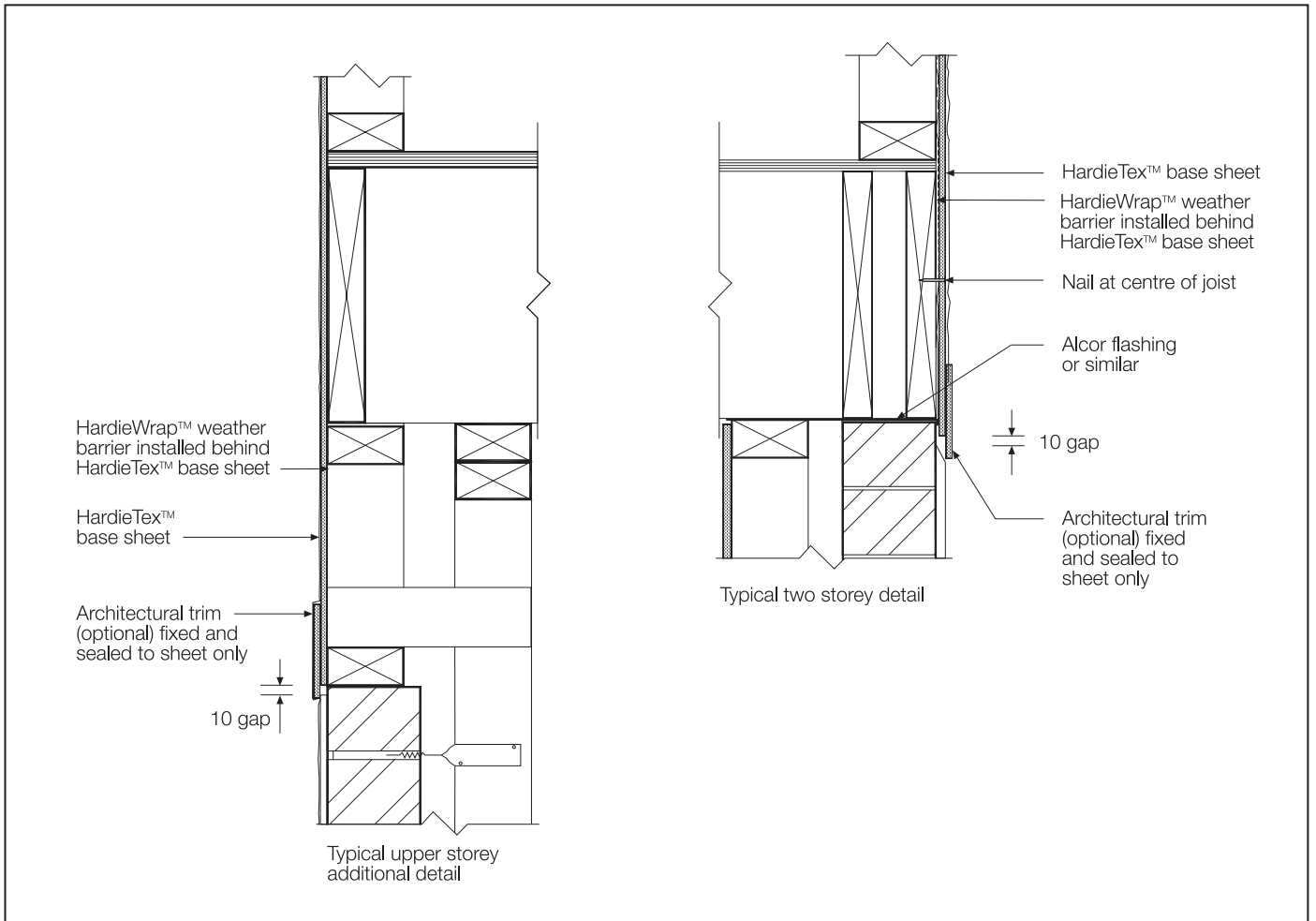

FIGURE 23 HORIZONTAL MOVEMENT JOINT - FLOOR JUNCTION WITH MASONRY GROUND FLOOR

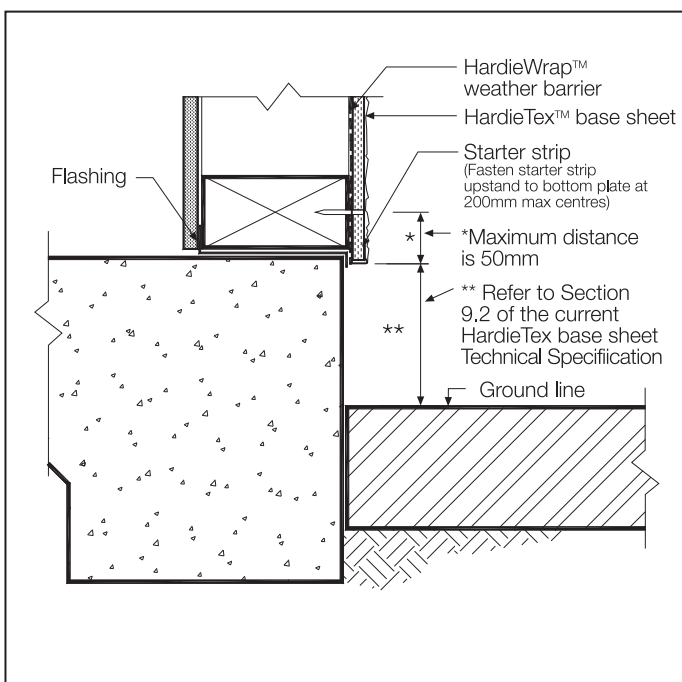

FIGURE 24 SLAB EDGE DETAIL

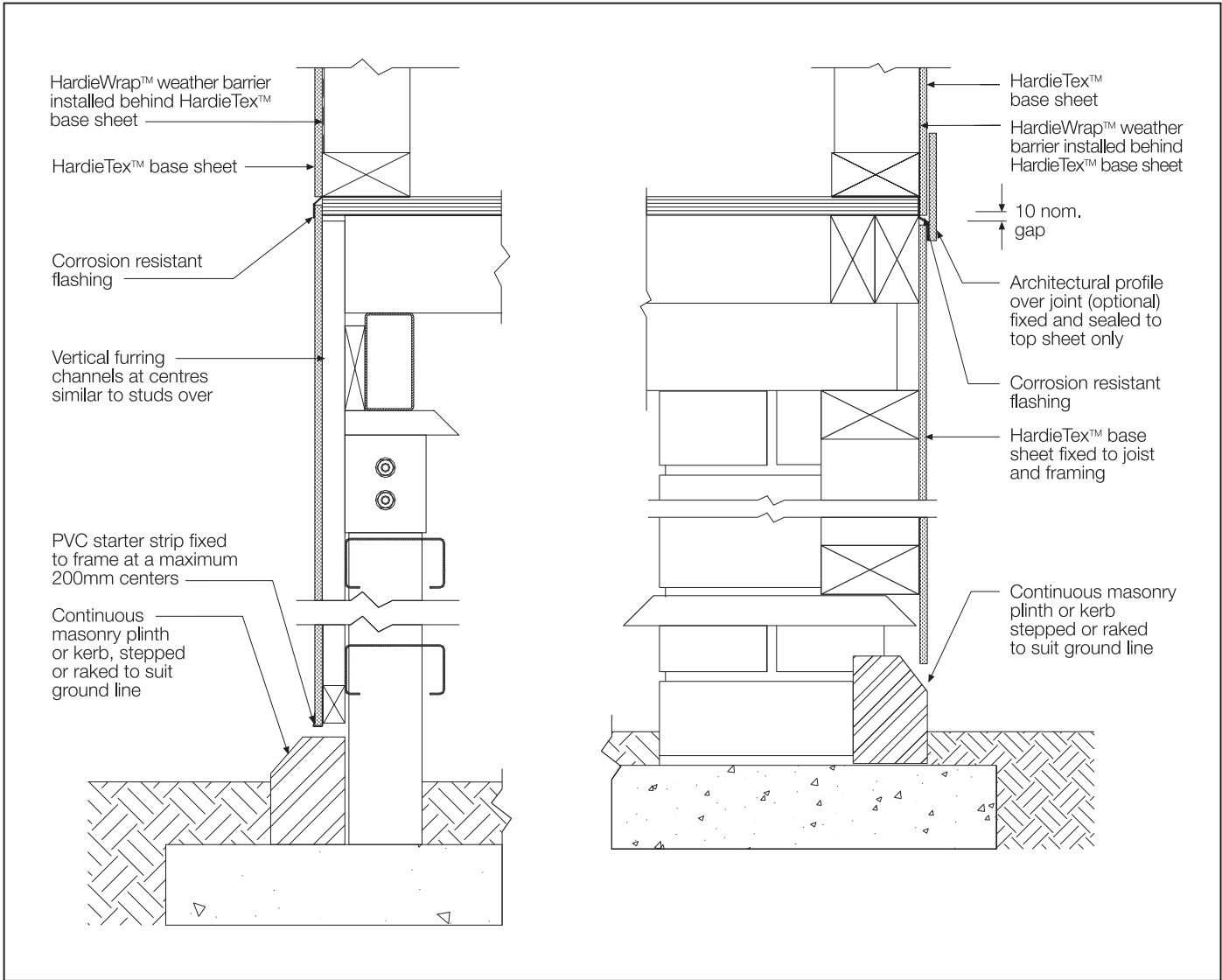

FIGURE 25 PLATFORM FLOOR DETAIL

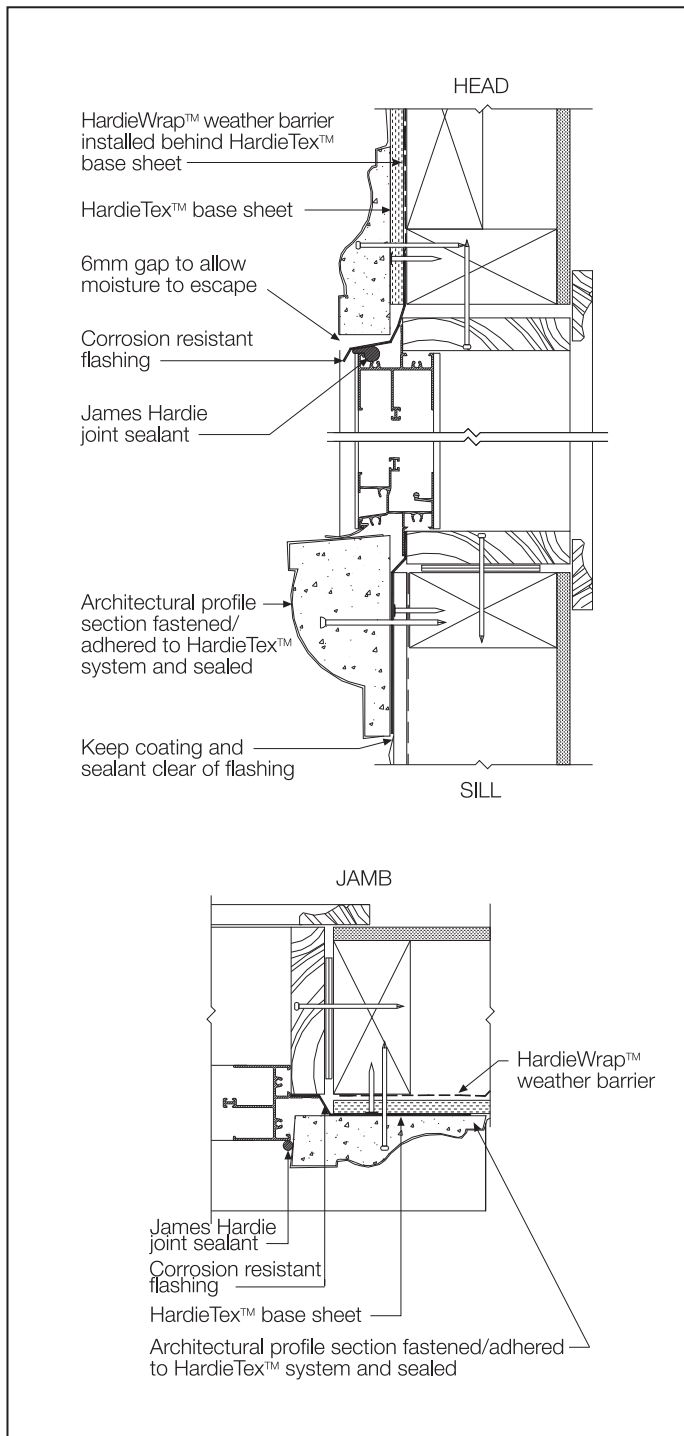

FIGURE 26 ALUMINIUM WINDOW DETAILS - WITH DECORATIVE TRIM

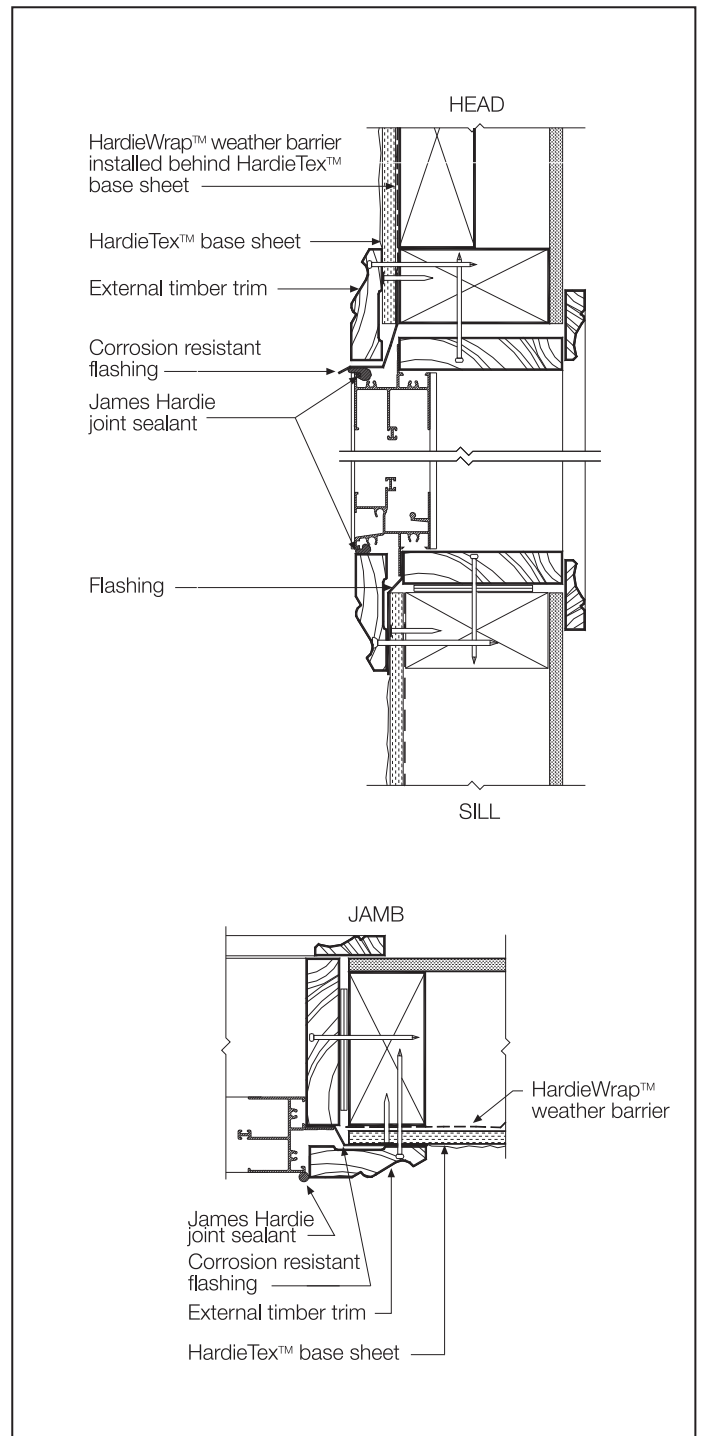

FIGURE 27 ALUMINIUM WINDOW DETAILS - WITH TIMBER TRIM

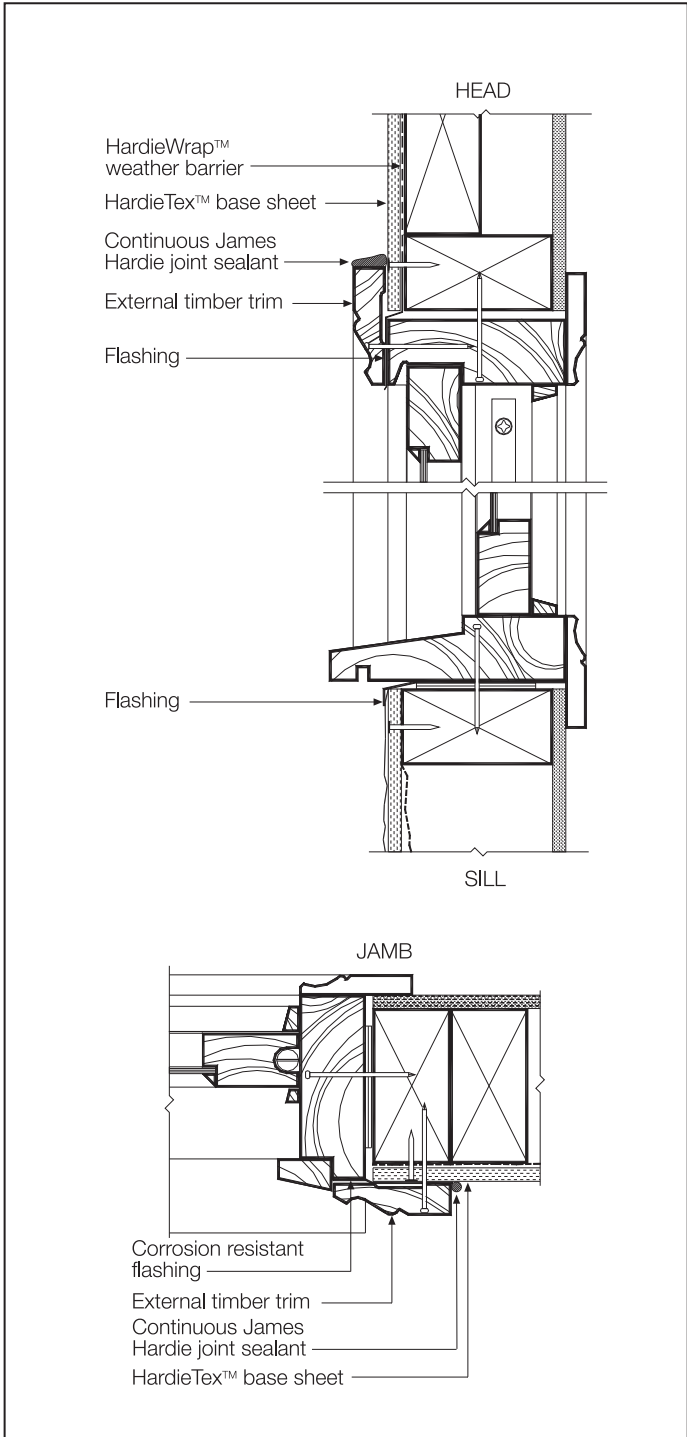

FIGURE 28 TIMBER WINDOW DETAILS - WITH TIMBER TRIM

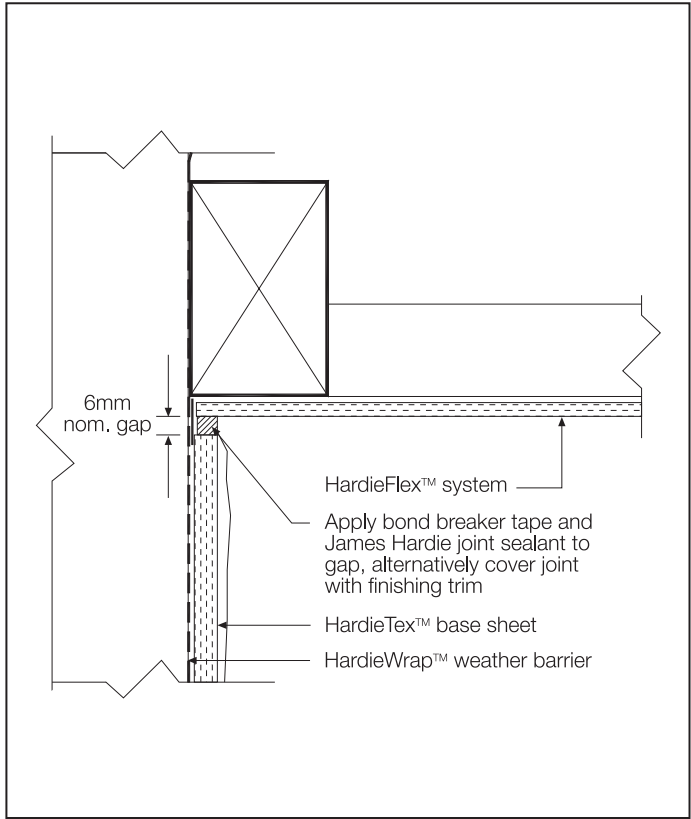

FIGURE 29 HARDIETEX SYSTEM STOPS AT EAVES LINING

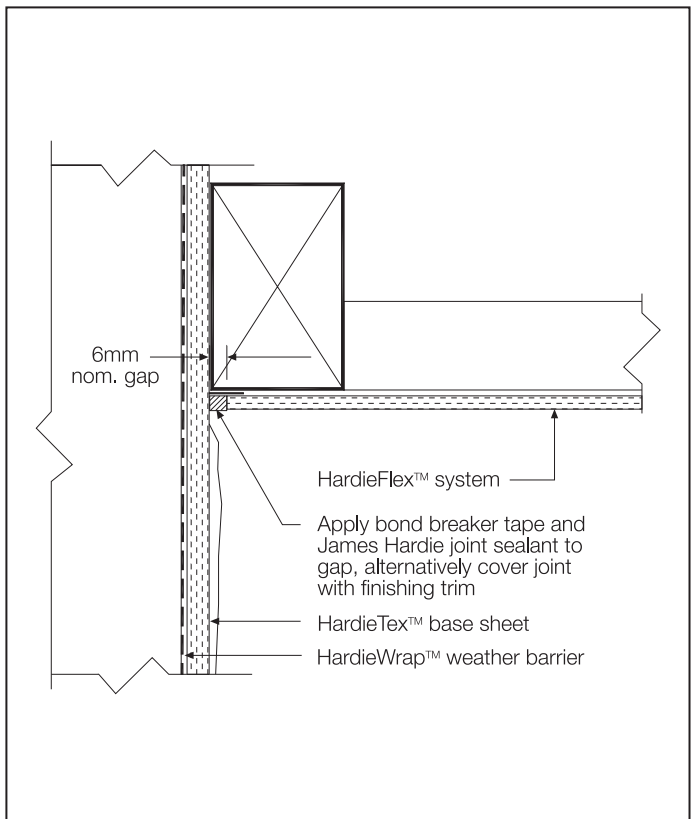

FIGURE 30 HARDIETEX SYSTEM CONTINUES PAST EAVES LINING

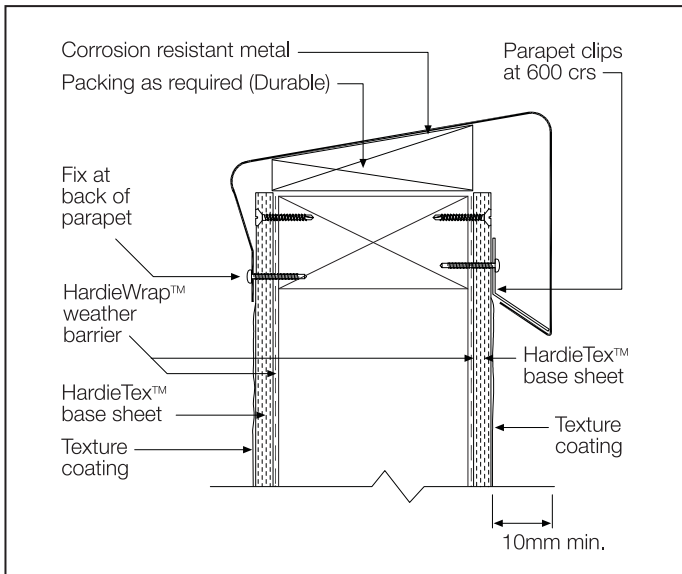

FIGURE 31 PARAPET CAPPING

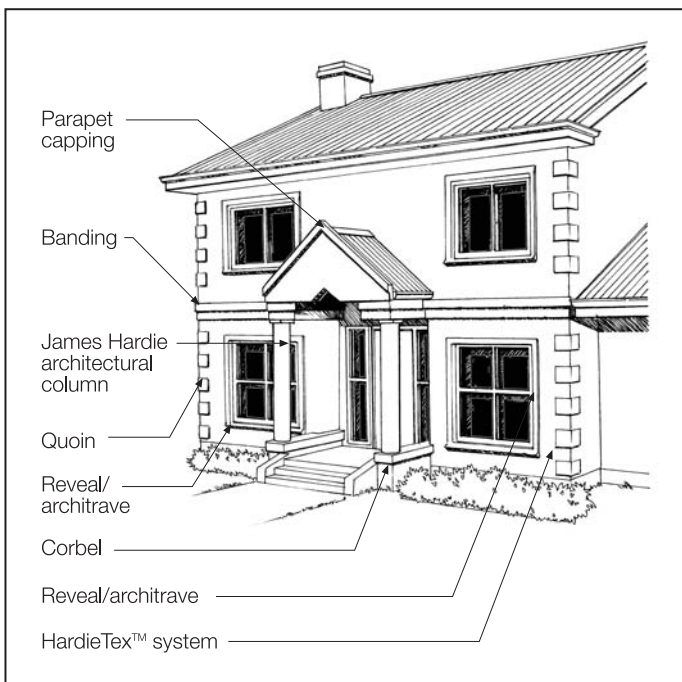

FIGURE 32 EXAMPLE OF USE OF DECORATIVE TREATMENTS

10 WARRANTY

HardieTex™ base sheet

10 Year Warranty

January 2012

James Hardie Australia Pty Limited ("James Hardie") warrants to the first purchaser of HardieTex™ base sheet (**Product**) from James Hardie and the last purchaser of the Product prior to installation that, subject to compliance with the Conditions of Warranty below:

- for a period of 10 years from the date of purchase, the Product will be free from defects due to defective factory workmanship or materials; and
- for a period of 10 years from the date of purchase, the Product will be resistant to damage from cracking, moisture, rotting, fire and termites to the extent set out in James Hardie's relevant published literature current at the time of installation; and
- for a period of 12 months from the date of purchase that the accessories supplied by James Hardie will be free from defects due to defective factory workmanship or materials.

For the purposes of this warranty, a "defect" in respect of the Product means a non-compliance with AS/NZS 2908.2:2000 Cellulose-cement products - Flat sheet.

CONDITIONS OF WARRANTY

This warranty is strictly subject to the following conditions:

- (a) James Hardie will not be liable for breach of this warranty unless the claimant provides proof of purchase of the Product and makes a written claim to James Hardie at the address set out below, either within 30 days after the defect would have become reasonably apparent or, if the defect was reasonably apparent prior to installation, then the claim must be made prior to installation.
- (b) the Product is subject to natural variation in finish as part of the manufacturing process. The builder/installer must ensure the Product meets aesthetic requirements before installation. Subject to the terms of this warranty, after installation of the Product, James Hardie is not liable for claims arising from aesthetic surface variations if such variations were, or would upon reasonable inspection have been, apparent prior to installation;
- (c) this warranty cannot be relied upon by any other person and is not transferable;
- (d) the Product must be installed and maintained strictly in accordance with the relevant James Hardie literature current at the time of installation and must be installed in conjunction with the components or products specified in the literature. To obtain copies of such literature go to or contact Ask James Hardie™ on 13 11 03. Further, all other products, including coating and jointing systems, applied to or used in conjunction with the Product must be applied or installed and maintained strictly in accordance with the relevant manufacturer's instructions and good trade practice;
- (e) the project must be designed and constructed in strict compliance with all relevant provisions of the current Building Code of Australia, regulations and standards;
- (f) if the claimant chooses to rely upon this warranty then the claimant's sole remedy under this warranty for breach of this warranty is (at James Hardie's option) that James Hardie will either supply replacement Product, rectify the affected Product or pay for the cost of the replacement or rectification of the affected Product;
- (g) In the circumstances where the Australian Consumer Law does not apply in respect of the purchase of the Product, James Hardie will not be liable for any losses or damages (whether direct or indirect) including property damage or personal injury, consequential loss, economic loss or loss of profits, arising in contract or negligence or howsoever arising. Without limiting the foregoing, James Hardie will not be liable for any claims, damages or defects arising from or in

any way attributable to poor workmanship, poor design or detailing, settlement or structural movement and/or movement of materials to which the Product is attached, incorrect design of the structure, acts of God including but not limited to earthquakes, cyclones, floods or other severe weather conditions or unusual climatic conditions, efflorescence or performance of paint/coatings applied to the Product, normal wear and tear, growth of mould, mildew, fungi, bacteria, or any organism on any Product surface or Product (whether on the exposed or unexposed surfaces);

- (h) In the circumstances where the Australian Consumer Law does not apply in respect of the purchase of the Product, all warranties, conditions, liabilities and obligations other than those specified in this warranty are excluded to the fullest extent allowed by law;
- (i) If meeting a claim under this warranty involves re-coating of Product, there may be slight colour differences between the original and replacement Product due to the effects of weathering and variations in materials over time and James Hardie is not liable for any such colour differences;
- (j) In the circumstances where the Australian Consumer Law does not apply in respect of the purchase of the Product and therefore to this warranty, all expenses incurred as a result of claiming under this warranty are to be borne by the claimant.
- (k) In the circumstances where the Australian Consumer Law does apply in respect of the purchase of the Product and therefore to this warranty, if James Hardie accepts or it is determined by James Hardie that the claimant has a valid claim under this warranty, James Hardie will bear the claimant's reasonable costs of claiming under this warranty. The claimant is responsible for all other costs of claiming under this warranty. All claims for such costs are to be notified to James Hardie at the address outlined below within 21 days from when the claimant first makes a claim under this warranty.

DISCLAIMER

The recommendations in James Hardie's literature are based on good building practice but are not an exhaustive statement of all relevant information and are subject to conditions (d), (e), (g) and (h) above. Further, as the successful performance of the relevant system depends on numerous factors outside the control of James Hardie (e.g. quality of workmanship and design), James Hardie shall not be liable for the recommendations in that literature and the performance of the relevant system, including its suitability for any purpose or ability to satisfy the relevant provisions of the Building Code of Australia, regulations and standards.

IMPORTANT NOTE

If you acquire goods manufactured by James Hardie as a consumer according to the Australian Consumer Law, our goods come with guarantees that cannot be excluded under the Australian Consumer Law. You are entitled to a replacement or refund for a major failure and compensation for any other reasonably foreseeable loss or damage. You are also entitled to have the goods repaired or replaced if the goods fail to be of acceptable quality and the failure does not amount to a major failure.

Any rights a consumer may have under this warranty are in addition to other rights and remedies of a consumer under a law in relation to the goods to which this warranty relates. Nothing in this document shall exclude or modify any legal rights a customer may have under the Australian Consumer Law or otherwise which cannot be excluded or modified at law.

Contact details if you wish to make a claim under this warranty: For more information or to make a claim under this warranty please Ask James Hardie™ on 13 11 03, visit www.jameshardie.com.au or www.accel.com.au, email James Hardie via our website or write to James Hardie at:

James Hardie Australia Pty Ltd
10 Colquhoun Street Rosehill NSW 2142
PO Box 70 Parramatta NSW 2124

© Copyright 2012 James Hardie Australia Pty Ltd. ABN 12 084 635 558.™ and ® denotes a trademark or registered mark owned by James Hardie Technology Limited

NOTES

Ask James Hardie™
Call 13 11 03
www.jameshardie.com.au