

# COMPACT WORKBENCH

## 1405H x 1100W x 530Dmm POWDER COATED

### Very Important!

Unpack the unit and confirm that you have all the parts listed. Assemble the unit on a solid level surface, avoid carpet. You will need the assistance of a second person during assembly. You will need the following: Rubber Mallet or Hammer and Screwdriver.

**Note:** Do not place additional MDF boards on shelving brackets until completion of shelving unit!

### SAFETY TIP:

When assembling or installing this product wear protective gloves and eyewear.

### Parts List

	Front Leg 'A'	X 2
	Back Leg Left 'B'	X 1
	Back Leg Right 'C'	X 1
	Long Bracket 'D'	X 4
	Short Bracket 'E'	X 4
	Middle Brace 'F'	X 4
	Peg Board Frame Left 'G'	X 1
	Peg Board Frame Right 'H'	X 1
	Tool Tray 'I'	X 1
	Tool Tray Bracket Left 'J'	X 1
	Tool Tray Bracket Right 'K'	X 1
	Peg Board 'L'	X 1
	Bench Top 'M'	X 1
	Bottom Shelf 'N'	X 1
	Peg Board Hooks	X 20
	Foot Caps	X 4
	Phillips Head Bolts M6*15mm	X 11
	Hex Nuts M6	X 9

NOT TO SCALE

### Step 1

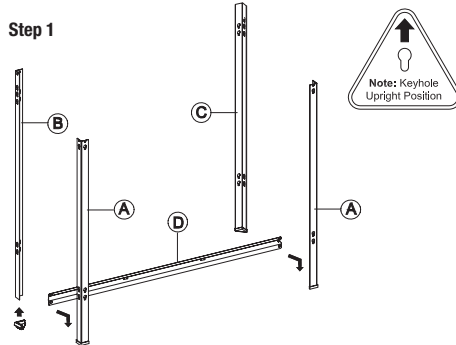

Place foot end caps onto the bottom of the legs 'A', 'B' and 'C'. Note upright position. Place shelving brackets 'D' onto the legs. A rubber mallet can be used to lightly tap all brackets into the keyholes of the legs into place.

### Step 2

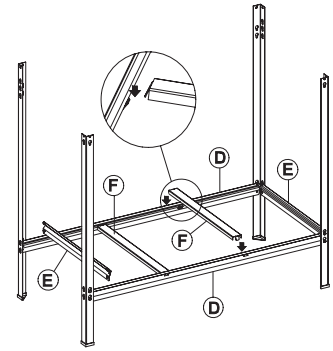

Place side brackets 'E' as shown in the diagram, followed by braces 'F' as shown.

### Step 3

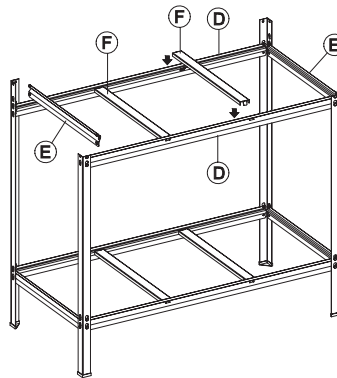

Repeat Step 2 for the bench top.

### Step 4

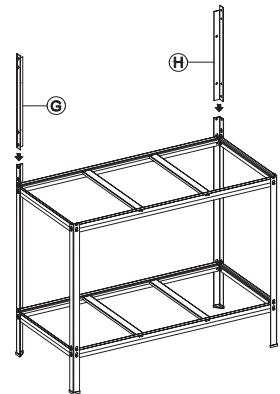

Join the pegboard frame 'G' and 'H' as shown in the diagram. Note upright position.

### Step 5

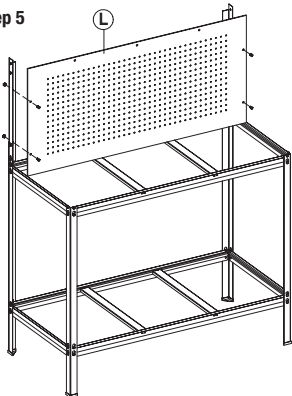

Put pegboard 'L' in place and fasten nut and bolts. Once in place tighten nuts and bolts.

### Step 6

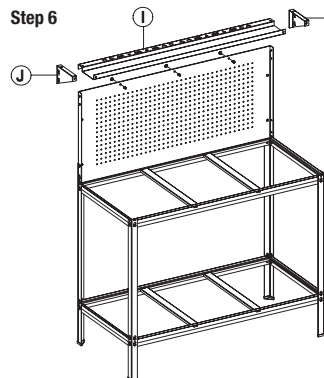

Place tool tray 'I' against the pegboard and secure with bracket 'J' and 'K'.

### Step 7

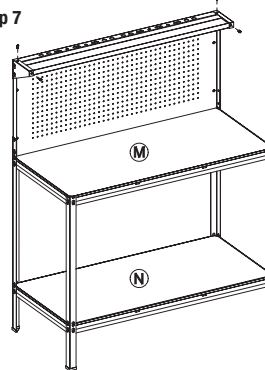

Fasten brackets onto tool tray with the supplied bolts and place bottom shelf 'N' followed by bench top 'M'.

### Step 8

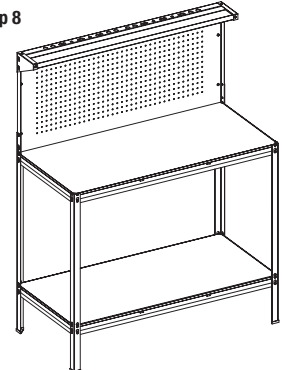

Ensure all bolts are fastened for safety.

### WARRANTY CONDITIONS

Any claim under this warranty must be made within 1 year of the date of purchase of the product. To make a claim under the warranty, take the product (with proof of purchase) to any Bunnings store (see [www.bunnings.com.au](http://www.bunnings.com.au) for store locations). Romak Hardware Distributors Pty Ltd bears reasonable, direct, expenses of claiming under the warranty. You may submit details and proof to our store for consideration. The warranty covers manufacturer defects in materials, workmanship and finish under normal use. This warranty is provided in addition to other rights and remedies you may have under law: our goods come with guarantees which cannot be excluded under the Australian Consumer Law. You are entitled to replacement or refund for a major failure and compensation for other reasonably foreseeable loss or damage. You are also entitled to have the goods repaired or replaced if the goods fail to be of acceptable quality and the failure does not amount to a major failure. The warranty excludes damage resulting from product misuse or product neglect. The warranty covers domestic use only and does not apply to commercial applications. This warranty is given by Romak Hardware Distributors Pty Ltd, ABN 15489950457, 177-181 Atlantic Drive, Keilorborough Vic 3173, (03) 9795-6789, E-mail: [sales@romak.com.au](mailto:sales@romak.com.au). New Zealand customers please contact HARCO (Harkness & Young Ltd), 9 27 64071, Email: [sales@harknessyoung.co.nz](mailto:sales@harknessyoung.co.nz). 'Romak' is a TM. © Romak. Suitable for model number 90017.