



HERITAGE RANGE MODULAR GARDEN BED

SM : 800_{mm} (L) 800_{mm} (W) 300_{mm} (H)

LG : 1200_{mm} (L) 1200_{mm} (W) 300_{mm} (H)

IMPORTANT

This heritage timber bed is manufactured from the highest quality cypress heartwood. To prevent discolouration over time it is recommended that once assembled the external surfaces are coated with a quality natural oil or stain.

Before filling the bed with soil, ensure it is square and level.

Be aware that this timber product may splinter so it is recommended that protective gloves are worn during assembly.

KIT CONTENTS

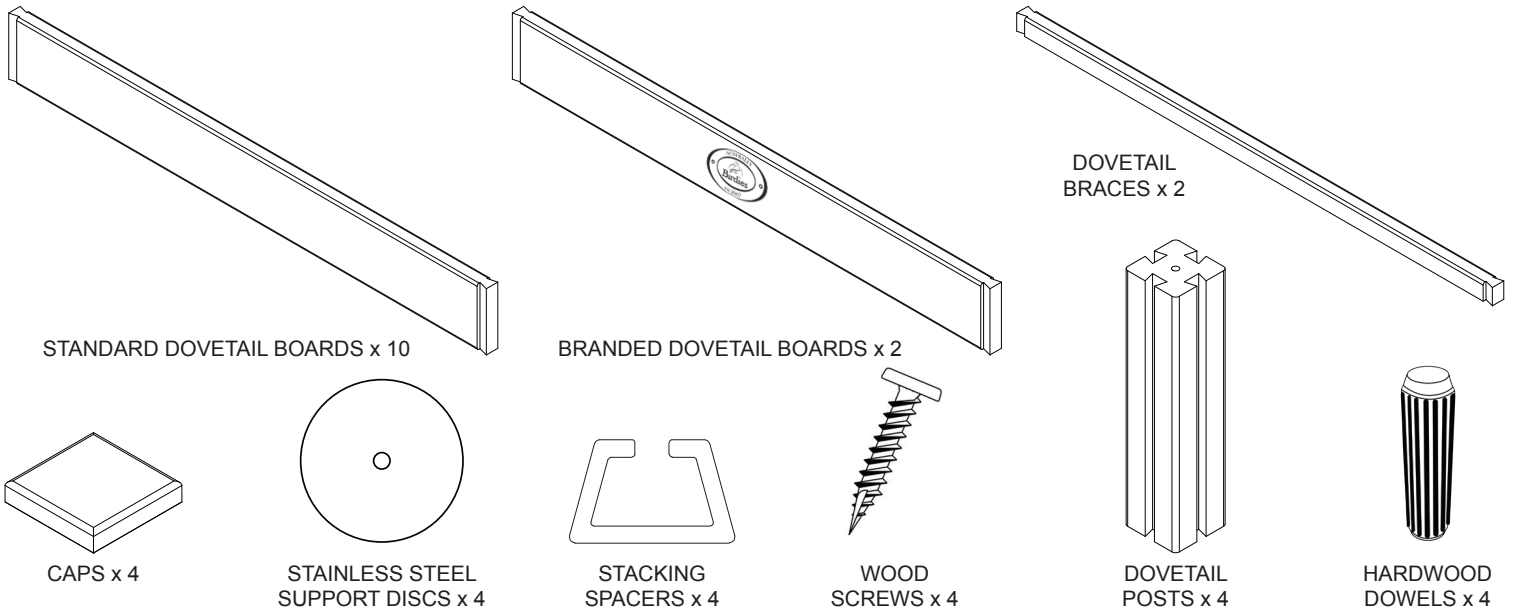

SPECIAL INSTRUCTIONS

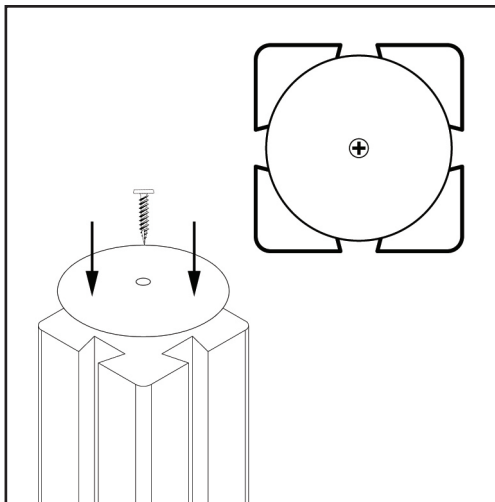

Placing the bed on level ground is advised. Screw the disc to the bottom of the post as shown. Note the larger 8mm hole is the top of the post. The disc is not required on hard level surfaces such as concrete, deck or pavers

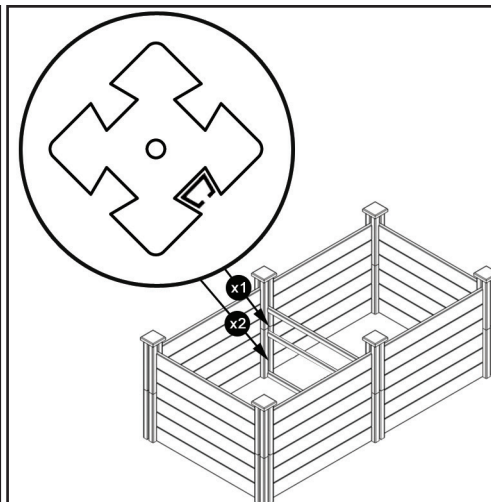

When stacking the beds we provide 107mm stacking spacers which are inserted in each post as shown in the 3 kit bed example above. Slide in first brace, then insert 2 x 107mm stacking spacers, slide in second brace resting it on the 2 spacers, insert 1 x 107mm stacking spacer and slide in final brace.

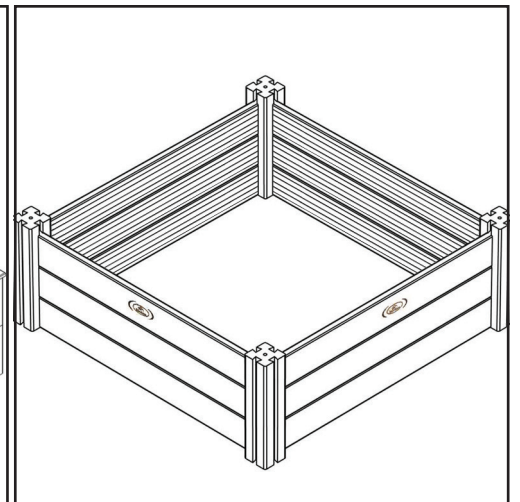

IMPORTANT
The grooved (reeded) side of the timber boards must face inwards.

SINGLE KIT ASSEMBLY

STAGE 01

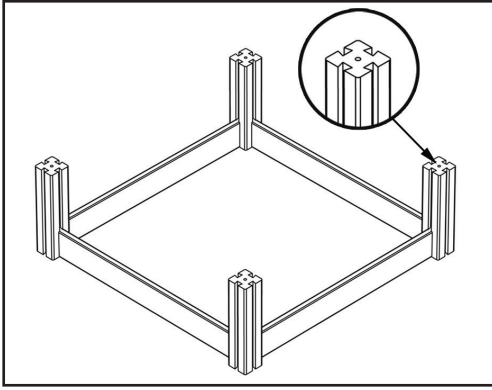

Remove posts and attach discs, ensuring the 8mm hole is on top and slide in first row of non-branded boards by holding each end of the boards and applying equal force downwards.

STAGE 02

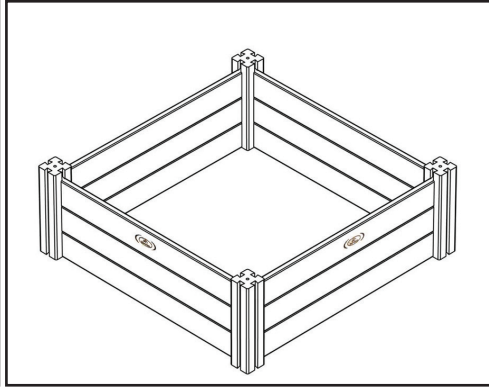

Slide in remaining 8 boards ensuring the Birdies Wood Branded board is located in the top row.

STAGE 03

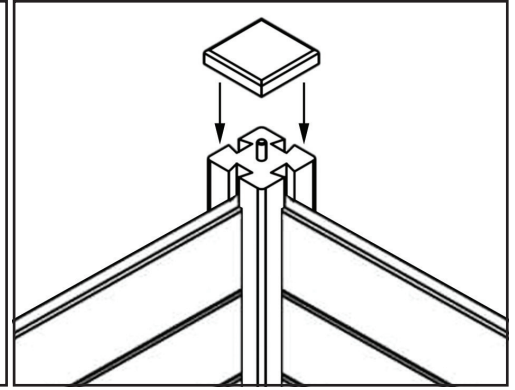

Insert the 4 hardwood dowels into the holes on the top of the posts by hand and then place 4 caps over these dowels. Push down to secure.

OPTIONAL

Wood glue can be used to fix the cap in place.

MULTI-KIT ASSEMBLY

FOR DESIGN IDEAS PLEASE REFER TO THE TOP FLAP OF THE CARTON OR VISIT WWW.BIRDIESGARDENPRODUCTS.COM.AU

STAGE 01

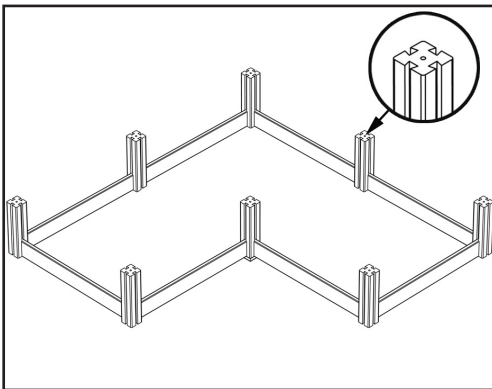

Select your required design. Remove posts & attach discs (ensuring you have the 8mm holes on top) then slide in the first row of non-branded boards by holding each end and applying equal force downwards. Slide in the remaining boards on all external sides ensuring the Birdies branded board is located in the top row.

STAGE 02

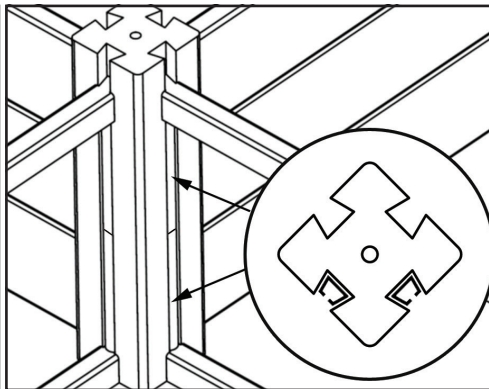

Slide in the first brace then insert 2 x 107mm stacking spacers in each post. Slide in the second brace until it rests onto the spacers.

STAGE 03

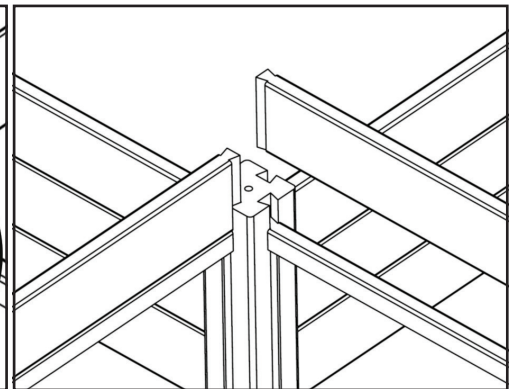

Slide in a first row of non branded boards, placing them onto the top brace.

STAGE 04

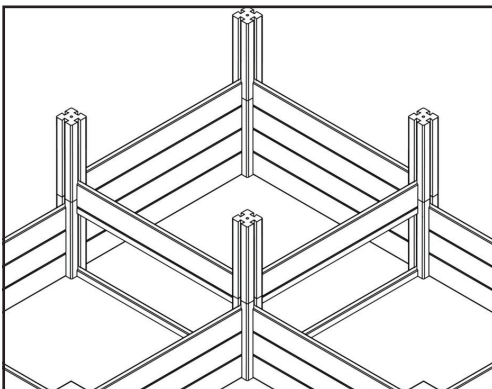

Slide in the next block of posts (ensuring the 8mm hole is positioned at the top) and then slide in the remaining boards making sure the Birdies Wood Branded board is located in the top row.

STAGE 05

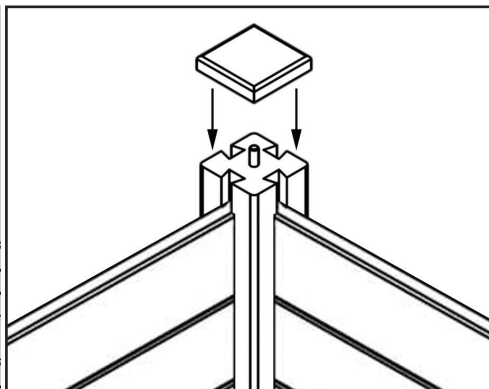

Insert the 4 hardwood dowels into the top of the posts and then place 4 caps over these dowels and push down to secure. OPTIONAL: Wood glue can be used to fix the cap in place

STAGE 06

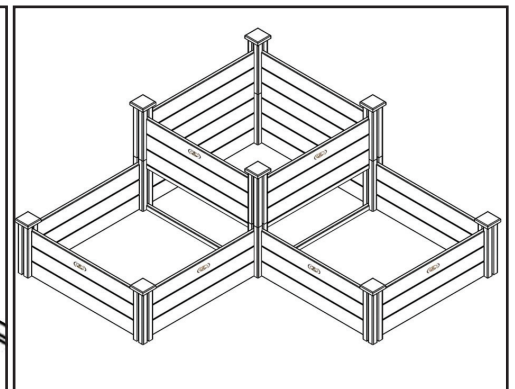

Completed bed!!