

# METAL WORKBENCH

## 925H x 1800W x 6000mm

ITEM NO: GOS020

**POWDER  
COATED  
BLACK**

**500kg  
BENCH TOP**

### SAFETY TIP:

When assembling or installing this product wear protective gloves and eyewear.

**Very Important:** Unpack the unit and confirm that you have all the parts listed. Assemble the unit on a solid, level surface. Avoid carpet. You will need the assistance of a second person during assembly. **You will need the following:** Rubber mallet, Phillips-head screwdriver and an adjustable spanner.

#### Parts list:

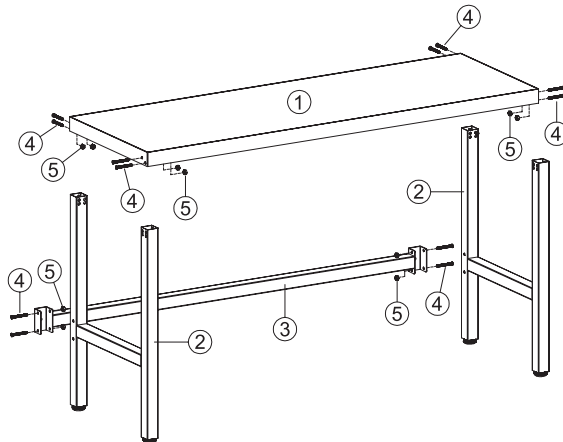

NO.	PARTS NAME	PCS
1	MDF table top	1 PC
2	H leg frame	2 PCS
3	Horizontal back brace	1 PC
4	M8 x 70mm Pan head bolt	12 PCS
5	M8 Hex nut	12 PCS

#### Step 1

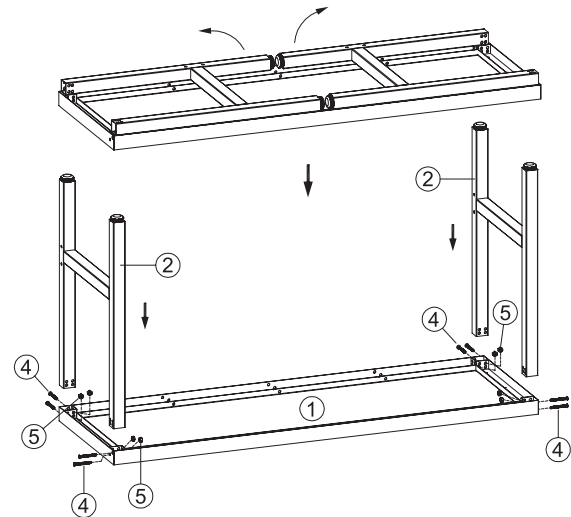

Lay the whole package on the ground with the table top (1) facing down. Lift both H leg frames (2) upright as per diagram above and insert the leg frames (2) into the slots on each side of the table top (1). Fix both H leg frames (2) to the table top (1) using the provided pan head bolts (4) and hex nuts (5).

#### Step 2

Invert the workbench so it is in an upright position. Attach the horizontal back brace (3) and fix it to the leg frames (2) using the provided pan head bolts (4) and hex nuts (5) as per diagram.

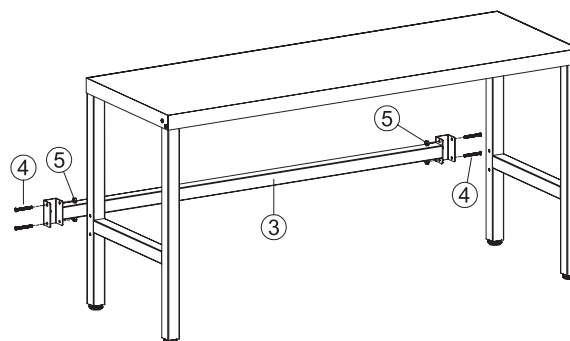

#### Step 3

Assembly is now complete and the workbench is ready to use.

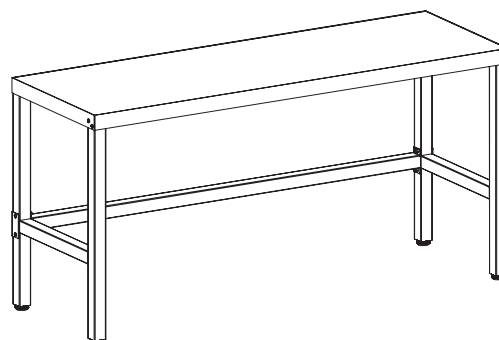

#### WARRANTY CONDITIONS

Any claim under this warranty must be made within 1 year of the date of purchase of the product. To make a claim under this warranty, take the product (with proof of purchase) to any Bunnings store (see [www.bunnings.com.au](http://www.bunnings.com.au) for store locations). Pinnacle Hardware bears reasonable, direct expenses of claiming under the warranty. You may submit details and proof of purchase to our support centre for consideration. The warranty covers manufacturer defects in materials, workmanship and finish under normal use. This warranty is provided in addition to other rights and remedies you may have under law: Our goods come with guarantees that cannot be excluded under the Australian consumer law. You are entitled to a replacement or refund for a major failure and compensation for any other reasonably foreseeable loss or damage. You are also entitled to have the goods repaired or replaced if the goods fail to be of acceptable quality and the failure does not amount to a major failure. This warranty excludes damage resulting from product misuse or product neglect. The warranty covers domestic use only and does not apply to commercial applications. This warranty is given by Pinnacle Hardware, ABN 67 614 496 196, 28 Hudson Court, Keysborough Vic 3173, 1800 349 776, Email: [support@pinnacle.net.au](mailto:support@pinnacle.net.au). New Zealand customers please contact HARCO (Harkness & Young Ltd), 09 27 64071, Email: [sales@harknessyoung.co.nz](mailto:sales@harknessyoung.co.nz). 'Pinnacle' is a trademark. © Pinnacle Hardware. Suitable for model number GOS020.