



# MULTISTORE

## ASSEMBLY INSTRUCTION FOR LSD 550

**WARNING:** Serious injury or death can be caused by toppling furniture

**Help prevent tip-over:**

- Anchor this product to a wall or other suitable surface
- Check anchors regularly
- Avoid placing TVs on top unless the TV is also anchored
- Use drawer locks to prevent children climbing



### LSD 550

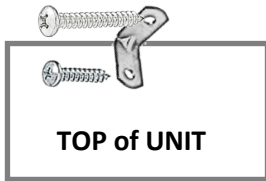

When attaching unit to wall put safety bracket in middle of unit with 16mm pan head screw then 25mm pan head screw into wall. For plaster-board without a stud it is recommended to use a plug with screw (not provided).

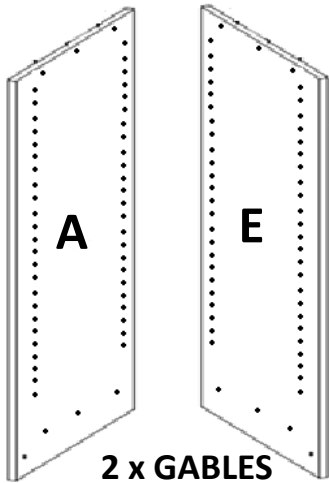

1 x BOTTOM KICK



2 x FIXED SHELVES

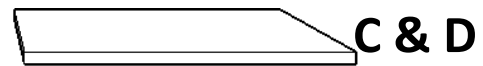

1 x FOLDED BACK

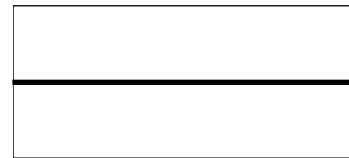

1 x INFILL



2 x HANDLES





NO	MODEL	DESCRIPTION	QTY
1		CONFIRMAT SCREWS 50mm x 5mm	10
2		WHITE CAPS	10
3		BACKING NAILS	75
4		16mm PAN HEAD WOOD SCREWS	1
5		25mm PAN HEAD WOOD SCREWS	1
6		30mm COUNTER SUNK WOOD SCREWS	3
7		"L" SAFETY BRACKET	1

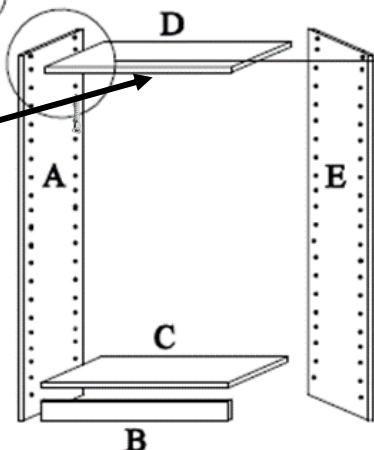
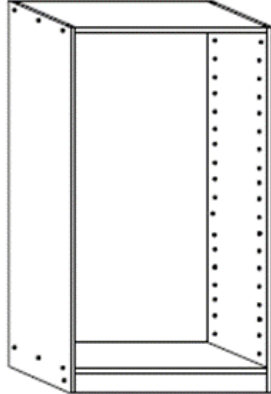
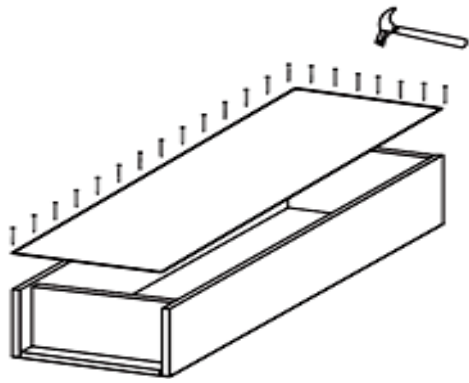

# MULTISTORE

## ASSEMBLY INSTRUCTION FOR LSD 550

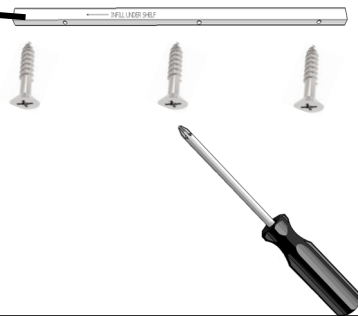
<p>①</p>  <p>A</p> <p>B</p> <p>C</p> <p>D</p> <p>E</p>	<p>②</p>  <p>USE 50mm X 5mm screws</p> <p>FIXED SHELF</p>
	
 <p><b>INFILL</b></p> <p>YOU WILL NEED TO RETRIEVE THE INFILL, USING 3 X 30mm SCREWS PROVIDED, ATTACH THE INFILL TO THE UNDER-SIDE OF THE CAM SHELF BEFORE PUTTING YOUR SHELF INTO PLACE.</p>	



## ASSEMBLY INSTRUCTION FOR LSD 550 DRAWERS

NO	MODEL	DESCRIPTION	QTY	NO	MODEL	DESCRIPTION	QTY
1		CONFIRMAT SCREWS	8	5		CAMS	4
2		DOWELS	8	6		CAM PINS	4
3		BACKING NAILS	60	7		EURO SCREW	8
4		16mm WOOD SCREWS	12	8		DRAWER RUNNERS	2

### STEP 1.

LAYOUT YOUR DRAWER PIECES FLAT AS PER DESIGN WITH PRE-DRILLED HOLES FACING UP.

START WITH THE BACK OF THE FRONT DRAWER AND PLACE YOUR DOWELS & CAM PIN IN THE PRE-DRILLED HOLES ON EITHER SIDE AS INSTRUCTED BELOW.

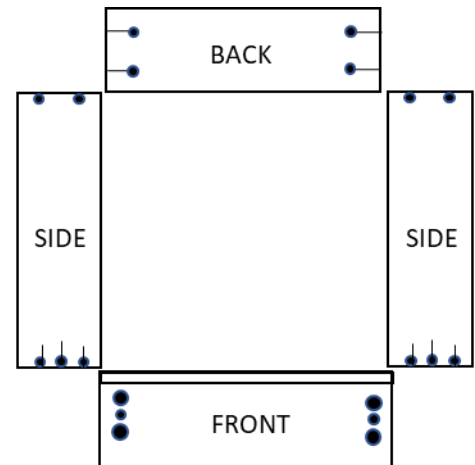
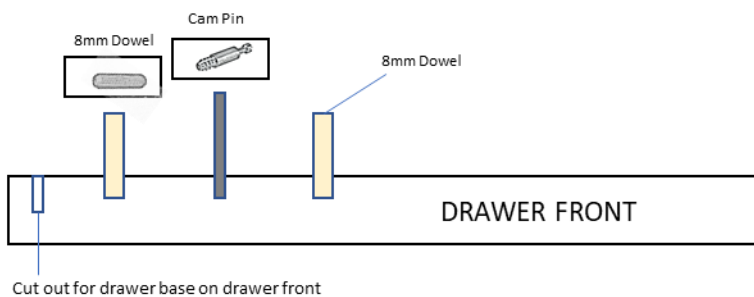

### STEP 2.

GRAB YOUR FIRST SIDE AND INSERT YOUR CAMS INTO THE HOLE PROVIDED ON THE OUTSIDE OF THE DRAWER SIDE GENTLY AS PER INSTRUCTIONS BELOW.



IMPORTANT NOTICE:

PLACE THE FITTING OVER THE HOLE KEEPING THE SQUARE EDGE OF THE FITTING PARALLEL TO THE FACE OF THE BOARD, KNOCK IN **CAREFULLY**.

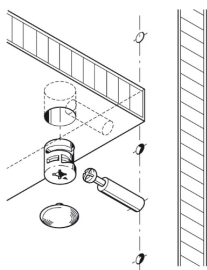

**PUSH THE SIDE INTO THE FRONT DOWELS & PIN AND THEN CAREFULLY USING A SCREW DRIVER TURN UNTIL IT LOCKS IN. REPEAT THIS PROCESS WITH THE OTHER SIDE.**

**NOW PLACE YOUR LAST PIECE BETWEEN THE TWO SIDES USING THE SCREWS: NO: 1 SUPPLIED SCREW INTO THE SIDES OF THE BACK DRAWER PIECE.**



# MULTISTORE

## ***DRAWER ASSEMBLY***

### **STEP 3.**

YOUR DRAWER SHOULD BE FACING DOWN WITH THE FRONT DRAWER EXPOSING THE CUTOUT FOR THE BASE TO BE PUSHED INTO FACE DOWN WITH THE BROWN SIDE SHOWING. MAKING SURE YOU HAVE THE DRAWER SQUARE, PROCEED TO NAIL DOWN THE BASE SPACING THEM OUT AROUND THE EDGE OF THE THREE SIDES.

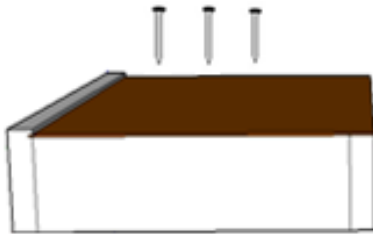

### **STEP 4.**

#### **RUNNER PLACEMENT**

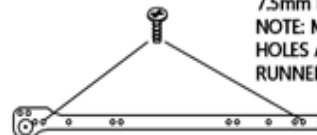

7.5mm EURO SCREW  
NOTE: MAKE SURE CORRECT HOLES ARE USED FOR RUNNER PLACEMENT.

C-LEFT-GABLE RUNNER

PLACE YOUR RUNNERS INTO THE DESIGNATED HOLES MAKING SURE THE WHEEL IS FACING TO THE FRONT ON THE GABLE.

HOLE POSITION NO 1 AND 8.

YOUR DRAWER RUNNER WILL HAVE THE WHEEL TO THE BACK OF THE DRAWER.

### **STEP 5.**

USING THE HANDLE SCREW (NO:4) ATTACHED THE HANDLE TO THE BACK OF THE DRAWER FRONT INTO THE PREDRILLED HOLES ALREADY PROVIDED.

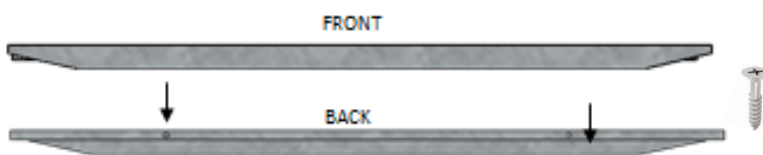

### **STEP 6.**

PLACE YOUR DRAWER RUNNER ON THE BOTTOM OF THE DRAWER FLUSH WITH BACK OF DRAWER, THEN USING THE WOOD SCREWS PROVIDED (No:4) SCREW TWO INTO EACH RUNNER . REPEAT FOR THE OTHER SIDE.

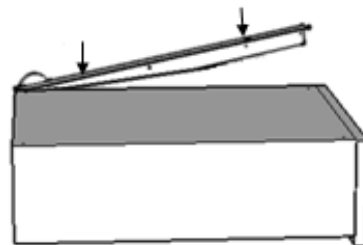

### **PICTURE OF YOUR FINISHED DRAWER**



Multistore Industries (Aust) Pty Ltd

9 Nevilles Street, Underwood, QLD 4119

Tel—(07) 3208 6799

Fax- (07) 3209 6332

[www.multistore.com.au](http://www.multistore.com.au)

[sales@multistore.com.au](mailto:sales@multistore.com.au)



---

## **WARRANTY**

---

Our goods come with guarantees that cannot be excluded under the Australian Consumer Law. You are entitled to a replacement or refund for major failure.

### 10 Year Warranty

- If the purchaser has a fault or defect with this product, the purchaser needs to contact Multistore Industries (Aust) directly on (07) 3208 6799 and state date of purchase, place of purchase and proof of purchase.
- Multistore Industries (Aust) will replace any faulty or defect parts at no cost to the customer. A replacement will be sent to you as soon as possible, or product can be exchanged at the store of purchase.
- This warranty is in addition to other rights and remedies of the customer under law.

Sincerely,

Multistore Industries (Aust) Management