

# TOPDRY Rotary Ground Socket

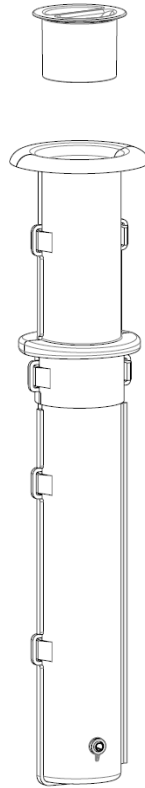

## 1. Choose a location and Install the Ground Socket

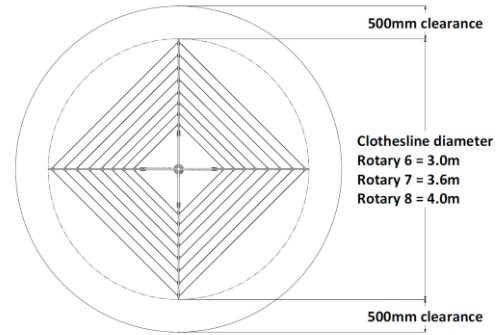
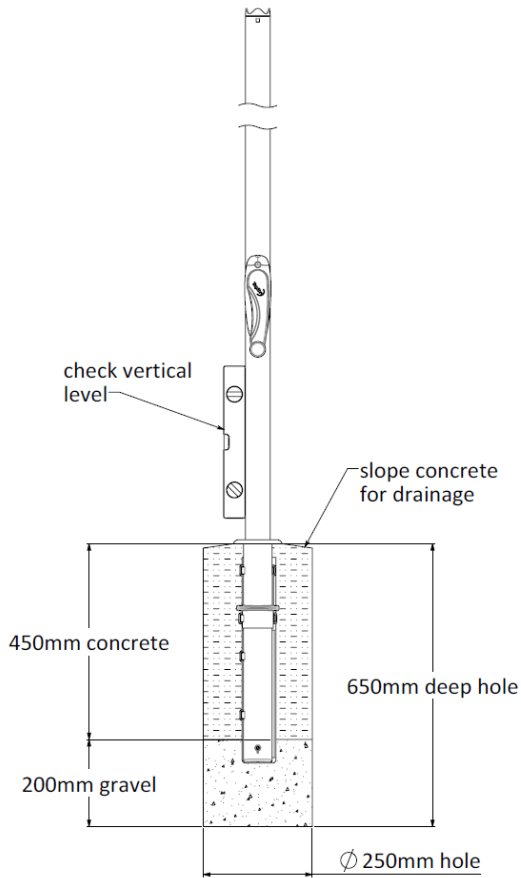

1. Choose a suitable location.
2. Dig a hole in the centre of the space 650mm deep and 250mm in diameter.
3. Fill the bottom of the hole with 200mm of dry gravel.
4. Fit the ground socket to the end of the main post. Rotate the post in the ground socket until it locks.
5. Position the Ground Socket and Main Post in the centre of the hole.
6. Ensure the top of the Ground Socket is 5mm above the surface of the concrete.
7. Fill the hole with concrete and use a spirit level to ensure the post and Ground Socket remain vertically level.
8. Smooth the concrete with a trowel
9. Slope the surface of the concrete away from the Ground Socket to aid drainage.
10. Allow the concrete to set for 48 hours before use.
11. Do not remove the Post until the concrete has set.

## 2. Removing the Clothesline from the Ground Socket

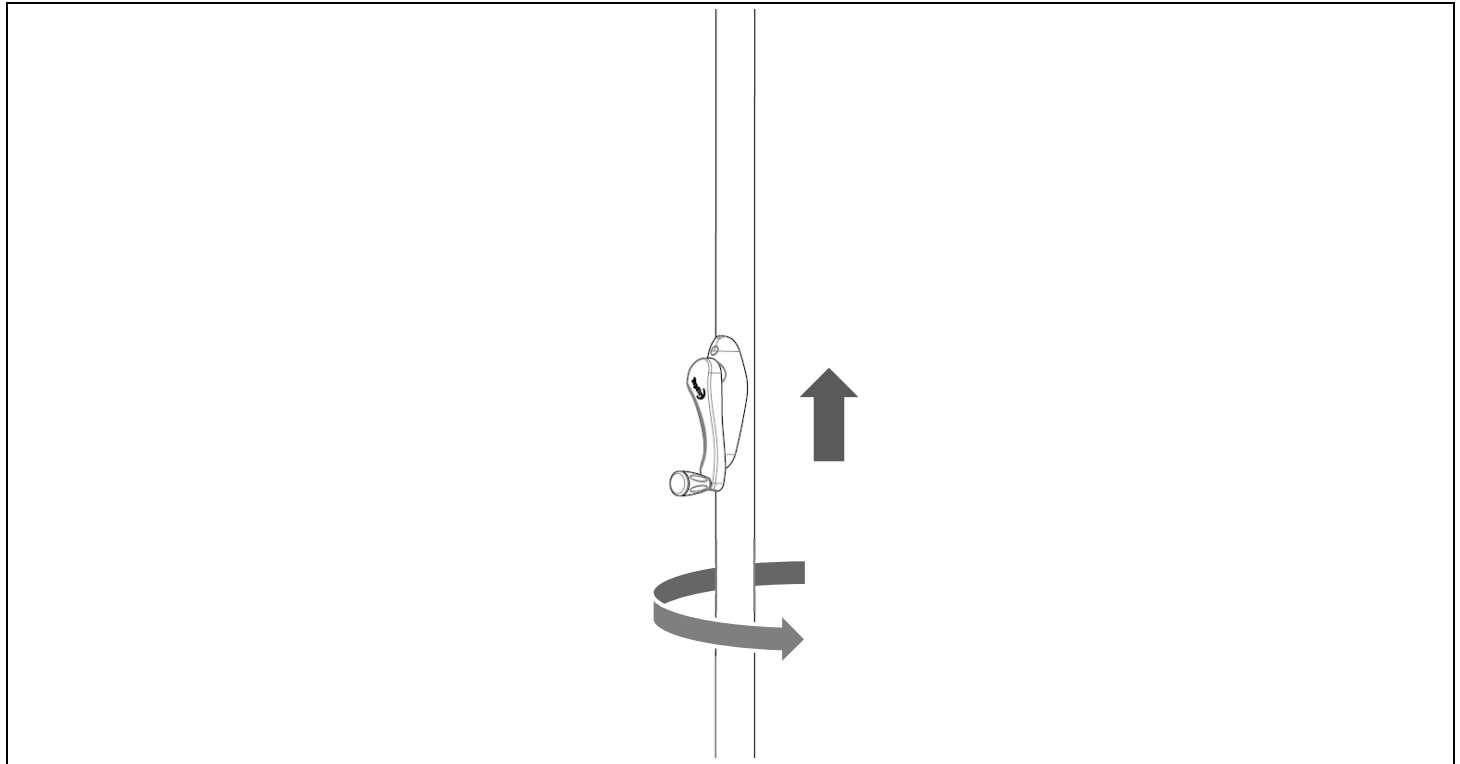

Your clothesline can be removed from the ground socket for storage. The Main tube locks to the ground socket for safety

- To remove lift while rotating anti clockwise.
- To replace lower into ground socket and rotate clockwise until it drops into place.

**Fit the cap to the ground socket when the clothesline is removed to prevent objects falling in.**

**Care and Maintenance**

Over time it is possible that soil will enter the ground socket making it difficult to remove your clothesline. To ensure your clothesline does not become stuck we recommend removing it twice a year

## **Warranty - Terms and Conditions**

Any claim under this warranty must be made within one year of the date of purchase of the product.

To make a claim under the warranty, take the product (with proof of purchase) to any Bunnings store (see [www.bunnings.com.au](http://www.bunnings.com.au) for store locations).

Sales Force National Pty Ltd (t/a Zenexus) bears reasonable, direct, expenses of claiming under the warranty. You may submit details and proof into any Bunnings store for consideration.

The warranty covers manufacturer defects in materials, workmanship and finish under normal use.

This warranty is provided in addition to other rights and remedies you may have under law: our goods come with guarantees which cannot be excluded under the Australian Consumer Law. You are entitled to replacement or refund for a major failure and to compensation for other reasonably foreseeable loss or damage. You are also entitled to have the goods repaired or replaced if the goods fail to be of acceptable quality and the failure does not amount to a major failure. If the clothesline is repaired or partly replaced under warranty the original warranty will not be extended

The warranty excludes damage resulting from product misuse or product neglect. The warranty covers domestic use only and does not apply to commercial applications.

This warranty is given by Sales Force National Pty Ltd (t/a Zenexus), ABN: 60 110 379 587. Phone: 1300 734 714 (AU), 0800 800 040 (NZ). E-mail: [customerservice@zenexus.com.au](mailto:customerservice@zenexus.com.au), [customerservice@zenexus.co.nz](mailto:customerservice@zenexus.co.nz). Website: [www.zenexus.com.au](http://www.zenexus.com.au)

## **WARRANTY EXCLUSIONS**

Fading due to weather exposure or damage to the frame and line through accident misuse or negligence.