

BLANCO

Instructions for the Use and Care and Installation of

BCC604T

Touch Control Cooktop

BLANCO

Thank you for your choosing Blanco. You will find that the clean lines and modern look of your Blanco appliance blends perfectly with your kitchen décor. It is easy to use and performs to a high standard. Blanco is committed to providing increasingly efficient products that are attractive, reliable, easy to use and respect the environment.

Of course we make every effort to ensure that our products meet all your requirements, and our Customer Relations department is at your disposal, to answer your questions and to listen to all your suggestions (see back cover of manual).

For important information such as instruction manuals and catalogues, please visit our website blanco-australia.com/support/instruction_manuals or blanco-australia.com/support/catalogues.

Please make sure you activate your product warranty by registering your warranty online at blanco-australia.com/warranty/ and retain all documents relating to the purchase of this product.

We value your opinion, so please let us know your thoughts about your new appliance. Simply go to the relevant appliance page of our website blanco-australia.com and click on "Write a Review".

If you want to know more about promotions, receive tips and tailor made content or connect with us on social media, like [BlancoAU](#) on Facebook and follow [BlancoAU](#) on Twitter.

We hope you'll enjoy special moments with your new appliance and remember, we're only one click away!



blanco-australia.com



BlancoAU



BlancoAU

Dear Customer

You will find that the clean lines and modern look of your Blanco cooktop blends in perfectly with your kitchen décor. It is easy to use and performs to a high standard.

Blanco also makes a range of products that will enhance your kitchen – such as ovens, rangehoods, dishwashers, microwaves, sinks and taps. There are models to complement your new Blanco cooktop. Blanco now has a range of laundry products to choose from.

Of course, we make every effort to ensure that our products meet all your requirements, and our Customer Relations Department is at your disposal, to answer all your questions and to listen to all your suggestions.

Please complete the warranty section of this manual and keep your receipt as proof of purchase. Retain all documents relating to the purchase of Blanco product.

Blanco is committed to providing increasingly efficient products that are easy to use, respect the environment and are attractive and reliable.

BLANCO

CONTENTS

SECTION PAGE NO.

Safety Warnings 2-3

Description 4-5

Use 8-9

Cooking Guide 10

Cleaning 11

Installation 12-16

Servicing 17

Trouble Shooting 18-19

Technical Data 20

Warranty Card

SAFETY WARNINGS

The appliance is not intended for use by persons (including children) with reduced physical, sensory or mental capabilities, or lack of experience and knowledge, unless they have been given supervised or instruction concerning use the appliance by a responsible person for their safety.

Young children should be supervised to ensure that do not play with the appliance.

If the supply cord is damaged, it must be replaced by the manufacturer or its service agent or a similarly qualified person in order to avoid a hazard.

Do not use a steam cleaner to clean this appliance.

WARNING: If the surface is cracked, switch off the appliance to avoid the possibility of an electric shock.

This appliance is not intended to be operated by means of external timer or separate remote control system.

If the electrical supply is restricted, means of all-pole disconnection mus be accessible and incorporated in the fixed wiring in accordance with the wiring rules.

Danger of fire - Do not store items on the cooking surface.

CAUTION - The cooking process has to be supervised. A short term cooking process has to be supervised continuously.

WARNING - Unattended cooking on a hob with fat of oil can be dangerous and may result in a fire. Never try to extinguish a fire with water, but switch off the appliance and then cover the fire with a lid or fire blanket.

Do not modify this appliance.

Do not use as a room heater.

This appliance is meant for indoor use only.

Failure to follow these usage, installation and maintenance instructions could result in a safety hazard resulting in injury or death.

SAFETY WARNINGS

WARNING FOR USE:

- ▶ **The appliance is built to perform the following function, cooking and heating food. Every other use is considered improper.**
- ▶ **Never use this appliance as a room heater.**
- ▶ **Do not attempt to change the technical characteristics of the product as it can be dangerous and can affect your product.**
- ▶ **For disposal of this product, ensure it is done in a safe manour and following all local recycling guidelines.**
- ▶ **Do not touch the appliance with wet or damp hands or feet.**
- ▶ **Do not use the appliance barefoot.**
- ▶ **The manufacturer will not be liable for any damage resulting from improper, incorrect or unreasonable use.**
- ▶ **During, and immediately after operation, some parts of the cook top are very hot: avoid touching them.**
- ▶ **Do Not leave heating elements on when not in use.**
- ▶ **If the ceramic glass hob is not cleaned immediately, there is a risk of residues becoming encrusted that they will be impossible to remove after the hob has cooled.**
- ▶ **Before cooking for the first time, it is necessary to clean the hob as follows: switch on the front heating elements to the maximum for at least 30 minutes, heating pans full of water.**

After 30 minutes, switch off the front heating elements and switch on the rear heating elements plus the central heating element, where possible, to the maximum. This is necessary to eliminate the “new smell” and to allow any humidity which may have formed during the production process to evaporate. This is necessary for the correct operation of the electronic circuits and the control panel. If the controls do not work properly when the 30 minutes are up, there is still some humidity inside, leave the heating elements on until all the humidity has completely evaporated, then switch off the hob.

Connection to the mains

When cook-top will be connected to power supply, a long beep will be hear. All leds and displays in the Touch Control will be turned ON during 4 seconds. After an auto adjust period, cook-top go into standby mode.

DESCRIPTION

The appliance has 4 cooking zones of different sizes and power levels. The heating elements are of the Hi-light type, which come on after a few seconds, and the heat is adjusted using the buttons on the touch control panel, from a minimum of 1 to a maximum of 9.

The cooking zones with concentric or oval disks have a double heating system: in the area inside the small diameter or over both diameters.

1. 180mm Cooking Zone. 1800 W
2. 140mm Cooking Zone. 1200 W
3. Touch Control Panel

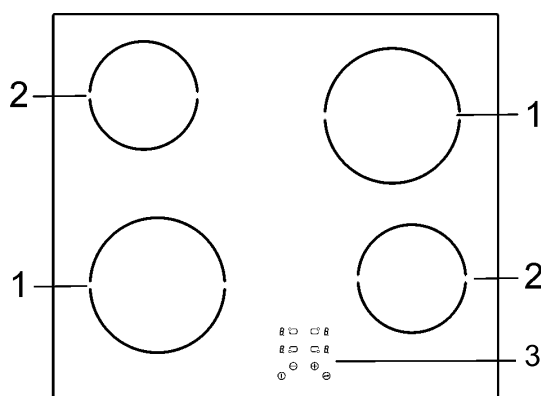

CAUTION:

In case of hotplate glass breakage:

- ***shut immediately off all burners and any electrical heating element and isolate the appliance from the power supply;***
- ***do not touch the appliance surface;***
- ***do not use the appliance.***

DESCRIPTION

Model BCC604T

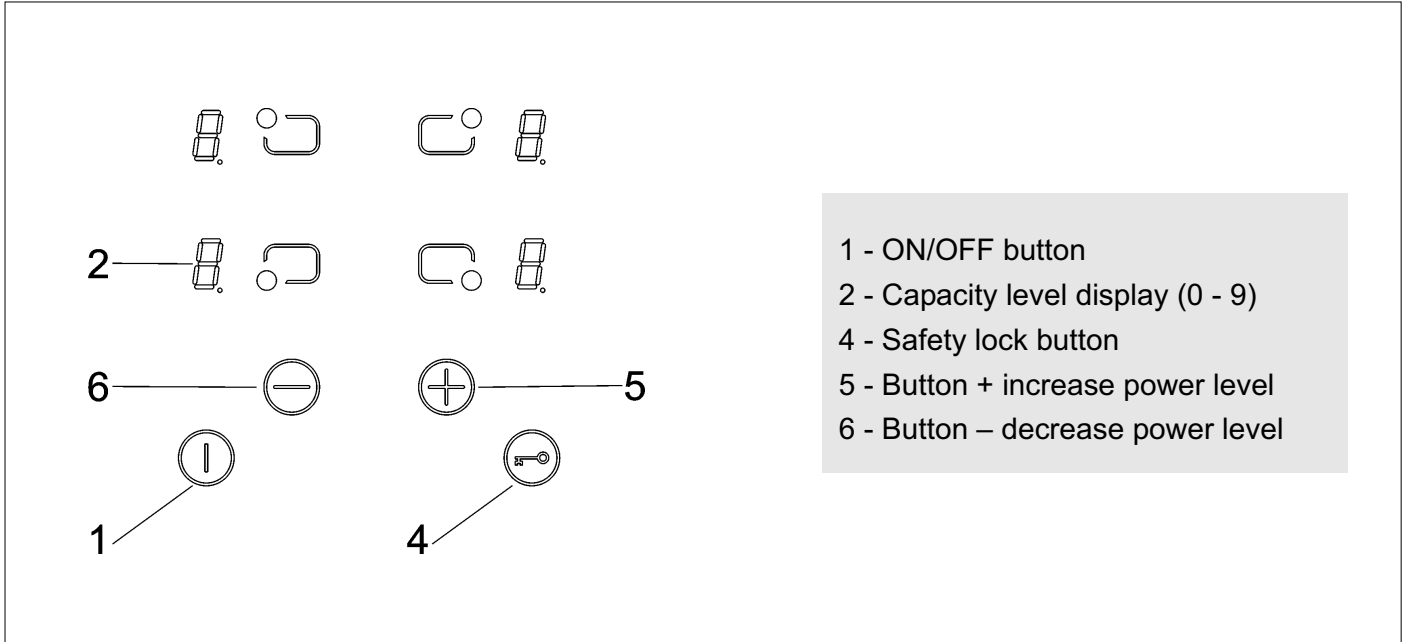

- 1 - ON/OFF button
- 2 - Capacity level display (0 - 9)
- 4 - Safety lock button
- 5 - Button + increase power level
- 6 - Button - decrease power level

DESCRIPTION

ARRANGEMENT OF THE HEATING ELEMENTS

Model BCC604T

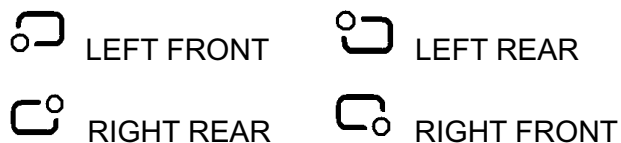

SWITCH ON/OFF A HEATER ZONE

To switch ON a heater Touch any heater's zone during 400 msec. Long beep will be heard and "0" value will appear in target zone digit, indicating power level.

- If any cooking stage is in position **0**, this display will switch OFF automatically after 10 seconds and the zone OFF sequence will sound.
- If there is residual heat indication in the display which is ON but in **0** power, "**0**" will appear changing over.
- If lock function is active you cannot switch ON a zone.

To switch OFF a heater Touch any heater's zone during 1, 2 sec. 3 short beeps will be heard and nothing or "H" value will appear in target zone digit if residual heat exists. Zone will be OFF.

- If any cooking stage is in position **0**, this display will switch OFF automatically after 10 seconds and the zone OFF sequence will sound.
- If there is residual heat indication in the display which is OFF, "**H**" will be displayed.
- Even lock function is active you can switch OFF a zone.
- If only one heater is active and this one is switched off, 4 short beep will be heard indicating all cook top is OFF.

INCREASE/DECREASE POWER LEVEL

With a short press on '+' or '-' keys, increase or decrease power in the selected zones digit: 0 - 1 - 2 - 3... 9 - P.

- Direct Access to **P** from **0** level pressing **-** key.
- For long presses in **+** or **-** keys, power level increases/decreases continuously. With a fast increase, power stops at level 9, and for a higher power another short press is needed on the **+** key. No beep sound is heard with fast increase/decrease.
- Once arrived to **P** power level, pressing **+** key again does not change power level to **0**.
- With a zone ON at **0** power level, if the zone is hot, **0** will blink alternatively. After 10 seconds, **0** will disappear an '**H**' letter will appear fixed on display.
- When a heater is selected and **+** and **-** keys are touched at the same time, power level will go to '**0**' but heater will maintain selected during 10 seconds.

DESCRIPTION

CHILD LOCK OPTION

When there isn't a specific key to develop this function, press combination of FL and RL zones selection keys for 2 sec. Short beep will be heard and displays will show "L" letter during 2 sec.

Then, any time when a key will be touched, displays will show "L" during 2 sec. heating remains at the same state.

To deactivate Child Lock, follow the same process explained before. Then short beep will be heard and displays will show "n" letter. Hob will remain unlocked.

*Note: **An automatic child lock** will produce in 15 minutes after total switch OFF of the hob. This function will happens automatically but previously is necessary to programme it. See User settings point.*

Automatic Child Lock

Press key sequence: + and – combined and 1 long beep and 1 short beep will be heard. Before 2 sec passed, touch + key.

When symbol  appears, it means that automatic child lock is active.

Touching – key, automatic child lock deactivate. Settings validation will produce after a 5 sec. timeout .

When any of these two option is selected, display will show the option active in this moment.

DOUBLE ZONES

To switch ON double extension ring, associated main zone must be already ON and

Indicating power level must be higher than 0.

1st short press on extension key  switches ON extension ring.

LED over extension key turns ON if extension ring is ON.

2nd Short Press on extension key  switches OFF extension ring.

Short beep each press on extension key .

USE

OVERFLOW

Something (an object or a liquid) is pressing any key during more than 5s. 2 short beep + 1 long beep every 30s while the key is pressed. Cook-top will turn OFF.



This symbol will maintain blinking while the matter persist.

AUTOMATIC SAFETY OFF

If the power level is not changed during a preset time, the corresponding heater turns off automatically.

The maximum time a heater can stay on, depends on the selected cooking level.

Power level	Max. time on (hours)
1	10
2	5
3	5
4	4
5	3
6	2
7	2
8	2
9	1
P	1

CAUTION:

In case of hotplate glass breakage:

- shut immediately off all burners and any electrical heating element and isolate the appliance from the power supply;***
- do not touch the appliance surface;***
- do not use the appliance.***

USE

WARNINGS:

for a correct use, please look at fig. 1 and remind:

- *switch on the electricity only after having placed the pot on the cooking zone.*
- *Use pots and pans with flat solid bottoms.*
- *Use pots with the same diameter of the cooking zones.*
- *Dry the bottom of the pot before put in on the cooking zones.*
- *Do not scrape the pot against the glass so to not damage it.*
- *During the use of the cooking zones, please, keep the children away from the hot plates. Pay close attention to children, because they are unlikely to see the letter "H" indicating that the plates are still hot. After using the hob, the heating areas remain very hot for some time, even after being switched off. Do not allow children to place their hands on the hob. After using the hob, always check that the controls are in the "0" (off) position.*

Make sure that the handles of the pots are placed in the right way towards the interior. Be aware that overheated fats and oils may become inflamed.

- *Cooking zones after using remain warm; don't leave objects, don't lean your hands so to avoid burns, till the indicator light is off.*
- *If the glass cracks, please, disconnect the appliance.*
- *Don't use plastic pots or aluminium sheets.*
- *Don't use hob as a supplementary surface.*

In order to cook with the cooking zone efficiently using the least amount of energy, use: thick, flat-bottomed pots of a width suited to that of the cooking zone (see picture). Cook with the lid on to also save energy. Turn down the heating element when it reaches boiling point.

Note:

In order to avoid any undesired disturbance on the touch control, place correct pots inside the marked place of the glass ceramic surface (see fig. 1).

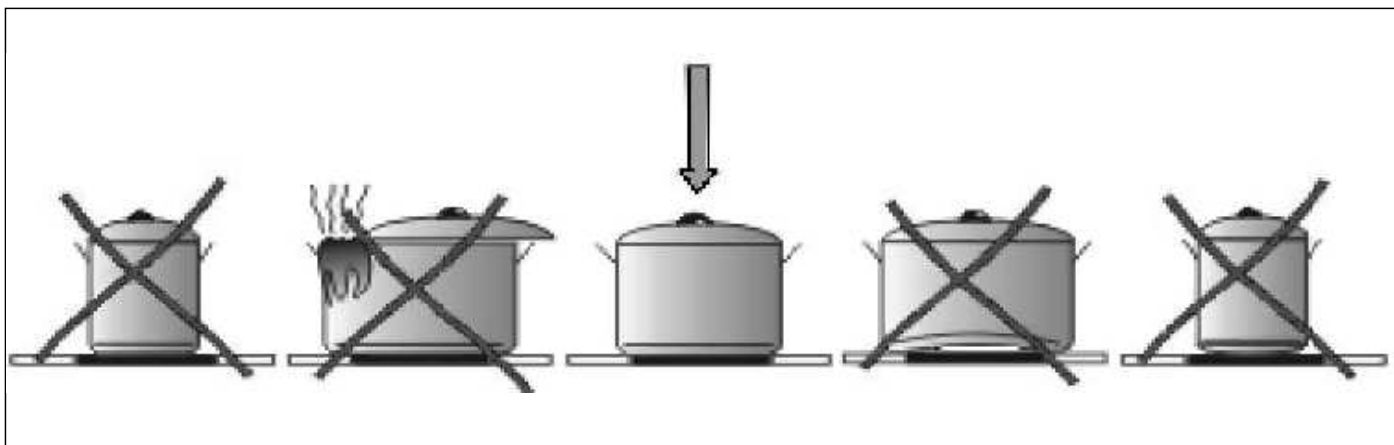

FIG. 1

COOKING GUIDE

The table below indicates the power values that can be set and the type of food to prepare is shown next to each one. The values can change according to the amount of food and consumer preference.

TABLE

Touch control positions	Cooking operations
1	To melt butter, chocolate and else.
1 - 3	To heat small amounts of liquid and to keep dishes warm.
4 - 8	To heat larger amounts of liquid; to prepare creams and sauces requiring lengthy cooking times.
5 - 9	To cook foods that have to be boiled, for delicate roastmeats and fish.
9 - P	To boil large amounts of liquid, to fry.

CLEANING

Before any cleaning operation, disconnect the appliance from the electric circuit.

If you want to preserve the surface clean and bright, we recommend you to use a silicone conditioner. The use of this conditioners, prior to jam-making, helps to protect the surface of the hob. This protective film is not durable, so it is advisable to repeat the application of the product frequently.

It is very important to clean the surface soon after every use, when the glass is still tepid.

Do not use metallic sponges, powder abrasives or corrosive sprays.

Depending on the dirty level we recommend:

- slight stains: it is enough the use of a moist clean rag.
- Burnt or soiling may be removed with a special razor scraper (fig. 2); **be aware that the razor can cause wounds.**

- Marks of liquid, overflowed from the pot, can be removed using vinegar or lemon.

- **Pay attention to not let fall sugar or element with sugar. In this case turn the switch off and clean the surface with hot water and the razor blade scraper.**

- After a period of time may appear metal reflex and scratches (fig. 3) due to the wrong cleaning and the wrong use of the pots. The scratches are difficultly removable, but they do not compromise the good working of the hob.

- **Don't use steam jets for the equipment cleaning.**

CAUTION:

**do not place the glass directly on the unit.
The bottom of the hob must rest on the unit.**



FIG. 2

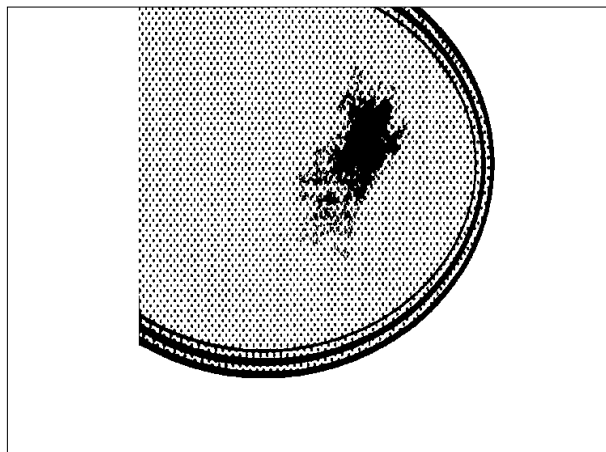

FIG. 3

INSTALLATION

TECHNICAL INSTRUCTIONS FOR THE INSTALLER

IMPORTANT: a perfect installation, adjustment or transformation of the cook top to use other gases requires a **QUALIFIED INSTALLER**: a failure to follow this rule will void the warranty.

Installation, transformations and maintenances below listed, may only be carried out by a competent technician.

The appliance must be correctly installed in conformity with current law and the manufacturer's instructions.

A wrong installation may provoke damages to persons, animals or things, for which the builder can not be responsible.

Throughout the life of the system, the devices for the safety and automatic regulation of the appliances must only be modified by the manufacturer or the duly authorised supplier.

After having cleared out all the packing components, make sure of the integrity of the appliance.

If you are in any doubt, do not use the appliance and contact qualified personnel.

The packing elements (cardboard, bags, polystyrene, nails...) must not be left within the reach of children as they are potential sources of danger.

Make a cutout in the worktop, according to the dimensions indicated in fig. 4; make sure that will be respected the critical dimensions of the space in which the appliance has to be installed (fig. 5).

In order to avoid accidental contact with the surface of the box of the overheated hob during use, it is necessary to install a wooden divider at a minimum distance of 120 mm from the top, fastening it in place with screws (fig. 4).

COMPLY WITH THE DIMENSIONS (in mm)

	A	B	C	D	E	F
(60)	560	490	55	55	60 min.	min. 120 mm

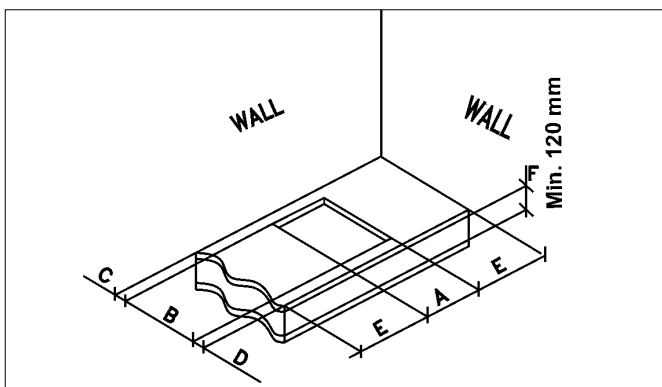

FIG. 4

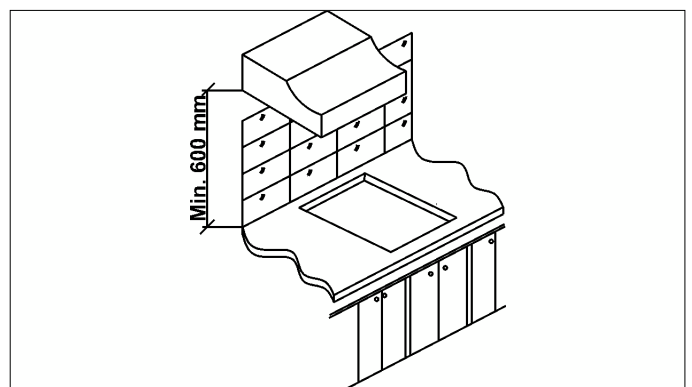

FIG. 5

INSTALLATION

A special sealing strip underneath the hob for damage. Make sure it is correctly positioned with no gaps; it avoids any water infiltration. To fix in the right way the strip, please, respect the following instructions:

- remove all the mobile parts of the hob.
- Cut the seal into 4 strips of the lengths suitable to fit it along the 4 sides of the glass.
- Overturn the hot plate and correctly position seal "E" (fig. 6) under the edge of the hot plate itself, so that the outer side of the seal perfectly matches the outer perimetral edge of the crystal. The ends of the strips must fit together without overlapping.
- Position the hob in the hole in the unit and fasten it in place using the appropriate screws "F" of the fastening hooks "G" (see fig. 7 and 7/A).

- In order to avoid accidental contact with the surface of the box of the overheated hob during use, it is necessary to install a wooden divider at a minimum distance of 120 mm from the top, fastening it in place with screws (fig. 4).
- To fasten this product to the supporting structure, we advise you not to use mechanical or electrical screwdrivers and to exercise moderate pressure by hand on the fastening hooks.

WARNINGS:

be aware that the glue that join the laminated plastic to the furniture, has to resist to temperature not below 150 °C, to avoid the unstuck of the panelling.

The rear wall, adjacent and surrounding surfaces must therefore be able to withstand an temperature of 90 °C.

MAINTENANCE SCHEDULE

Clean the cooktop surface after every use as specified within this manual.

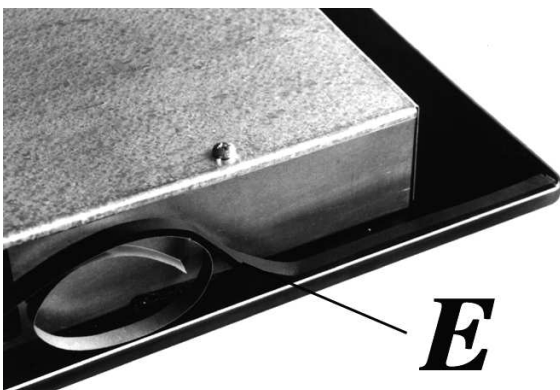

FIG. 6

INSTALLATION

POSITION HOOKS ON THE BOTTOM

Model BCC604T

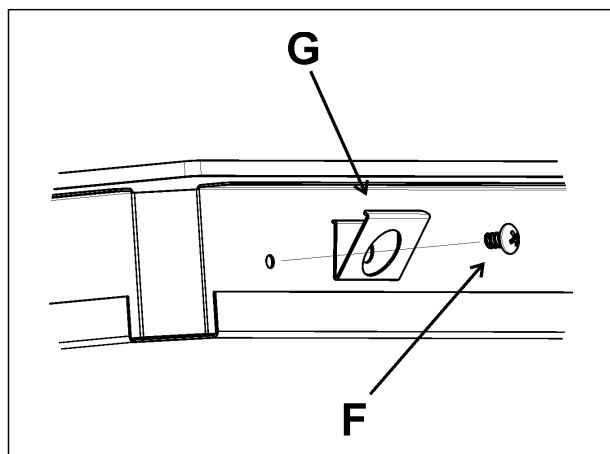

FIG. 7

POSITION HOOKS ON THE BOTTOM

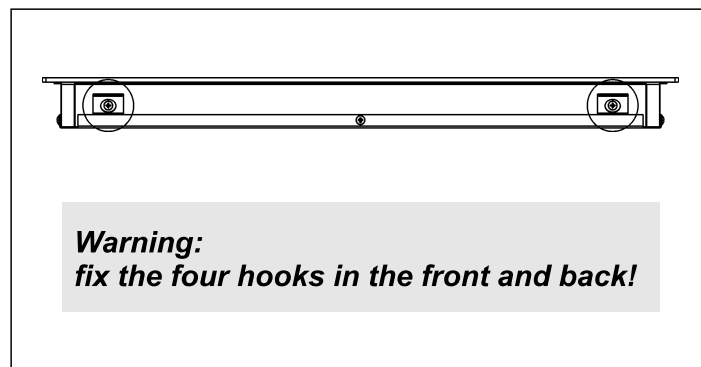

FIG. 7/A

INSTALLATION

IMPORTANT: the appliance must be installed following the manufacturer's instructions. The manufacturer will not be liable for injury to persons or animals or property damage caused by an incorrect installation.

The electrical connection has to be done in accordance with all electrical and installation requirements of the regulation.

Before proceeding with the connection, please, verify that:

- the voltage matches the value shown on the specification plate and the section of the wires of the electrical system can support the load, which is also indicated on the specification plate.
- the power of the electrical system and the power of the outlets is adequate to the maximum power of the appliance (see the identification label in the lower part of the body).
- The outlets and all the electrical system has an efficient connection to the "earth" according with the Regulation. We disclaim all responsibilities for not observing such points.

When the connection to the input system has been done through a outlet:

- apply to the input cable "C", if unprovided, a normalized plug adequate to the load indicated in the identification label. Connect the cables according to the scheme of fig. 8 - 9 - 10, making sure to respect the undermentioned correspondences:

Letter L (Live) = cable brown colour;

Letter N (Neutral) = cable blue colour;

Symbol  (Earth) = cable green - yellow colour.

- The input cable has to be located so that never reach the over temperature of 90 °C.
- Please do not use in the connection any reduction, adaptation that may provoke a false contact with following dangerous overheatings.
- The outlet must be accessible after the built-in.

When the connection has been done directly to the input system:

- interpose between the appliance and the system an onnipolar switch, in compliance with current installation regulations, with a minimum aperture between contacts of 3 mm.
- Keep in mind that the "earth" cable does not have to be interrupted by the switch.
- The electrical connection can also be protected by a differential switch with high sensitivity.

We recommend to fix the earth coloured cable to an appropriate earth installation.

Before performing any service on the electrical part of the appliance, it must absolutely be disconnected from the electrical network.

If the installation requires modifications to the home's electrical system or if the socket is incompatible with the appliance's plug, have changes or replacements performed by professionally-qualified person. In particular, this person must also make sure that the section of the wires of the socket is suitable for the power absorbed by the appliance.

WARNINGS:

all our products are conform with the European Norms and relative amendments. The product is therefore conform with the requirements of the European Directives in force relating to:

- **compatibility electromagnetic (EMC);**
- **electrical security (LVD);**
- **restriction of use of certain hazardous substances (RoHS);**
- **EcoDesign (ERP).**

INSTALLATION

Model BCC604T

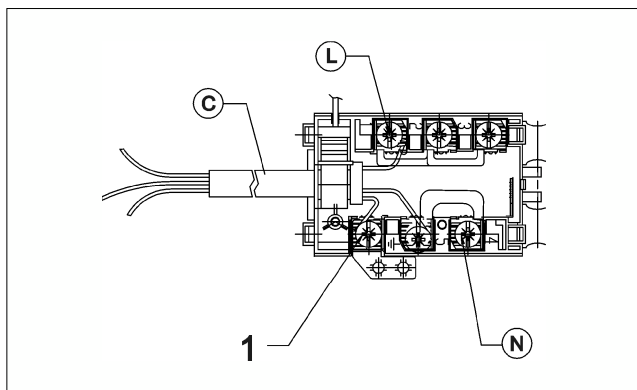

FIG. 8

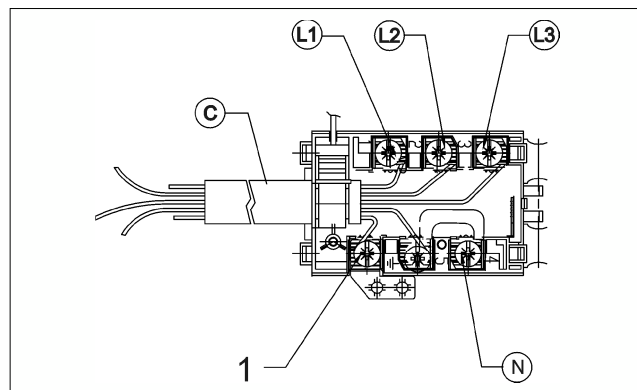

FIG. 9

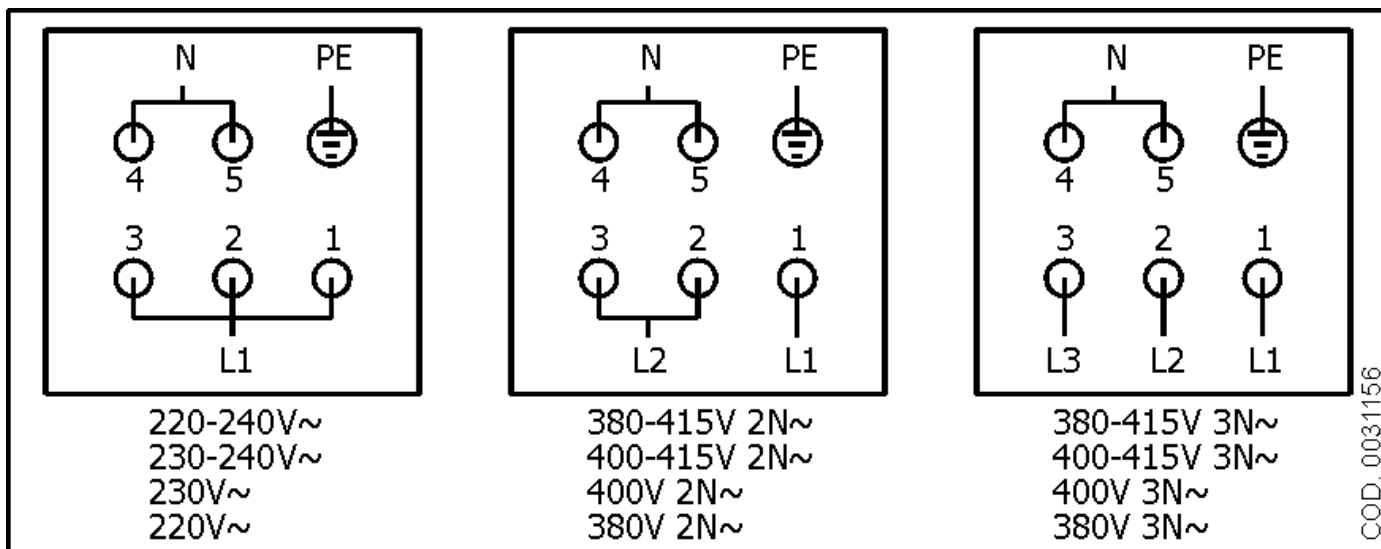

FIG. 10

COD. 0031156

SERVICING

Always disconnect the appliance from the electricity main before proceeding with any servicing operation.

REPLACING THE ELECTRICAL COMPONENTS

For access to the various parts, remove the hotplate from the top of the cabinet. Then overturn it, unscrew screw and remove under the bottom.

After these actions is possible to work on the plates, commutators, clamps and input cable.

For maintenance of the cable you need to reverse the hob.

N.B. In case of substitution of the input cable, the installer must keep the "earth" conductor longer than "live" ones, and must respect the cautions in paragraph "Electrical connection".

To reassemble the appliance repeat the inverse process.

WARNING: MAINTENANCE MUST ONLY BE PERFORMED BY AUTHORISED PERSONS.

In case of failure or cut in the cable, please move away from the cable and do not touch it. Moreover the device must be unplugged and not switched on. Call the nearest authorized service center to fix the problem.

TROUBLESHOOTING

If you encounter a problem, it frequently will merely be something minor. So, before you call customer service, consider the following suggestions and instructions:

The cooktop is not working →

Check the condition of the fuses/circuit breakers at your location. Check to see if you are experiencing a power failure.

The cooktop has turned itself off →

The main switch (ON/OFF key) was accidentally touched or there is any object above any key. Turn the unit on again without any object about the keyboard. Enter your settings again.

REPAIRS →

Repairs may only be performed by trained customer service technicians.

WARNING:
If your unit is repaired in an unprofessional manner, you may be exposed to substantial risks.

Display *F* and numbers →

If *F* and numbers appears in the display, your unit has detected a fault. The following table list actions you can take to correct the problem.

Heater display	Fault	Action
F0	Touch control software error.	If error has occurred after initial calibration disconnected and connect again the cooktop to the power supply. If error persist, call after-sales service. If error appears suddenly in a normal operation, call after-sales service.
Fc	Touch control zone is too hot and has turned off all the heaters.	Wait until temperature goes down. Cook-top will automatically recovered when temperature reaches a normal value.
Ft	Touch control temperature sensor can be damaged.	Wait until temperature goes down. If message persist when temperature reaches an environment value, call after-sales service.

TROUBLESHOOTING

Heater display	Fault	Action
FE	Touch control temperature sensor can be damaged.	Wait until temperature goes down. If message persist when temperature reaches an environment value, call after-sales service.
Fb	Excessive sensitivity on any key.	See if cook-top is mounted correctly. Be sure that keys touch correctly the glass surface.
FU / FJ	Security keyboard error	This error is a keyboard auto-check. It disappears when auto-check return to secure value. If error persist, call after-sale service.
FA	Security software error	This error is a software auto-check. It disappears when auto-check return to secure value. If error persist, call after-sale service.
FC / Fd	Security software error	This error is a software auto-check. It disappears when auto-check return to secure value. If error persist, call after-sale service.
Fr	Relays security error	Any relay driver can have any problemn. Remove cook-top from the power supply, wait a minute and switch on again. If error persist, call after-sale service.

TECHNICAL DATA

TYPE AND SECTION OF THE POWER CABLES (FOR 4/5 HEATING ELEMENTS)

TYPE OF HOBS	CABLE TYPE (rubber - polychloroprene)	Single phase power	Three phase power	Two phase power
		230 V~ 220 V~ 220-240 V~ 230-240 V~	400 V 3N~ 380 V 3N~ 380-415 V 3N~ 400-415 V 3N~	400 V 2N~ 380 V 2N~ 380-415 V 2N~ 400-415 V 2N~
Hob with 4 heating element "hi-light"	H05 RN - F	3 x 2.5 mm ² (*)	5 x 1 mm ² (*)	4 x 1.5 mm ² (*)
	H05 RR - F	3 x 2.5 mm ² (*)	5 x 1 mm ² (*)	4 x 1.5 mm ² (*)
	H07 RN - F	3 x 2.5 mm ² (*)	5 x 1 mm ² (*)	4 x 1.5 mm ² (*)
Hob with 5 heating element "hi-light"	H05 RN - F	3 x 2.5 mm ² (*)	5 x 1 mm ² (*)	4 x 1.5 mm ² (*)
	H05 RR - F	3 x 2.5 mm ² (*)	5 x 1 mm ² (*)	4 x 1.5 mm ² (*)
	H07 RN - F	3 x 2.5 mm ² (*)	5 x 1 mm ² (*)	4 x 1.5 mm ² (*)

Model BCC604T

MODEL 4 HEATING ELEMENTS (60 cm.) (4HI-LIGHT)	
Voltage	220 - 240/380 - 415 V 3N ~
Frequency	50/60 Hz or 50 Hz or 60 Hz
Tot. rating	6000 W

AUSTRALIAN & NEW ZEALAND PRODUCT WARRANTY STATEMENT OF STANDARD WARRANTY CONDITIONS

AUSTRALIAN CUSTOMERS

Our goods come with guarantees that cannot be excluded under the Australian Consumer Law. You are entitled to a replacement or refund for a major failure and for compensation for any other reasonably foreseeable loss or damage. You are also entitled to have the goods repaired or replaced if the goods fail to be of acceptable quality and the failure does not amount to a major failure.

NEW ZEALAND CUSTOMERS

Nothing herein contained shall be construed in any way as excluding or limiting your rights under the Consumer Guarantee Act 1993.

OUR WARRANTY

This product is also covered by the manufacturer's warranty set out in this document (**Our Warranty**).

Our Warranty is for a period of **twenty four (24) months** from the date of purchase and for dishwasher & refrigeration appliances will have an additional **thirty six (36) months** after the first **twenty four (24) months** on the wash motor for dishwashers & on the Sealed System (**PARTS only** Compressor & condenser etc) for refrigeration appliances. The labour cost to replace these parts is the responsibility of the customer.

This is in addition to (and does not exclude, restrict or modify) any rights or remedies to which you may already be entitled under the Australian consumer Law or the New Zealand Consumer Guarantee Act 1993 relating to this product.

Our Warranty (which is subject to the conditions below) covers rectification free of charge of any fault arising from defective materials or components, or faulty workmanship. The product will be repaired or replaced at the option of Blanco, and all costs of installation, removal, cartage, freight travelling expenses and insurance are to be paid by the customer.

Our Warranty is subject to the following conditions:

1. That the purchaser contact Blanco prior to any product repair.
2. That the purchaser carefully follows all instructions provided with the product and complies with all relevant electrical & plumbing regulations in their State when installing the product.
3. That the purchaser carefully follows the instructions provided in the owner's handbook relating to the proper use and care of the product and does not use the product for any purpose other than the DOMESTIC use for which it has been designed. If the appliance is used in commercial applications or for rental purposes, **Our Warranty** is limited to a warranty of **Twelve (12) months** covering all parts with **Three (3) months** on any labour cost of service or repair.

SERVICE AREA

The provision of service under **Our Warranty** is limited by the boundary / territory area of the nearest service centre. Travelling cost incurred for service outside this area is not covered by **Our Warranty** and service will incur commercial cost to be paid by the customer regulated by the number of kilometres travelled beyond the service area. These costs will be disclosed to you for acceptance by you prior to your claim being processed.

Microwave ovens must be returned to your nearest Authorised Service Centre for repair as they are a carry in serviceable appliance.

WHAT IS COVERED: By Our Warranty

During the warranty period, Blanco or its authorised Service Centre will at no extra charge, if your appliance is readily accessible without the need of special equipment and subject to the terms and conditions of this warranty, repair or replace any parts which it considers defective.

WHAT IS NOT COVERED: By Our Warranty

1. Products installed damaged or incomplete or not in compliance with the relevant electrical & plumbing regulations in their State.
2. Normal wear and tear e.g. cleaning, light globes, filters etc.
3. Failure resulting from power surges and electrical storms.
4. Insect or vermin infestation.
5. Unauthorised repairs or use of non genuine Blanco parts.
6. Any failure caused by the product not being used in accordance with the instruction and the installation manual provided with the product.
7. Misuse or abuse, including failure to properly maintain or service.
8. The clearing of blockages in pumps and hoses.
9. Damage which occurs during delivery or installation.
10. Claims to product surface coating due to liquid or solid spill-overs, accidental damage or damage caused from cleaning products not recommended by Blanco.

HOW TO CLAIM OUR WARRANTY

You will need to contact Blanco in Australia or New Zealand by using the contact details below.

IN AUSTRALIA

Blanco is distributed by Shriro Australia Pty Ltd

Locked Bag 5002, Kingsgrove, NSW, 2208 Phone:

1300 795 572 Fax: 1800 686 413

Email: customercare@shriro.com.au

Web: <http://www.blanco-australia.com/>

IN NEW ZEALAND

Blanco is distributed by Monaco Corporation
(Member of Shriro Australia Pty Ltd)

PO Box 4399, Shortland St, Auckland, 1140

Phone: 09 415 6000 Fax: 09 415 7060

Email: service@shriro.com.au

Web: <http://www.blanco-australia.com/>

Note: Please complete the following details when you have unpacked the product and staple this card with the purchase invoice or sales docket.

Model No.....

Serial No.....

Date of Purchase.....

Retailer.....