

WALL MOUNT STORAGE SHELF

410H x 1140W x 515Dmm

ITEM NO: GOS028

POWDER
COATED

80kg
PER SHELF

SAFETY TIP:

When assembling or installing this product wear protective gloves and eyewear.

Very Important: Unpack the unit and confirm that you have all the parts listed. Assemble the unit on a solid, level surface. Avoid carpet. You will need the assistance of a second person during assembly.
You will need the following: Rubber mallet, Phillips-head screwdriver, drill and an adjustable spanner.

Parts List

	(A) Frame	x1
	(B) Bracket	x1
	(C) Bracket	x1
	(D) Plastic wall plug	x6
	(E) Self-tapping screw	x6
	(F) Wing screw	x2
	(G) Wire shelf	x1

NOT TO SCALE

Step 1

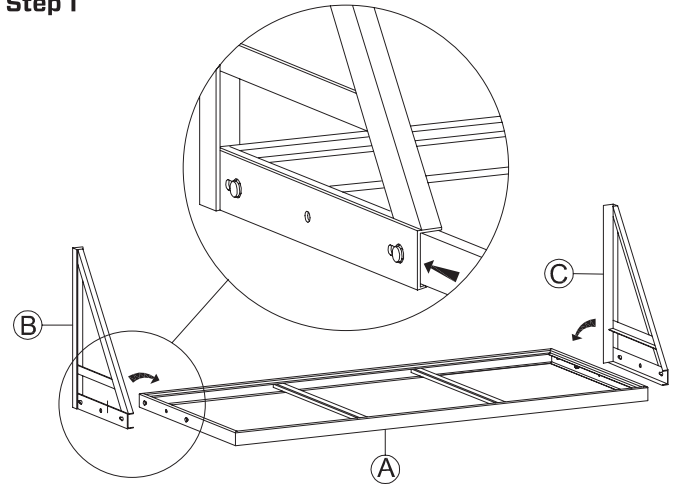

Slide bracket (B) onto frame (A). Use a rubber mallet to tap bracket into place if required. Repeat with bracket (C).

Before installing please determine the type of wall the shelf is to be affixed to. We recommend installation to a wall be undertaken by a qualified person.

Masonry/Concrete installation

Use appropriate size masonry drill bit for plug size (D). Drill six holes into masonry/concrete using parts (A, B, C) of shelf as template. Make sure holes are drilled into masonry, not mortar. Hold assembled shelf against wall, use self tapping screws (E) to affix to wall through wall plugs.

Stud wall installation

Before installing on a stud wall, mark location of studs. Drill six holes using parts (A, B, C) of shelf as a template. Hold assembled shelf against wall, use self-tapping screws (E) to affix to stud wall. Attach to solid masonry or solid timber studs only. If attaching to hollow walls you will need to add a horizontal piece of timber across 2 or 3 studs.

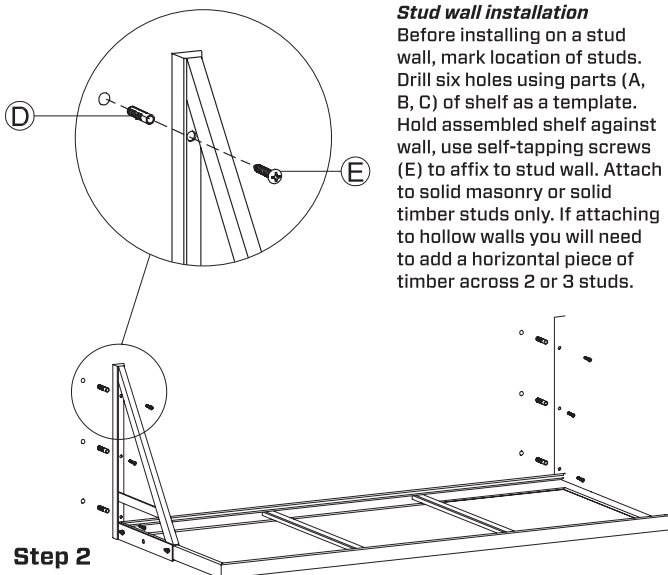

Step 2

Step 3

Lay wire shelf (G) on completed frame (A, B, C). Use wing screw (F) to lock the wire shelf in place.

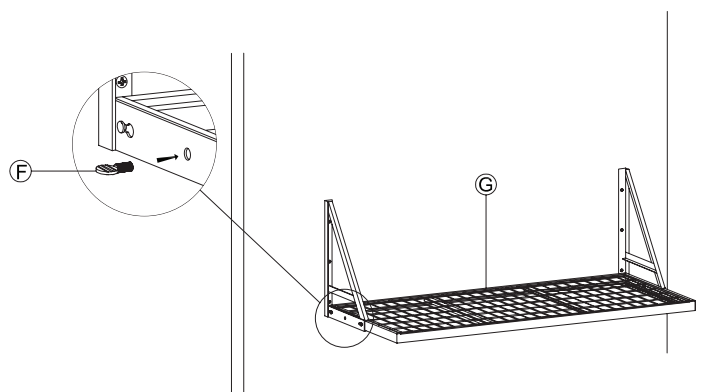

WARRANTY CONDITIONS

Any claim under this warranty must be made within 1 year of the date of purchase of the product. To make a claim under this warranty, take the product (with proof of purchase) to any Bunnings store (see www.bunnings.com.au for store locations). Pinnacle Hardware bears reasonable, direct expenses of claiming under the warranty. You may submit details and proof of purchase to our support centre for consideration. The warranty covers manufacturer defects in materials, workmanship and finish under normal use. This warranty is provided in addition to other rights and remedies you may have under law: Our goods come with guarantees that cannot be excluded under the Australian consumer law. You are entitled to a replacement or refund for a major failure and compensation for any other reasonably foreseeable loss or damage. You are also entitled to have the goods repaired or replaced if the goods fail to be of acceptable quality and the failure does not amount to a major failure. This warranty excludes damage resulting from product misuse or product neglect. The warranty covers domestic use only and does not apply to commercial applications. This warranty is given by Pinnacle Hardware, ABN 67 614 496 196, 28 Hudson Court, Keysborough Vic 3173, 1800 349 776, Email: support@pinnacle.net.au. New Zealand customers please contact HARCO (Harkness & Young Ltd), 09 27 64071, Email: sales@harknessyoung.co.nz. 'Pinnacle' is a trademark. © Pinnacle Hardware. Suitable for model number GOS028.