

RYOBI®

RPW3200

PETROL POWERED HIGH PRESSURE CLEANER OPERATOR'S MANUAL ORIGINAL INSTRUCTIONS

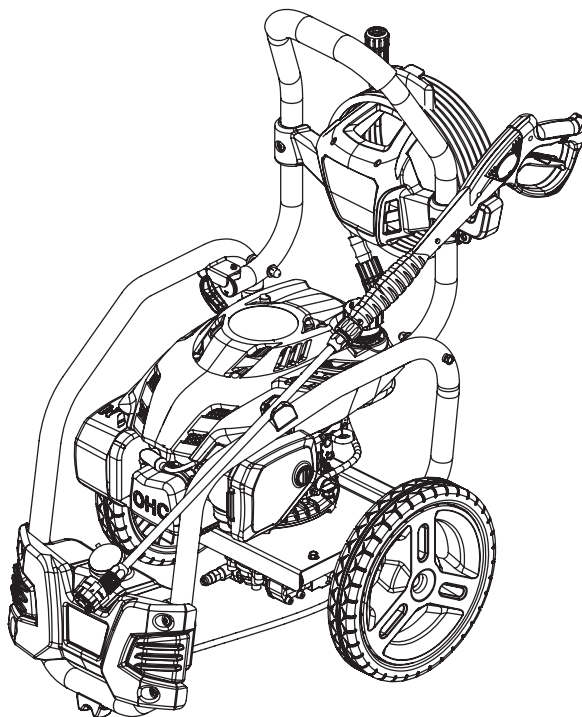

Important!

It is essential you read the instructions in this manual before starting and operating this machine.
Subject to technical modifications.



DESCRIPTION

- | | | |
|---|--|--------------------------------|
| 1. 5-in-1 Change Over Nozzle | 19. Hose storage | 35. Oil cap/dipstick |
| 2. Detergent tank | 20. Hex nut | 36. Upper fill level |
| 3. Spray wand | 21. Washer | 37. Funnel |
| 4. Fuel valve | 22. Trigger handle holder | 38. Recoil starter |
| 5. On/off switch | 23. Spray wand holder | 39. Choke Start position |
| 6. Choke lever | 24. Screw (1/4-20 x 1.77 in., T30 Torx head) | 40. Choke Run position |
| 7. Fuel cap | 25. Connector | 41. Fuel switch off position |
| 8. Trigger with lock out | 26. Inlet coupler | 42. Fuel switch on position |
| 9. Trigger handle | 27. Collar | 43. Engine switch on position |
| 10. High pressure hose | 28. Garden hose | 44. Engine switch off position |
| 11. High pressure hose storage | 29. Water intake coupling | 45. Lock out |
| 12. Air filter cover | 30. Filter | 46. Slot |
| 13. Fuel tank | 31. Air filter knob | 47. Quick-connect collar |
| 14. Handle | 32. 0.75mm (0.030 in.) plug gap | 48. Spray selector |
| 15. Starter grip with rope | 33. Oil filter hole | 49. Soap Long Range |
| 16. Muffler | 34. Air filter | 50. Soap Short Range |
| 17. Handle release knob | | 51. Container |
| 18. Screw (1/4-20 x 2.0 in., T30 Torx head) | | 52. Paper clip |

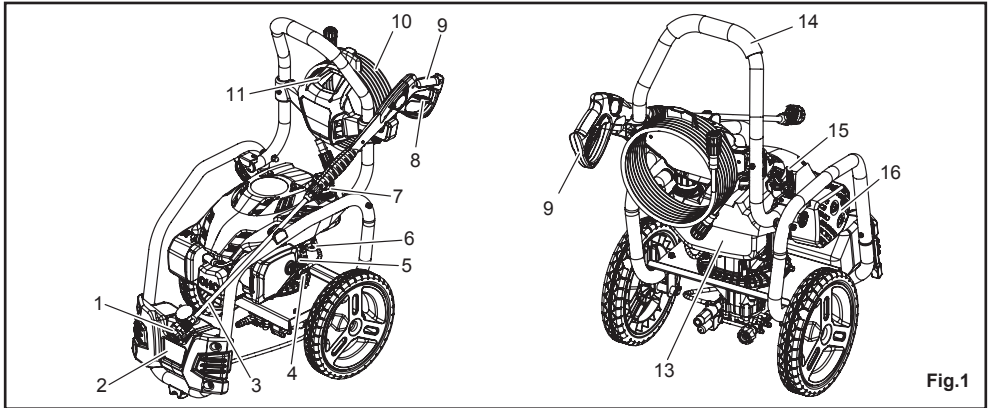

Fig.1

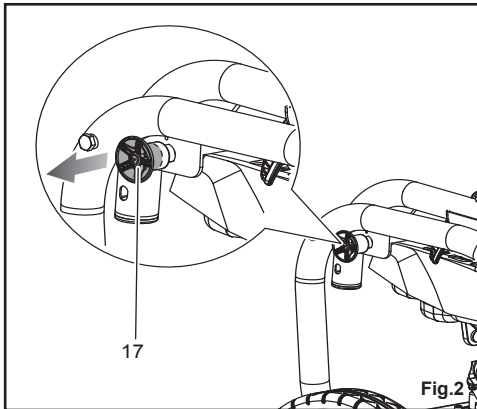

Fig.2

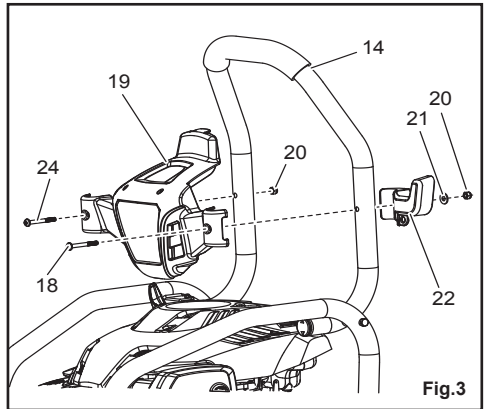
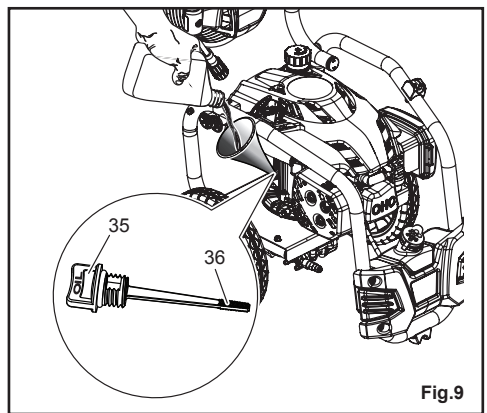
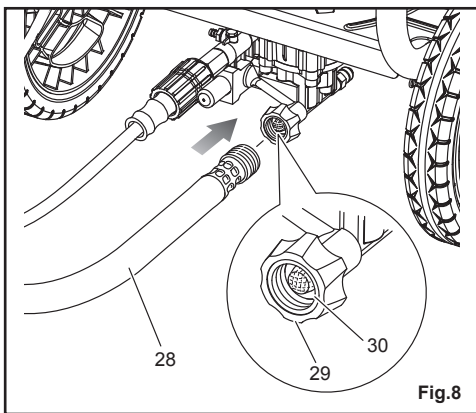
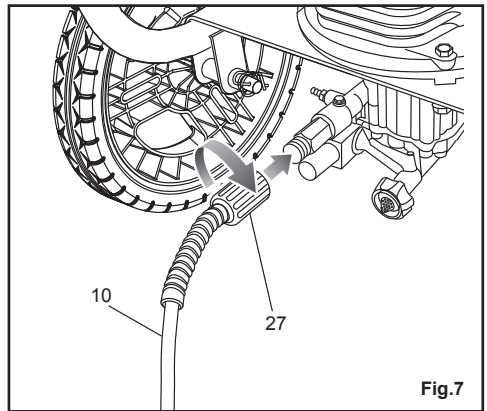
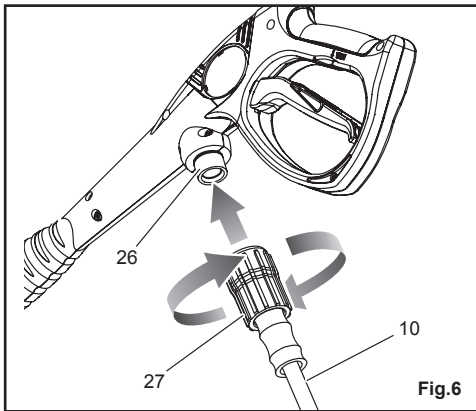
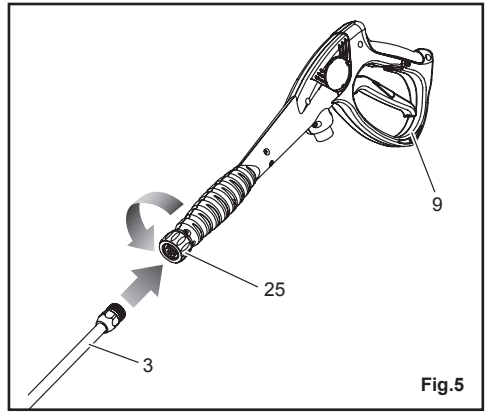
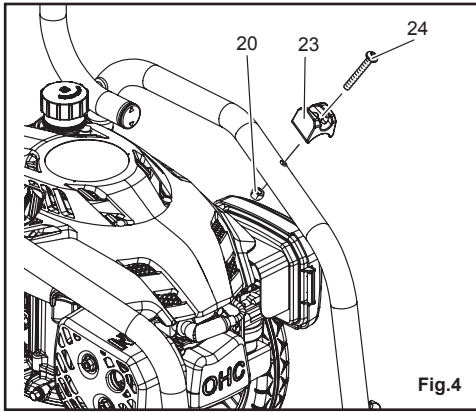
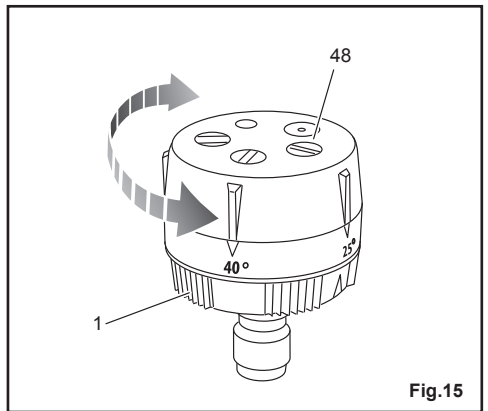
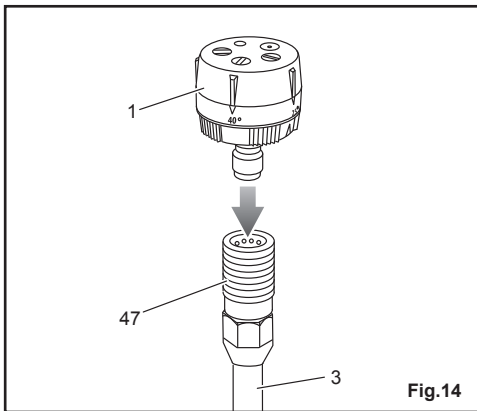
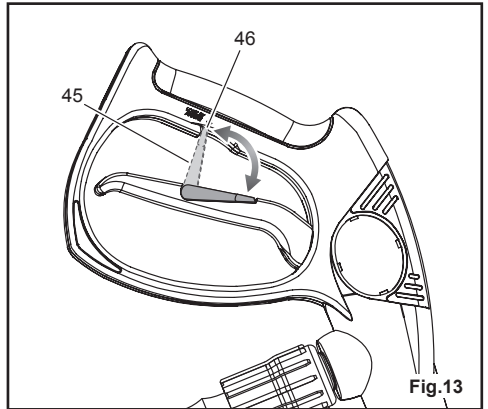
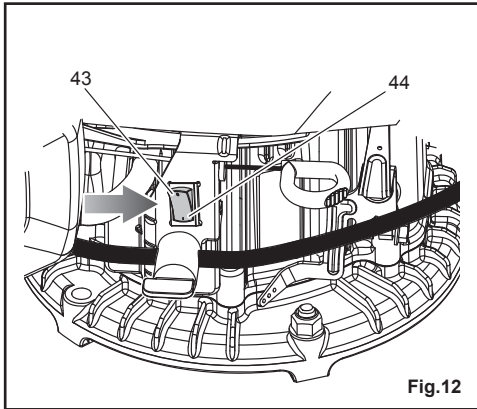
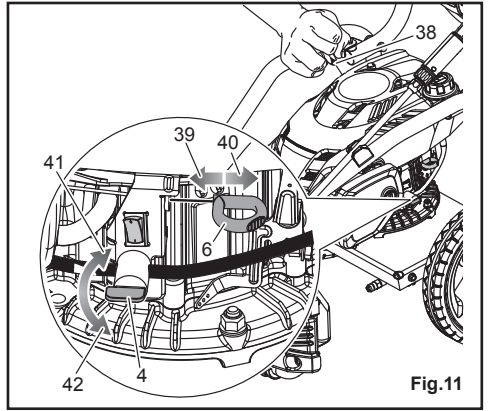
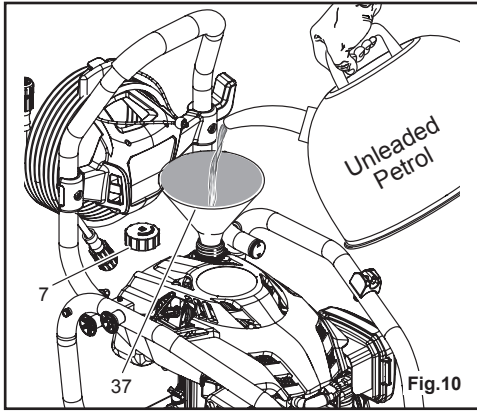

Fig.3





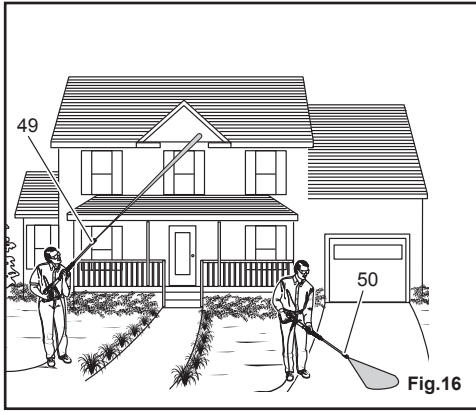

Fig.16

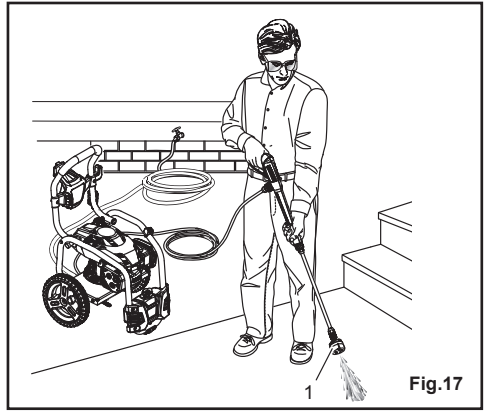

Fig.17

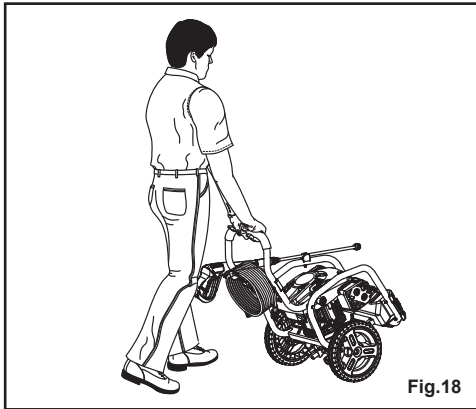

Fig.18

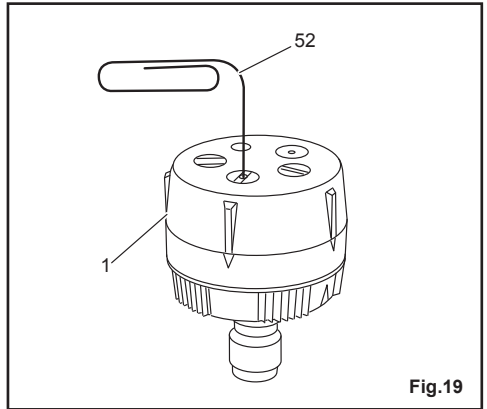

Fig.19

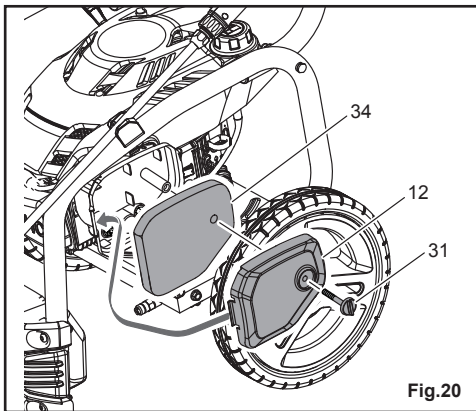

Fig.20

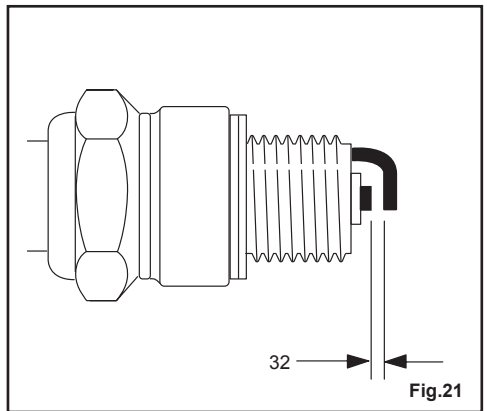
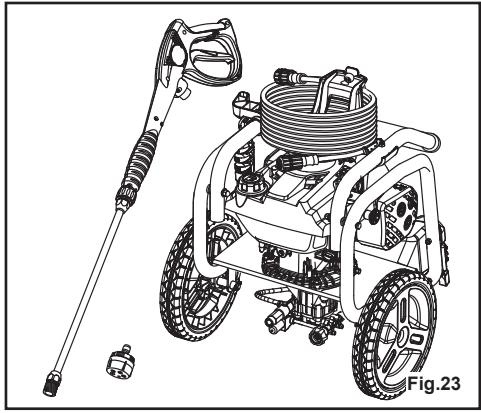
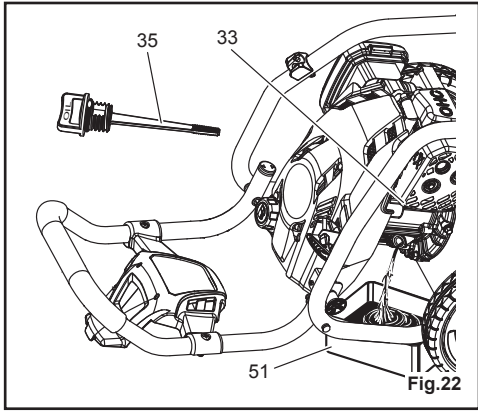

Fig.21



GENERAL SAFETY RULES

WARNING

Read and understand all instructions. Failure to follow all instructions listed below may result in electric shock, fire and/or carbon monoxide poisoning which will cause death or serious personal injury.

Read all instructions.

- **Know your tool.** Read the operator's manual carefully. Learn the machine's applications and limitations as well as the specific potential hazards related to this tool.
- **Keep guards in place** and in working order. Never operate the tool with any guard or cover removed. Make sure all guards are operating properly before each use.
- **Remove adjusting keys and wrenches.** Form habit of checking to see that keys and adjusting wrenches are removed from tool before turning it on.
- **To reduce the risk of injury,** keep children and visitors away. All visitors should wear safety glasses and be kept a safe distance from work area.
- **Keep the area of operation clear of all persons,** particularly small children, and pets.
- **Do not operate the engine in a confined space** where dangerous carbon monoxide fumes can collect. Carbon monoxide, a colorless, odorless, and extremely dangerous gas, can cause unconsciousness or death.
- **Use right tool.** Don't force tool or attachment to do a job it was not designed for. Don't use it for a purpose not intended.
- **Dress properly.** Do not wear loose clothing, gloves, neckties, or jewellery. They can get caught and draw you into moving parts. Rubber gloves and non-skid footwear are recommended when working outdoors. Also wear protective hair covering to contain long hair.
- **Do not operate the equipment while barefoot or when wearing sandals or similar lightweight footwear.** Wear protective footwear that will protect your feet and improve your footing on slippery surfaces.
- **Exercise caution to avoid slipping or falling.**
- **Always wear eye protection with side shields marked to comply with ANSI Z87.1.** Following this rule will reduce the risk of serious personal injury.
- **Don't overreach or stand on unstable support.** Keep proper footing and balance at all times.
- **Use only recommended accessories.** The use of improper accessories may cause risk of injury.
- **Follow the maintenance instructions specified in this manual.**

- **Check damaged parts.** Before further use of the tool, a guard or other part that is damaged should be carefully checked to determine that it will operate properly and perform its intended function. Check for alignment of moving parts, binding of moving parts, breakage of parts, mounting, and any other conditions that may affect its operation. A guard or other part that is damaged must be properly repaired or replaced by an authorised service center to avoid risk of personal injury.
- **Never leave tool running unattended.** Turn power off. Don't leave tool until it comes to a complete stop.
- **Keep the engine free of grass, leaves, or grease** to reduce the chance of a fire hazard.
- **Keep the exhaust pipe free of foreign objects.**
- **Follow manufacturer's recommendations for safe loading, unloading, transport, and storage of machine.**
- **Be thoroughly familiar with controls.** Know how to stop the product and bleed pressure quickly.
- **Keep tool dry, clean, and free from lubricant and grease.** Always use a clean cloth when cleaning. Never use brake fluids, gasoline, petroleum-based products, or any solvents to clean tool.
- **Stay alert and exercise control.** Watch what you are doing and use common sense. Do not operate tool when you are tired. Do not rush.
- **Do not operate the product while under the influence of drugs, alcohol, or any medication.**
- **Check the work area before each use.** Remove all objects such as rocks, broken glass, nails, wire, or string which can be thrown or become entangled in the machine.
- **Do not use tool if switch does not turn it off.** Have defective switches replaced by an authorised service center.
- **Before cleaning, repairing, or inspecting,** shut off the engine and make certain all moving parts have stopped. Disconnect the spark plug wire, and keep the wire away from the plug to prevent accidental starting.
- **Avoid dangerous environment.** Don't use in damp or wet locations or expose to rain. Keep work area well lit.
- **Never use in an explosive atmosphere.** Normal sparking of the motor could ignite fumes.
- **Do not operate while smoking or near an open flame.**
- **Do not operate** around dry brush, twigs, cloth rags, or other flammable materials.

WARNING

Risk of injection or injury – Do not direct discharge stream at persons.

SPECIAL SAFETY RULES

- **Never direct a water stream toward people or pets, or any electrical device.**
- **Before starting any cleaning operation**, close doors and windows. Clear the area to be cleaned of debris, toys, outdoor furniture, or other objects that could create a hazard.
- **Never pick up or carry a machine while the engine is running.**
- **Never start the machine** if ice has formed in any part of the equipment.
- **Do not use acids, alkalines, solvents, flammable material, bleaches, or industrial grade solutions** in this product. These products can cause physical injuries to the operator and irreversible damage to the machine.
- **Always operate the machine on a level surface.** If the engine is on an incline, it could seize due to improper lubrication (even at the maximum lubricant level).

⚠ WARNING

High pressure jets can be dangerous if subject to misuse. The jet must not be directed at persons, animals, electrical devices, or the machine itself.

- **Hold the handle and wand securely with both hands.** Expect the trigger handle to move when the trigger is pulled due to reaction forces. Failure to do so could cause loss of control and injury to yourself and others.
- **Never attempt to make any adjustments while the engine (motor) is running** (except where specifically recommended by the manufacturer).
- **Protective covers must always cover rotating parts when the engine is running.**
- **Keep cooling air intake** (recoil starter area) and muffler side of the engine at least 1m (3 feet) away from buildings, obstructions, and other combustible objects.
- **Keep the engine away from flammables and other hazardous materials.**
- **Keep away from hot parts.** The muffler and other engine parts become very hot; use caution.
- **Do not touch the spark plug and ignition cable** when starting and operating the engine.
- **Check fuel hoses and joints** for looseness and fuel leakage before each use.
- **Check bolts and nuts** for looseness before each use. A loose bolt or nut may cause serious engine problems.
- **Always refuel outdoors.** Never refuel indoors or in a

poorly ventilated area.

- **Never store the machine with fuel in the fuel tank inside a building** where ignition sources are present, such as hot water and space heaters, clothes dryers, and the like.
- **If the fuel tank has to be drained, do this outdoors.**
- **To reduce the risk of fire and burn injury**, handle fuel with care. It is highly flammable.
- **Do not smoke while handling fuel.**
- **Add fuel before starting the engine.** Never remove the cap of the fuel tank or add fuel while the engine is running or when the engine is hot.
- **Loosen fuel cap slowly** to release pressure and to keep fuel from escaping around the cap.
- **Replace all fuel tank and container caps securely.**
- **Wipe spilled fuel from the unit.** Move 9m (30 feet) away from refuelling site before starting engine.
- **If fuel is spilled**, do not attempt to start the engine but move the machine away from the area of spillage and avoid creating any source of ignition until fuel vapors have dissipated.
- **Never attempt to burn off spilled fuel under any circumstances.**
- **Before storing, allow the engine to cool and drain fuel from the unit.**
- **Store fuel in a cool, well-ventilated area**, safely away from spark and/or flame-producing equipment.
- **Store fuel in containers** specifically designed for this purpose.
- **Empty fuel tank and restrain the unit from moving** before transporting in a vehicle.
- **When servicing use only original replacement parts.** Use of any other parts may create a hazard or cause product damage.
- **Only use cold water.**
- **Make sure minimum clearance** of 1m (3 feet) is maintained from combustible materials.
- **Never spray close to the surface** to be cleaned as you can damage the surface.
- **After stopping the engine, always pull the trigger on the trigger handle to relieve stored pressure in the high pressure hose.** Failure to do so could result in serious personal injury.
- **For outdoor use only.**
- **Ensure the high pressure hose is properly connected before using the product.**
- **Save these instructions.** Refer to them frequently and use them to instruct other users. If you loan someone this tool, loan them these instructions also.

SYMBOLS



Safety alert



Please read the instructions carefully before starting the machine.



Wear eye, hearing and head protection when operating this equipment.



To reduce the risk of injection or severe injury, do not direct spray at persons or animals.



Fuel and its vapors are extremely flammable and explosive. Fire can cause severe burns or death.



To reduce the risk of injury from kickback, hold the spray wand securely with both hands when the machine is on.



Petrol products emit carbon monoxide, an odourless, colourless, poison gas. Breathing carbon monoxide can cause nausea, fainting, or death.



Failure to use in dry conditions and to observe safe practices can result in electric shock.



Fuel and its vapors are explosive and can cause severe burns or death.



Must not be directed at persons, live electrical equipment



Add lubricant to full mark to start. Engine will not start or will shut off if lubricant is too low.



Appliance not suitable for connection to the drinking water mains without backflow preventer.



Guaranteed sound pressure and sound power level.



Regulatory Compliance Mark (RCM). This product meets applicable regulatory requirements.



Waste electrical products should not be disposed of with household waste. Please recycle where facilities exist. Check with your Local Authority or retailer for recycling advice.

The following signal words and meanings are intended to explain the levels of risk associated with this product.

Symbol	Signal	Meaning
	DANGER:	Indicates an imminently hazardous situation, which, if not avoided, will result in death or serious injury.
	WARNING:	Indicates a potentially hazardous situation, which, if not avoided, could result in death or serious injury.
	CAUTION:	Indicates a potentially hazardous situation, which, if not avoided, may result in minor or moderate injury.
	NOTICE:	(Without Safety Alert Symbol) Indicates important information not related to an injury hazard, such as a situation that may result in property damage.

PRODUCT SPECIFICATIONS

Product weight and dimension	
Product weight (kg)	29
Width (mm)	530
Length (mm)	620
Height - Handle folder (mm)	600
Height - Handle open (mm)	960
Pressure washer specifications	
Maximum pressure (MPa)	22
Maximum pressure (psi)	3200
Rated pressure (MPa)	21
Rated pressure (psi)	3050
Maximum flow rate (l/m)	9.5
Maximum flow rate (g/m)	2.5
Maximum inlet pressure (MPa)	40
Maximum inlet pressure (psi)	100
Minimum inlet pressure (MPa)	0.7

Engine specifications	
Engine manufacturer	Subaru
Engine model	EA190VP0037
Engine type	4-stroke Air- cooled OHC
Bore and stroke	68mm / 52mm
Displacement	189cc
Starting system	Recoil
Fuel type	Automobile Gasoline Unleaded
Fuel tank capacity (l)	1.2
Lubrication oil type	Automobile Oil 10W-30, Class SE or higher
Engine oil capacity (l)	0.6
Noise specifications	
Uncertainty (dB)	2
Noise level LpA dB (A)	93.5
Noise level LwA dB (A)	108
Vibration level	
Uncertainty	$K = 0.5 \text{ m/s}^2$
Vibration level	$ah = 3.97 \text{ m/s}^2$

INTENDED USE

You may use this tool for the purposes listed below:

- Removing dirt and mold from decks, cement patios, and house siding.
- Cleaning boats, outdoor furniture, and grills

FEATURES

KNOW YOUR PRESSURE WASHER

See figure 1.

The safe use of this product requires an understanding of the information on the tool and in this operator's manual as well as a knowledge of the project you are attempting. Before use of this product, familiarize yourself with all operating features and safety rules.

5-IN-1 CHANGE OVER NOZZLE

The 5-in-1 Change Over Nozzle makes it easy to change spray patterns.

FUEL TANK

This fuel tank has a maximum capacity of 1.2l (0.32 US gal). Use unleaded automotive fuel in the engine.

FUEL VALVE

The fuel valve must be open to start the engine and should always be closed before storing the machine.

HOSE STORAGE

Once the high pressure hose is rolled, hang it on the back of the machine using the hook-and-loop strap to secure in place.

ON/OFF SWITCH

The on/off switch is used in combination with the starter grip and rope to start the engine. It is also used to turn the engine off.

STARTER GRIP WITH ROPE

The starter grip with rope is pulled to start the machine.

SPARK ARRESTOR

This engine is factory equipped with a spark arrestor. In some areas it is illegal to operate an engine without a spark arrestor.

THERMAL RELIEF VALVE

This pump feature will prevent water temperatures from reaching harmful levels by releasing a small amount of water. Once the water has drained, the thermal relief valve will reset itself.

TRIGGER HANDLE

The trigger handle has a gripping surface that provides added control of the spray wand and helps reduce fatigue.

TRIGGER WITH LOCK OUT

Pulling the trigger releases a stream of water for high pressure cleaning. The lock out provides protection against unauthorised use.

ASSEMBLY

UNPACKING

This product requires assembly.

- Carefully remove the product and any accessories from the box. Make sure that all items listed in the packing list are included.

WARNING

Do not use this product if any parts on the Packing List are already assembled to your product when you unpack it. Parts on this list are not assembled to the product by the manufacturer and require customer installation. Use of a product that may have been improperly assembled could result in serious personal injury.

NOTE: This tool is heavy. To avoid back injury, lift with your legs, not your back, and get help when needed.

- Inspect the tool carefully to make sure no breakage or damage occurred during shipping.
- Do not discard the packing material until you have carefully inspected and satisfactorily operated the tool.

PACKING LIST

- Pressure Washer
- 7.6m (25 ft.) High Pressure Hose
- Trigger Handle Holder
- Trigger Handle
- Screw (1/4-20 x 1.77 in., T30 Torx head) x2
- Screw (1/4-20 x 2.0 in., T30 Torx head)
- Flat Washer
- Hex nut (1/4-20 in.) x3
- Spray Wand
- 5-in-1 Change Over Nozzle
- 4-Cycle Engine Lubricant (SAE 30 or SAE 10W30)
- Hose Storage
- Operator's Manual

TOOLS NEEDED

The following tools (not included or drawn to scale) are needed for assembly:

- 7/16 in. wrench
- T30 head screwdriver

WARNING

If any parts are damaged or missing do not operate this product until the parts are replaced. Use of this product with damaged or missing parts could result in serious personal injury.

WARNING

Do not attempt to modify this product or create accessories not recommended for use with this product. Any such alteration or modification is misuse and could result in a hazardous condition leading to possible serious personal injury.

WARNING

To prevent accidental starting that could cause serious personal injury, always disconnect the engine spark plug wire from the spark plug when assembling parts.

RAISING AND LOWERING THE HANDLE

See figure 2.

- To raise the handle (for moving the pressure washer): pull the handle up until the handle release knob snaps into locking position. Ensure the lock is secured in the frame hole before moving.
- To lower the handle (for storing or transporting the pressure washer): pull the handle release knob out and lower the handle to the down position.

NOTE: The handle can not be locked in the down position.

Never use the handle to lift the pressure washer. The handle should only be used for moving the unit by rolling it on its wheels.

INSTALLING HOSE STORAGE, TRIGGER HANDLE HOLDER, AND SPRAY WAND HOLDER

See figures 3 - 4.

- Raise handle as described in the Raising and Lowering Handle section.
- Place hose storage onto the handle as shown.
- Align the holes in the hose storage with the holes in the handle.
- Insert screw (1/4-20 x 1.77 in.) through the holes in the left side of the handle and hose storage.
- Place nut onto bolt and tighten.
- Place the trigger handle holder onto the handle as shown.
- Align the holes in the trigger handle holder with the holes in the hose storage and the handle.
- Insert screw (1/4-20 x 2.0 in.) through the holes in handle, hose storage, and trigger handle holder.
- Turn bolt while holding the nut in place to tighten and secure.
- Place spray wand holder onto pressure washer frame.
- Align the holes in the spray wand holder with the holes in the pressure washer frame.
- Insert screw (1/4-20 x 1.77 in.) through the holes in the spray wand holder and the pressure washer frame.
- Place nut onto screw and tighten.

ASSEMBLING THE SPRAY WAND TO THE TRIGGER HANDLE

See figure 5.

- Place the threaded end of the spray wand in the

connector on the end of the trigger handle.

- Turn the connector clockwise until it stops. This secures the spray wand in place.

CONNECTING HIGH PRESSURE HOSE TO TRIGGER HANDLE

See figure 6.

- Screw the collar on the high pressure hose into the trigger handle inlet coupler by turning the hose collar clockwise.
- Pull on the hose to be certain it is properly secured.

CONNECTING THE HIGH PRESSURE HOSE TO THE PUMP

See figure 7.

After the high pressure hose has been uncoiled and attached to the spray wand:

- Align the collar on the threaded nipple on the pump.
- Insert the nozzle on the end of the high pressure hose collar into the threaded nipple.
- Turn the collar clockwise to tighten the hose securely to the pump.
- Pull on the hose to be certain it is properly secured.

CONNECTING THE GARDEN HOSE TO THE PRESSURE WASHER

See figure 8.

The water supply must come from the mains. Never use hot water or water from ponds, lakes, etc. Before connecting the garden hose to the pressure washer:

- Run water through the hose for 30 seconds to clean any debris from the hose.
- Inspect the filter in the pressure washer water intake.
- If the filter is damaged, do not use the pressure washer until the filter has been replaced.
- If the filter is dirty, clean it before connecting the garden hose to the pressure washer.

To connect the garden hose to the pressure washer:

- Uncoil the garden hose.

NOTE: There must be a minimum of 3 metres of unrestricted hose between the pressure washer intake and the garden tap.

- Attach the threaded hose coupler to the pressure washer water intake and hand tighten.
- With the garden tap turned completely off, attach the end of the garden hose adapter (not supplied) to the hose coupler.

OPERATION

⚠ WARNING

Do not allow familiarity with this product to make you careless. Remember that a careless fraction of a second is sufficient to inflict serious injury.

⚠ WARNING

Always wear eye protection with side shields marked to comply with one of the following standards:

- Australian standard -- AS/ NZS 1337
- European standard -- CE EN166
- American standard -- ANSI Z87.1

Failure to do so could result in objects being thrown into your eyes resulting in possible serious injury.

⚠ WARNING

Do not use any attachments or accessories not recommended by the manufacturer of this product. The use of attachments or accessories not recommended can result in serious personal injury.

⚠ WARNING

Never direct a water stream toward people or pets, or any electrical device. Failure to heed this warning could result in serious injury.

ADDING LUBRICANT TO THE ENGINE

See figure 9.

NOTE: This machine has been shipped with approximately 0.06l (2 oz.) of lubricant in the engine from testing. **You must add lubricant to the engine before starting it the first time.**

⚠ CAUTION

Any attempt to start the engine without adding lubricant will result in engine failure.

- Place pressure washer on a flat, level surface.
- Unscrew the lubricant cap / dipstick by turning counterclockwise.
- Using 4-stroke engine lubricant (SAE 30 or SAE 10W30), add engine lubricant until the fluid level rises to the upper portion of the hatched area on the dipstick (18 oz., 4-cycle engine lubricant provided). **Do not overfill.**

NOTE: Level is checked without screwing the dipstick in.

- Replace the lubricant cap / dipstick and securely tighten.

NOTE: This engine has a total lubricant capacity of 0.6l (20 oz).

OXYGENATED FUELS

Do not use E85 fuel. It will void your warranty.

NOTE: Fuel system damage or performance problems resulting from the use of an oxygenated fuel containing more than the percentages of oxygenates stated below **are not covered under warranty.**

Ethanol. Gasoline containing up to 10% ethanol by volume (commonly referred to as E10) is acceptable. E85 is not.

ADDING GASOLINE TO THE FUEL TANK

See figure 10.

⚠ WARNING

Gasoline and its vapors are highly flammable and explosive. To prevent serious personal injury and property damage, handle gasoline with care. Keep away from ignition sources, handle outdoors only, do not smoke while adding fuel, and wipe up spills immediately.

When adding petrol to the pressure washer, make sure the unit is sitting on a flat, level surface. If the engine is hot, let the pressure washer cool before adding gas. Always fill the fuel tank outdoors with the machine turned off.

NOTE: Use unleaded petrol only. Do not mix lubricant with petrol.

- Before removing the fuel cap, clean the area around it. Remove the fuel cap.
- Insert a clean funnel into the fuel tank then slowly pour gasoline into the tank. Fill tank to approximately 40mm (1-1/2 in.) below the top of the tank neck (this allows for fuel expansion).
- Replace fuel cap and tighten until the cap “clicks”.
- Clean up any spills before starting the engine.

⚠ WARNING

Always shut off engine before fuelling. Never add fuel to a machine with a running or hot engine. Move at least 9m (30 ft.) from refuelling site before starting engine. Do not smoke and stay away from open flames and sparks! Failure to follow these instructions could result in serious personal injury.

STARTING AND STOPPING THE PRESSURE WASHER

See figures 11 - 12.

⚠ CAUTION

Do not run the pressure washer pump without water supply connected and turned on, as this may damage the high pressure seals and decrease pump life. Completely unwind the hose from its reel or coil and make sure the hose is not being restricted by tires, rocks, or any other objects that may lessen or prevent water flow to the pressure washer.

Before starting the engine:

- Connect all hoses.
- Check all fluids (lubricant and fuel).
- Turn on the garden hose then squeeze the trigger to relieve air pressure; hold the trigger until a steady stream of water appears.

To start the engine:

- Turn the fuel valve to the ON (horizontal) position.
- Put the on/off switch in the ON position.
- Push choke into the START position.
- Grasp the starter grip with rope and pull slowly until resistance is felt. Give the starter grip with rope a short, brisk pull to start the engine.

NOTE: Do not allow the starter grip with rope to snap back after starting; return it gently to its original place.

⚠ CAUTION

If the engine does not start after each pull of the starter grip with rope, squeeze the trigger to relieve water pressure before attempting to start the engine again.

- Let engine run for several seconds, then gradually slide the choke lever fully toward the RUN position.

To stop the engine:

- Put the on/off switch in the OFF position.
- Turn the fuel valve to the OFF (vertical) position.
- Shut off the water supply and pull trigger to release water pressure.

⚠ WARNING

Hold the handle and wand securely with both hands. Expect the trigger handle to move when the trigger is pulled due to reaction forces. Failure to do so could cause loss of control and injury to yourself and others.

WARNING

While operating and storing, keep at least 1m (3 feet) of clearance on all sides of this product, including overhead. Allow a minimum of 30 minutes of "cool down" time before storage. Heat created by muffler and exhaust gases may be hot enough to cause serious burns and/or ignite combustible objects.

USING THE SPRAY WAND TRIGGER

See figure 13.

- Pull back and hold the trigger to operate the pressure washer.
- Release the trigger to stop the flow of water through the nozzle.

To engage the lock out:

- Push up on the lock out until it clicks into the slot.

To disengage the lock out:

- Push the lock out down and into its original position.

For the most effective cleaning, the spray nozzle should be between 200 mm (8 in.) and 600 (24 in.) from the surface to be cleaned. If the spray is too close it can damage the cleaning surface.

INSTALLING/REMOVING NOZZLES

See figure 14.

WARNING

Never change nozzles or spray patterns without locking the lock out on the trigger handle and never point the wand at your face or at others. The quick-connect feature contains small springs that could eject the nozzle with some force. Failure to heed this warning could cause personal injury.

Using the quick-connect collar, changing the nozzle is easy.

To connect the nozzle to the trigger handle:

- Turn off the pressure washer and shut off the water supply. Pull trigger to release water pressure.
- Engage the lock out on the trigger handle by pushing up on the lock out until it clicks into the slot.
- Push the nozzle into the quick-connect collar until it clicks in place and is secured properly.

To disconnect a nozzle from the trigger handle once the cleaning job is complete:

- Turn off the pressure washer and shut off the water supply. Pull trigger to release water pressure.
- Engage the lock out on the trigger handle by pushing

up on the lock out until it clicks into the slot.

- Remove the nozzle by placing hand over nozzle then pulling back the quick-connect collar.

USING THE 5-IN-1 CHANGE OVER NOZZLE

See figure 15.

There are five spray pattern settings located on the 5-in-1 Change Over Nozzle. To select a spray pattern, rotate the spray selector to the desired setting.

Nozzle	Application
0°	Spot cleaning of high, hard-to-reach areas <ul style="list-style-type: none">● Removing caked-on mud from heavy construction, farm, or lawn equipment● Cleaning tar, glue, or stubborn stains from concrete● Cleaning overhead areas● Removing rust from steel and oxidation from aluminum
25°	For general purpose or large surfaces <ul style="list-style-type: none">● General cleaning of dirt, mud, and grime● Cleaning roofs, gutters, and downspouts● Removing light mildew stains● Removing algae and bacteria build-up from pools● Rinsing surfaces in preparation for painting
40°	For wide-angle rinsing <ul style="list-style-type: none">● Light cleaning and washing● Washing and rinsing of painted surfaces and boats● Cleaning roofs, windows, patios, and driveways
Soap short range	For short range detergent applications <ul style="list-style-type: none">● Driveways, walkways, decks and patios, vehicles, fences, paint prep, patio furniture, and lawn equipment
Soap long range	For long range detergent applications <ul style="list-style-type: none">● Second story washing

USING THE HIGH PRESSURE HOSE

The high pressure hose features an outer covering that provides strength to the hose. If the outer covering becomes damaged, the hose must be replaced immediately. **Do not use a high pressure hose if the outer covering is damaged.**

To prevent damage to the outer covering:

- Inspect the hose before every use.
- Fully unwrap and straighten hose before use.
- Do not allow the high pressure hose to be kinked.
- Keep hose away from hot surfaces and sharp edges.
- Do not pull unit by high pressure hose.
- Do not allow hose to be crushed or wrapped around objects.

WASHING WITH DETERGENT

See figures 16 - 17.

As sold, this unit is designed for use with “downstream” pressure washer detergents. To convert for use with “upstream” detergents, contact an authorised customer service center for more information.

Use only detergents designed for pressure washers; household detergents, acids, alkalines, bleaches, solvents, flammable material, or industrial grade solutions can damage the pump. Many detergents may require mixing prior to use. Prepare cleaning solution as instructed on the solution bottle.

- Remove the cap from the detergent container and pour detergent in the container. Replace cap on container.
NOTE: The machine setting of this unit is 1:20, which usually allows the use of 3.8l (1 US gallon) detergent without further dilution. Check your detergent instructions to be sure additional dilution is not necessary.
- Rotate the spray selector on the 5-in-1 Change Over Nozzle to either the Soap Short Range or Soap Long Range setting.
- Spray the detergent on a dry surface using long, even, overlapping strokes. To prevent streaking, do not allow detergent to dry on the surface.

For long range detergent application:

With the nozzle installed on the spray wand and the engine shut off, rotate the spray selector to the Soap Long Range setting.

For short range detergent application:

With the nozzle installed on the spray wand and the engine shut off, rotate the spray selector to the Soap Short Range setting.

Before shutting off the engine:

- Place the 5-in-1 nozzle to the 40° outlet position.
- Flush for 1 - 2 minutes (spray clear water through the spray wand).
- Shut off the engine.

NOTE: Shutting off (O) the engine will not relieve pressure in the system. Pull trigger to release water pressure.

RINSING WITH THE PRESSURE WASHER

- Turn off the pressure washer and shut off the water supply. Pull trigger to release water pressure.
- Engage the lock out on the trigger handle by pushing up on the lock out until it clicks into the slot.
- Rotate the spray selector on the 5-in-1 Change Over Nozzle to either the [40°], [25°], or [0°] setting depending on the job. Refer to the chart in **Using the 5-in-1 Change Over Nozzle** to determine which setting is correct for your application.

- When using these settings, test a small area first to avoid surface damage.
- Start at the top of the area to be rinsed and work down, overlapping the strokes.

MOVING THE PRESSURE WASHER

See figure 18.

NOTE: Never lift or carry this product using the handle and never place the unit in any position other than upright on its wheels.

- Turn the pressure washer off and ensure the fuel valve is closed.
- Pull the handle up until the handle release knob snaps into the locking position (if not already up and locked). Ensure the lock is secured in the frame hole before moving.
- Tilt the machine toward you until it balances on the wheels then roll the machine to the desired position.

For long term storage, see **Storing the Pressure Washer** in the Maintenance section of this manual.

MAINTENANCE

⚠ WARNING

When servicing, use only original manufacturer's replacement parts. Use of any other parts may create a hazard or cause product damage.

⚠ WARNING

Always wear eye protection with side shields marked to comply with one of the following standards:

- Australian Standard – AS/NZS 1337
- European Standard – CE EN166
- American Standard – ANSI Z87.1

Failure to do so could result in objects being thrown into your eyes resulting in possible serious injury.

⚠ WARNING

Before inspecting, cleaning or servicing the machine, shut off engine, wait for all moving parts to stop, and disconnect spark plug wire and move it away from spark plug. Failure to follow these instructions can result in serious personal injury or property damage.

GENERAL MAINTENANCE

Avoid using solvents when cleaning plastic parts. Most plastics are susceptible to damage from various types of commercial solvents and may be damaged by their use. Use clean cloths to remove dirt, dust, lubricant, grease, etc.

WARNING

Do not at any time let brake fluids, gasoline, petroleum-based products, penetrating lubricants, etc., come in contact with plastic parts. Chemicals can damage, weaken or destroy plastic which may result in serious personal injury.

Only the parts shown on the parts list are intended to be repaired or replaced by the customer. All other parts should be replaced at an authorized service center.

Before running the engine, perform the following preoperation steps:

- Check that all bolts, nuts, etc., are securely tightened.
- Make sure the air filter is clean.
- Check both the engine lubricant level and the fuel tank level; refill as needed.
- Inspect the work area for hazards.
- If there is excessive noise or vibration, stop the unit immediately.

NOZZLE MAINTENANCE

See figure 19.

Excessive pump pressure (a pulsing sensation felt while squeezing the trigger) may be the result of a clogged or dirty nozzle.

- Turn off the pressure washer and shut off the water supply. Pull trigger to release water pressure.
- Remove the nozzle from the spray wand.
NOTE: Never point the spray wand at your face.
- Using a straightened paper clip or nozzle cleaning tool (not provided), free any foreign materials clogging or restricting the nozzle.
- Using a garden hose, flush debris out of nozzle by back flushing (running the water through the nozzle backwards or from the outside to the inside).
- Reconnect the nozzle to the spray wand.
- Turn on the water supply and start the engine.

CLEANING THE AIR FILTER

See figure 20.

A dirty air filter will cause starting difficulty, loss of performance, and shorten the life span of the engine. Check the air filter monthly. For best performance, replace the air filter at least once a year.

- Unscrew air filter knob, then remove the air filter cover.
- Lift the edge of the air filter carefully and pull it out.
- Wash the air filter with warm, soapy water.
- Rinse and squeeze to dry.
- Reinstall the air filter.

NOTE: Make sure the filter is seated properly inside

the cover. Installing the filter incorrectly will allow dirt to enter the engine, causing rapid engine wear.

- Reinstall the air filter cover.

CHECKING SPARK PLUG

See figure 21.

- Clean the area around the base of the spark plug before removing to keep dirt and debris out of the engine. Remove spark plug.
- Clean off carbon deposits on the spark plug electrode using a plug cleaner or wire brush. Replace the plug if worn. (Recommended spark plug: BPR6HS (NGK) or equivalent.)
- Check electrode gap. The gap should be .03 in. (0.7-0.8 mm). Adjust the gap, if necessary, by carefully bending the ground electrode.
- Reinstall spark plug. Tighten securely.

CHANGING ENGINE LUBRICANT

See figure 22.

- Shut off the engine.
- Clean the area around the lubricant fill cap/dipstick, then remove the lubricant fill cap/dipstick.
- Tilt the pressure washer on its side as shown. Drain lubricant into approved container.
NOTE: Drain the lubricant while the engine is still warm but not hot. Warm lubricant will drain quickly and more completely.
- After the crankcase is completely drained, return the pressure washer to an upright position.
- Fill with lubricant following the instructions in Adding Lubricant To The Engine earlier in this manual.

NOTE: Consult hazardous waste management guidelines in your area for the proper way to dispose of used lubricant.

PUMP LUBRICATION

The pump on this product was lubricated with a sufficient amount of high grade lubricant for the life of the unit under normal operating conditions. Therefore, no further lubrication is required.

STORING THE PRESSURE WASHER

See figure 23.

Store the pressure washer with the petrol tank empty by either draining the tank or running the pressure washer until the petrol runs out. Allow 30 minutes of "cool down" time before storing the machine. Never place the unit in any position other than upright on its wheels.

Store in a dry, covered area where the weather can't damage it.

It is important to store this product in a frost-free area. Always empty water from all hoses, the pump, and the detergent bucket before storing.

NOTE: Use of a fuel stabilizer and pump saver will give you better performance and increase the life of the machine.

Discharge fuel:

Drain the fuel tank completely. Stored fuel can go stale in 30 days.

Engine lubricant:

Drain the lubricant and replace with fresh, clean lubricant.

Spark plug:

- Disconnect spark plug wire and remove the spark plug. Pour about a teaspoon of clean, air-cooled, four-cycle lubricant through the spark plug hole into the combustion chamber.
- Leaving the spark plug out, pull the starter cord two or three times to coat the inside of the cylinder wall.
- Inspect the spark plug and clean or replace, as necessary.
- Reinstall the spark plug, but leave the spark plug wire disconnected.

Air filter:

- Clean the air filter.

Hoses and pump:

Flush the injection hose with clean water for 1-2 minutes. Remove all hoses. Empty the pump by pulling on the recoil starter about 6 times. This should remove most of the liquid from the pump.

Handle:

- Pull the handle release knob out and lower the handle to the down position.

PREPARING FOR USE AFTER STORAGE

- Pull the starter grip with rope three or four times to clean lubricant from the combustion chamber.
- Remove spark plug from the cylinder. Wipe lubricant from the spark plug and return it to the cylinder.
- Reconnect the spark plug wire.
- Refuel the machine as described earlier in the operator's manual.

PERIODIC MAINTENANCE SCHEDULE



Maintenance Items	Each use	20 hours	50 hours
Check for leakage and loose parts	■		
Check and refill engine lubricant	■		
Change engine lubricant *		■	
Clean spark plug		■	
Clean air cleaner		■	
Replace air cleaner element			■
Clean fuel cap			■
Clean and adjust spark plug and electrodes			■
Replace spark plug			■
Remove carbon from cylinder head **			■
Check and adjust valve clearance **			■
Clean and adjust carburetor **			■
Check fuel lines			■

* Initial lubricant change should be performed after first twenty hours of operation. Thereafter change lubricant every fifty hours. Dispose of waste lubricant safely and responsibly. Do not pour into sewage drains, onto garden soil or into open streams. Your local zoning or environmental regulations will give you more detailed instructions on proper disposal.

** As to the procedures for these items, consult your nearest Subaru service dealer.

TROUBLESHOOTING

PROBLEM	CAUSE	POSSIBLE SOLUTION
Engine fails to start	<p>No fuel in tank</p> <p>Spark plug shorted or fouled</p> <p>Spark plug is broken (cracked porcelain or electrodes broken)</p> <p>Ignition lead wire shorted, broken, or disconnected from spark plug</p> <p>Ignition inoperative</p>	<p>Fill tank</p> <p>Replace spark plug</p> <p>Replace spark plug</p> <p>Replace lead wire or attach to spark plug</p> <p>Contact authorised service center</p>
Engine hard to start	<p>Water in gasoline</p> <p>Weak spark at spark plug</p>	<p>Drain entire system and refill with fresh fuel</p> <p>Contact authorised service center</p>
Engine lacks power	Dirty air filter	Clean or replace air filter
Detergent fails to mix with spray	<p>Detergent injection hose is not properly submerged</p> <p>Spray selector on the 5-in-1 Change Over Nozzle is set to either the [40°], [25°], or [0°] setting</p>	<p>Insert injection hose into detergent container or detergent bottle</p> <p>Rotate the spray selector on the 5-in-1 Change Over Nozzle to either the Soap Short Range or Soap Long Range setting</p>
Pump doesn't produce pressure	<p>Spray selector on the 5-in-1 Change Over Nozzle is set to either the Soap Short Range or Soap Long Range setting.</p> <p>Inadequate water supply</p> <p>Trigger handle or spray wand leaks</p> <p>Nozzle is clogged</p> <p>Pump is faulty</p> <p>Air in line</p>	<p>Rotate the spray selector on the 5-in-1 Change over Nozzle to either the [40°], [25°], or [0°] setting</p> <p>Provide adequate water flow</p> <p>Check connections and / or replace trigger handle or spray wand</p> <p>Clean nozzle</p> <p>Contact authorised service center</p> <p>Squeeze trigger on trigger handle to remove air from line</p>
Machine doesn't reach high pressure	<p>Diameter of garden hose is too small</p> <p>Water supply is restricted</p> <p>Not enough inlet water</p> <p>Spray selector on the 5-in-1 Change Over Nozzle is set to either the Soap Short Range or Soap Long Range setting.</p>	<p>Replace with 3/4 in. garden hose</p> <p>Check garden hose for kinks, leaks, and blockages</p> <p>Open water source full force</p> <p>Rotate the spray selector on the 5-in-1 Change Over Nozzle to either the [40°], [25°], or [0°] setting</p>



Techtronic Industries (Australia) Pty. Ltd.
Level 1, 660 Doncaster Road
Doncaster, VIC 3108, Australia

Techtronic Industries New Zealand Ltd.
18-26 Amelia Earhart Avenue
Mangere, Auckland 2022, New Zealand