



# **CEMENT MIXER**

- 370 WATT
- 4.4 CU.FT



# **INSTRUCTION MANUAL**

**⚠ WARNING:** Read all safety warnings and all instructions. Failure to follow the warnings and instructions may result in electric shock, fire and/or serious injury. Save all warnings and instructions for future reference.

## SPECIFICATIONS - MODEL NO. FBT-6300

<b>Input:</b>	230 – 240V ~ 50Hz
<b>Motor Size:</b>	370W
<b>Motor Speed:</b>	1440/min
<b>Drum Speed:</b>	23-26/min
<b>Gross Drum Volume:</b>	220 Litres (7.7 cu ft)
<b>Unmixed Dry Volume:</b>	170 Litres (6 cu ft)
<b>Mixed Wet Volume:</b>	125 Litres (4.4 cu ft)
<b>Drum Mouth:</b>	Ø470mm (18½")
<b>Weatherproof Rating:</b>	IP44
<b>Weight:</b>	63kg

## KNOW YOUR PRODUCT

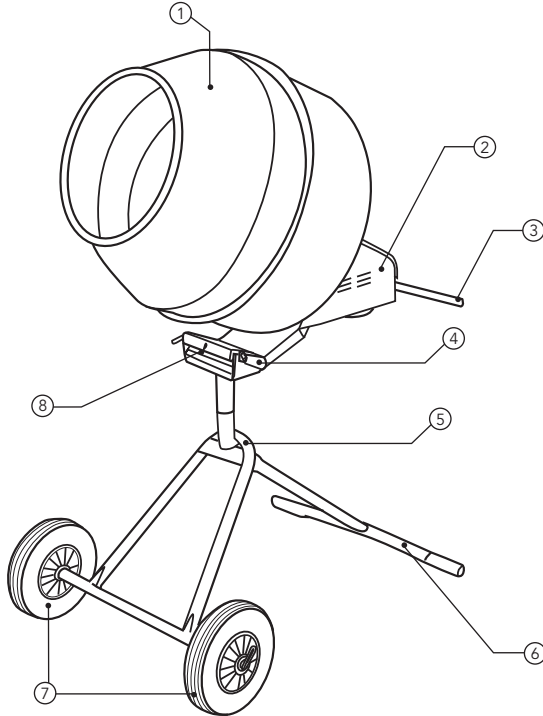

- |                        |                       |
|------------------------|-----------------------|
| 1. Drum                | 5. Frame              |
| 2. Motor Cover         | 6. Rear Leg           |
| 3. Dump Control Handle | 7. Pneumatic Wheel    |
| 4. Drum Lock Mechanism | 8. Drum Rotation Base |

## TABLE OF CONTENTS

SPECIFICATIONS.....	Page 2
KNOW YOUR PRODUCT.....	Page 2
INTRODUCTION.....	Page 4
SAFETY INSTRUCTIONS.....	Page 4
ASSEMBLY.....	Page 8
OPERATION .....	Page 9
MAINTENANCE .....	Page 10
CONTENTS .....	Page 11
WARRANTY.....	Page 12

## INTRODUCTION

Congratulations on purchasing a Full Boar Cement Mixer. Your Full Boar Cement Mixer FBT-6300 has been designed to mix cement, mortar, feeds, fertilizers, potting soils and the like.

## SAFETY INSTRUCTIONS



**Warning!** When using mains-powered equipment, basic safety precautions, including the following, should always be followed to reduce risk of fire, electric shock, personal injury and material damage.

Read and understand the manual prior to operating this tool.

Save these instructions and other documents supplied with this tool for future reference.

## ELECTRICAL SAFETY

The electric motor has been designed for 230V and 240V only. Always check that the power supply corresponds to the voltage on the rating plate.

**Note:** The supply of 230V and 240V on Full Boar tools are interchangeable for Australia and New Zealand.

If the supply cord is damaged, it must be replaced by an electrician or a power tool repairer in order to avoid a hazard.

### Using an Extension Lead

Always use an approved extension lead suitable for the power input of this tool. Before use, inspect the extension lead for signs of damage, wear and ageing. Replace the extension lead if damaged or defective.

When using an extension lead on a reel, always unwind the lead completely. Use of an extension lead not suitable for the power input of the tool or which is damaged or defective may result in a risk of fire and/or electric shock.

It is recommended that the extension lead is a maximum of 25m in length. Do Not use multiple extension leads.

# GENERAL SAFETY INSTRUCTIONS



**Warning!** Read all instructions. Failure to follow all instructions listed below may result in electric shock, fire and/or serious injury. The term "Power Tool" in all of the warnings listed below refers to your mains operated (corded) power tool or battery operated (cordless) power tool.

## SAVE THESE INSTRUCTIONS

### 1) WORK AREA

- a) **Keep work area clean and well lit.** Cluttered and dark areas invite accidents.
- b) **Do not operate power tools in explosive atmospheres, such as in the presence of flammable liquids, gases, or dust.** Power tools create sparks which may ignite the dust or fumes.
- c) **Keep children and bystanders away while operating a power tool.** Distractions can cause you to lose control.

### 2) ELECTRICAL SAFETY

- a) **Power tool plugs must match the outlet. Never modify the plug in any way. Do not use any adapter plugs with earthed (grounded) power tools.** Unmodified plugs and matching outlets will reduce risk of electric shock.
- b) **Avoid body contact with earthed or grounded surfaces such as pipes, radiators, ranges and refrigerators.** There is an increased risk of electric shock if your body is earthed or grounded.
- c) **Do not expose power tools to rain or wet conditions.** Water entering a power tool will increase the risk of electric shock.
- d) **Do not abuse the cord. Never use the cord for carrying, pulling or unplugging the power tool. Keep cord away from heat, oil, sharp edges or moving parts.** Damaged or entangled cords increase the risk of electric shock.
- e) **When operating a power tool outdoors, use an extension cord suitable for outdoor use.** Use of a cord suitable for outdoor use reduces the risk of electric shock.

### 3) PERSONAL SAFETY

- a) **Stay alert, watch what you are doing and use common sense when operating a power tool. Do not use a power tool while you are tired or under the influence of drugs, alcohol or medication.** A moment of inattention while operating power tools may result in serious personal injury.
- b) **Use safety equipment. Always wear eye protection.** Safety equipment such as dust mask, non-skid safety shoes, hard hat, or hearing protection used for appropriate conditions will reduce personal injuries.
- c) **Avoid accidental starting. Ensure the switch is in the off position before plugging in.** Carrying power tools with your finger on the switch or plugging in power tools that have the switch on invites accidents.
- d) **Remove any adjusting key or wrench before turning the power tool on.** A wrench or a key left attached to a rotating part of the power tool may result in personal injury.
- e) **Do not overreach. Keep proper footing and balance at all times.** This enables better control of the power tool in unexpected situations.

## GENERAL SAFETY INSTRUCTIONS (cont.)

- f) **Dress properly. Do not wear loose clothing or jewellery. Keep your hair, clothing and gloves away from moving parts.** Loose clothes, jewellery or long hair can be caught in moving parts.
- g) **If devices are provided for the connection of dust extraction and collection facilities, ensure these are connected and properly used.** Use of these devices can reduce dust related hazards.

### 4) POWER TOOL USE AND CARE

- a) **Do not force the power tool. Use the correct power tool for your application.** The correct power tool will do the job better and safer at the rate for which it was designed.
- b) **Do not use the power tool if the switch does not turn it on and off.** Any power tool that can not be controlled with the switch is dangerous and must be repaired.
- c) **Disconnect the plug from the power source before making any adjustments, changing accessories, or storing power tools.** Such preventive safety measures reduce the risk of starting the power tool accidentally.
- d) **Store idle power tools, unplugged & out of the reach of children and do not allow persons unfamiliar with the power tool or these instructions to operate the power tool.** Power tools are dangerous in the hands of untrained users.
- e) **Maintain power tools. Check for misalignment or binding of moving parts, breakage of parts and any other condition that may affect the power tools operation. If damaged, have the power tool repaired before use.** Many accidents are caused by poorly maintained power tools.
- f) **Keep cutting tools sharp and clean.** Properly maintained cutting tools with sharp cutting edges are less likely to bind and are easier to control.
- g) **Use the power tool, accessories and tool bits etc., in accordance with these instructions and in the manner intended for the particular type of power tool, taking into account the working conditions and the work to be performed.** Use of the power tool for operations different from intended could result in a hazardous situation.
- h) **This appliance is not intended for use by persons (including children) with reduced physical, sensory or mental capabilities, or lack of experience and knowledge,** unless they have been given supervision or instruction concerning use of the appliance by a person responsible for their safety.
- i) **Children should be supervised to ensure that they do not play with the appliance.**

### 5) SERVICE

- a) **Have your power tool serviced by a qualified repair person using only identical replacement parts.** This will ensure that the safety of the power tool is maintained.
- b) **If the supply cord is damaged,** it must be replaced by the manufacturer, its service agent or similarly qualified persons in order to avoid a hazard.

## ADDITIONAL SAFETY RULES FOR CEMENT MIXER



**Warning!** For your own safety, do not try to use your cement mixer or plug it in until it is completely assembled and installed according to the instructions and until you have read and understood the following:

- **Drugs, alcohol and medication.** Do not operate the mixer while under the influence of drugs, alcohol, or any medication that could affect your ability to use it properly.
- **Avoid dangerous conditions.** Keep your work area clean and well lit. Cluttered areas can cause accidents resulting in injuries. Do not use the mixer in wet or damp areas or expose it to rain. Do not use it in areas where fumes from paint, solvents or flammable liquids pose a potential hazard.
- **Inspect your cement mixer.** Check your cement mixer before turning it on. Keep guards in place and in working order. Form a habit of checking to see that keys and adjusting wrenches are removed from the cement mixer area before turning on. Replace damaged, missing or failed parts before using it.
- **Wear protective gear.** Foreign objects may be thrown from the cement mixer while in operation. This can cause facial injuries. Always wear safety goggles and/or face shields.
- **Loading the cement mixer.** Do not attempt to load or unload the contents until the cement mixer has stopped. Keep hands out of the way of all moving parts.
- **Never leave cement mixer running unattended.** Don't leave cement mixer until it has come to a complete stop.
- **Disconnect power.** Unplug when not in use, before making adjustments, changing parts, cleaning, or working on the mixer.
- **Maintain your cement mixer with care.** Clean the cement mixer immediately after use. Keep the cement mixer clean for best and safest performance.
- **Moving the cement mixer.** Do not tow the cement mixer by using a vehicle. Use an approved trailer to move the cement mixer if it is to be transported.

# ASSEMBLY

1. Insert the rear leg of the stand into the front frame using the nut and bolt supplied. Tighten the bolt. The rear leg is also used to move the mixer to other locations. (Fig. 1)

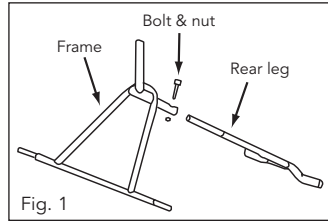

2. Slide the wheels onto the front frame axle and insert the cotter pin into the hole in the axle to hold the wheels in place. (Fig. 2) Check and maintain tyre pressure @ 206kPa (30psi)

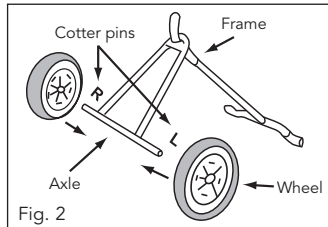

3. Attach the drum rotation base to the motor gear box assembly frame using the heavy duty anchor pin. After you connect the motor frame and rotation base with the anchor pin insert the cotter pin to hold the anchor pin in place. (Fig. 3)

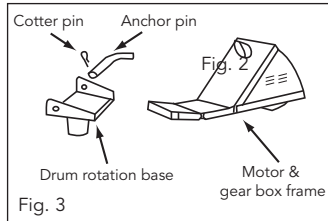

4. Slide the drum rotation base and motor frame assembly onto the shaft of the cement mixer frame. (Fig. 4)

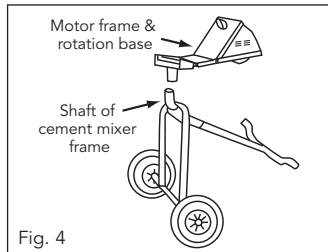

5. Mount the cement mixer drum onto the gear box shaft. Turn the drum clockwise on the gear box shaft thread until the shaft is completely located in the drum. (Fig. 5)

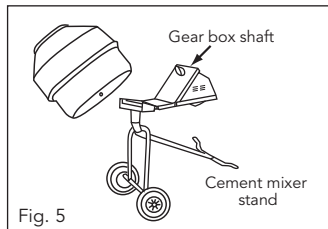



## ASSEMBLY (cont.)

6. Insert the dump control handle through the hole in the motor gear box frame. Locate 2 notches on the inside of the motor housing, align with the handle and push the handle to fit securely in the notches. Secure it with the cotter pin provided. (Fig. 6)

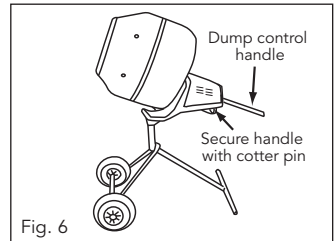

## OPERATION

### Loading the drum

**IMPORTANT:** Completely unwind an extension cord (not supplied). Connect it to the concrete mixer first before connecting to a power supply.

**IMPORTANT:** Always start the mixer before loading the drum. Load the drum while it's rotating.

**IMPORTANT:** Ensure material is not all loaded into the mixer at once. Add the material steadily over the mixing blades instead to avoid the material from sticking to the back of the drum.

**Note:** A built-in thermal protector has been built into the motor to prevent it from overheating. The thermal protector restores automatically when the motor cools down.

For best loading results, proceed as follows:

- Add the required amount of stone into the drum.
- Add the required amount of sand into the drum.
- Add the required amount of cement into the drum.
- Pour the required amount of water into the drum.

### Warnings:

1. Do not let the shovel mouth or any other devices enter the drum mouth during loading.
2. Never place hands inside the revolving drum.
3. Place the mixer as close as possible to the work site. Do not move the mixer when loaded. The front handle is only to be used to move the mixer when the drum is empty.
4. Re-tighten all bolts and nuts after mixing for the first time.

### Emptying the drum

**IMPORTANT:** Do not turn the mixer off while it's full of material. Empty the drum with the drum rotating.

Pour the mixed concrete by releasing the drum lock mechanism and lifting the dump control handle while the machine is running. Be sure to pour the mix slowly and smoothly to avoid tilting the concrete mixer.

## OPERATION (cont.)

### Cleaning

**Warning:** Do not pour or spray water directly into or over the motor cover.

**IMPORTANT:** Never put any of your body parts (including hands) inside the drum while it is rotating.

**IMPORTANT:** Wipe off any external material on the motor cover. Do not use petrol, turpentine, lacquer or paint thinner, dry cleaning fluids or similar products. The use of chemical products or solvents may damage the motor cover.

Thoroughly clean the mixer at the end of each days operation.

Keep your mixer clean. The slightest trace of material left in the drum will harden and attract more material each time the machine is used.

Dried cement should be scraped out of the drum.

DO NOT throw bricks into the mixer drum to clean it out.

DO NOT beat on the drum with a shovel, hammer or other tools to break up accumulation of dried cement mix as the cement mixer may be damaged.

The drum may be scoured for approximately 2 minutes, using a 1" (2.5cm) stone and water mixture. After this, discharge the stone/water mixture and hose down the drum assembly inside and out.



The IP55 protection clad construction of the mixer enables the DRUM ASSEMBLY ONLY to be hosed down safely. Avoid getting water on the motor housing, DO NOT wet the motor.

## MAINTENANCE

1. Ensure that the power is disconnected from the tool prior to any maintenance being carried out.
2. Ball bearings are packed with grease at the factory. No further lubrication of bearings is required.
3. Lubricate all moving parts periodically. Wipe and other parts with an oily cloth to keep corrosion to a minimum.
4. During normal use, painted surfaces can loose their coating during the mixing process. Wipe all exposed surfaces regularly with an oily rag to prevent corrosion. (Note: Rust is not a warrantable claim.)
5. Keep air vents clean of dust and dirt.
6. Remove dust and dirt from the cement mixer regularly with soft cloth, brush or compressed air. Use a mild detergent and a soft cloth to clean plastic parts.
7. If the power cord is damaged, have it replaced by an electrician or a power tool repairer.
8. Regularly check that all bolts, screws and nuts are securely fixed as these could work loose during normal operation.
9. Check and maintain tyre pressure @ 206kPa (30psi)

**Note:** Full Boar will not be responsible for any damage or injuries caused by the repair of the tool by an unauthorised person or by mishandling of the tool.

## DESCRIPTION OF SYMBOLS

<b>V</b>	Volts	<b>Hz</b>	Hertz
~	Alternating current	<b>W</b>	Watts
<b>/min</b>	Revolutions or reciprocation per minute	<b>No</b>	No load speed
<b>Hp</b>	Horse power		Regulator compliance mark
∅	Diameter	<b>cu ft</b>	Cubic Foot
<b>kPa</b>	Kilo Pascals	<b>psi</b>	Pounds per square inch
	Use eye protection		Warning

## CARING FOR THE ENVIRONMENT



Power tools that are no longer usable should not be disposed of with household waste but in an environmentally friendly way. Please recycle where facilities exist. Check with your local council authority for recycling advice.



Recycling packaging reduces the need for landfill and raw materials. Reuse of recycled material decreases pollution in the environment. Please recycle packaging where facilities exist. Check with your local council authority for recycling advice.

## CONTENTS

- 1 x FBT-6300 Cement Mixer (not assembled; see Page 8 of instruction manual)
- 1 x Instruction Manual

Distributed by:  
Ozito Industries Pty Ltd

### AUSTRALIA (Head Office)

1-23 Letcon Drive, Bangholme Victoria, Australia, 3175  
Telephone: 1800 069 486

# WARRANTY

**YOUR WARRANTY FORM SHOULD BE RETAINED BY YOU AT ALL TIMES. IN ORDER TO MAKE A CLAIM UNDER THIS WARRANTY YOU MUST RETURN THE PRODUCT TO YOUR NEAREST BUNNINGS WAREHOUSE (see [www.bunnings.com.au](http://www.bunnings.com.au) or [www.bunnings.co.nz](http://www.bunnings.co.nz) for store locations) WITH YOUR BUNNINGS REGISTER RECEIPT. PRIOR TO RETURNING YOUR PRODUCT FOR WARRANTY PLEASE TELEPHONE OUR CUSTOMER SERVICE HELPLINE:**

**Australia 1800 069 486  
New Zealand 0508 069 486**

TO ENSURE A SPEEDY RESPONSE PLEASE HAVE THE MODEL NUMBER AND DATE OF PURCHASE AVAILABLE. A CUSTOMER SERVICE REPRESENTATIVE WILL TAKE YOUR CALL AND ANSWER ANY QUESTIONS YOU MAY HAVE RELATING TO THE WARRANTY POLICY OR PROCEDURE.

## 1 YEAR WARRANTY

Your product is guaranteed for a period of **12 months from the original date of purchase**. If a product is defective it will be repaired in accordance with the terms of this warranty. Warranty excludes consumable parts, for example: wheels, bearings.

The benefits provided under this warranty are in addition to other rights and remedies which are available to you under law. The warranty covers manufacturer defects in materials, workmanship and finish under normal use.

Our goods come with guarantees that cannot be excluded under Australian Consumer law & Consumer Guarantees Act 1993 (NZ). You are entitled to a replacement or refund for a major failure and to compensation for other reasonably foreseeable loss or damage. You are also entitled to have the goods repaired and replaced if the goods fail to be of acceptable quality and the failure does not amount to a major failure.

## WARRANTY EXCLUSIONS

**The following actions will result in the warranty being void.**

- If the tool has been operated on a supply voltage other than that specified on the tool.
- If the tool shows signs of damage or defects caused by or resulting from abuse, accidents or alterations.
- Failure to perform maintenance as set out within the instruction manual.
- If the tool is disassembled or tampered with in any way.
- The warranty excludes damage resulting from product misuse or product neglect.

**This warranty is given by Ozito Industries Pty Ltd.**

**ABN: 17 050 731 756**

**Ph.1800 069 486**

Australia/New Zealand (Head Office)

1-23 Letcon Drive, Bangholme, Victoria, Australia 3175