

BOSE6511X

60cm, 5 function, Built In Electric Oven

BLANCO



Model Code

BOSE6511X

Description

60cm, 5 Function, Electric Oven

Included Accessories

- 1 x telescopic runner
- 2 x safety anti-tip shelves
- 1 x enamelled baking tray
- 1 x grill pan insert

Made In Italy

Designed and Manufactured in Italy

Warranty

4 year warranty

Features

Large oven capacity

Thermo-reflective Door

60 minute minder

Black Enamelled Cavity

Easy Installation

Benefits

At 72 litres, this larger capacity oven will accommodate even the biggest meals.

The thermo-reflective glass offers not only a cooler to touch surface but also increases the energy efficiency as the heat is retained within the oven.

The useful and easy to use minute minder will alert you when the selected cooking has elapsed.

Hard wearing enamel cavity that is easy to clean.

Easy plug in installation, no electrician required.

Specifications

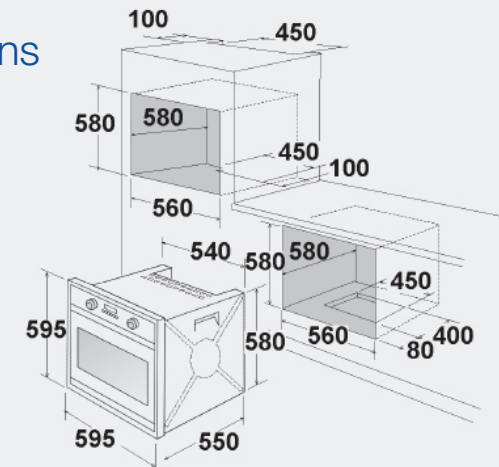

Product Dimensions:	H595 x W595 x D550mm
Cut-out size (proudmount):	H580 x W560 x D580mm
Cut-out size (flushmount):	H598 x W598 x D580mm
Power Requirement:	220-240V – 50Hz
Electrical connection:	10 amp- 3 pin plug supplied
Oven volume:	72 litre capacity
Oven Functions:	Fan Forced, Full Grill, Fan Grill, Defrost, Light
Lighting:	25 W

Oven Elements:

Fan forced element:	2300 W
Hot air fan motor:	20-25 W
Cooling fan motor:	25 W

NOTE: It is advisable to check dimensions of physical product when measuring for installation and before doing any cut outs.

*Due to continual product development the information provided is not final and may be subject to change.