



# MULTISTORE

## ASSEMBLY INSTRUCTION FOR MAXI ULTRA 450



**MAXI ULTRA 450**

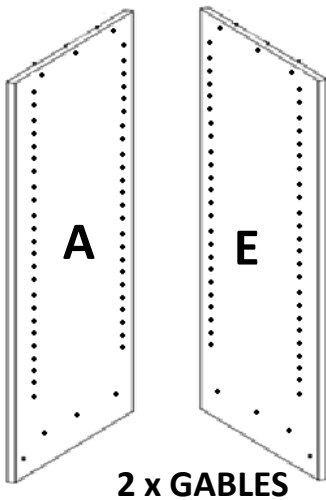

**2 x GABLES**

1 x BOTTOM KICK



2 x FIXED SHELVES

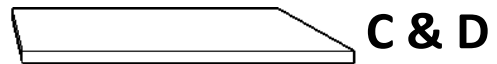



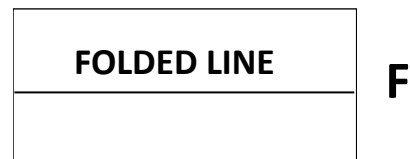



1 x FOLDED BACK



**FOLDED LINE**

**F**

NO	MODEL	DESCRIPTION	QTY	NO	MODEL	DESCRIPTION	QTY
1		50mm x 5mm CONFIRMAT SCREWS	10	4		16mm PAN HEAD SCREW	1
2		WHITE CAPS	10	5		25mm PAN HEAD SCREW	1
3		BACKING NAILS	30	6		"L" SAFETY BRACKET	1



# MULTISTORE

## ASSEMBLY INSTRUCTION FOR MAXI ULTRA 450

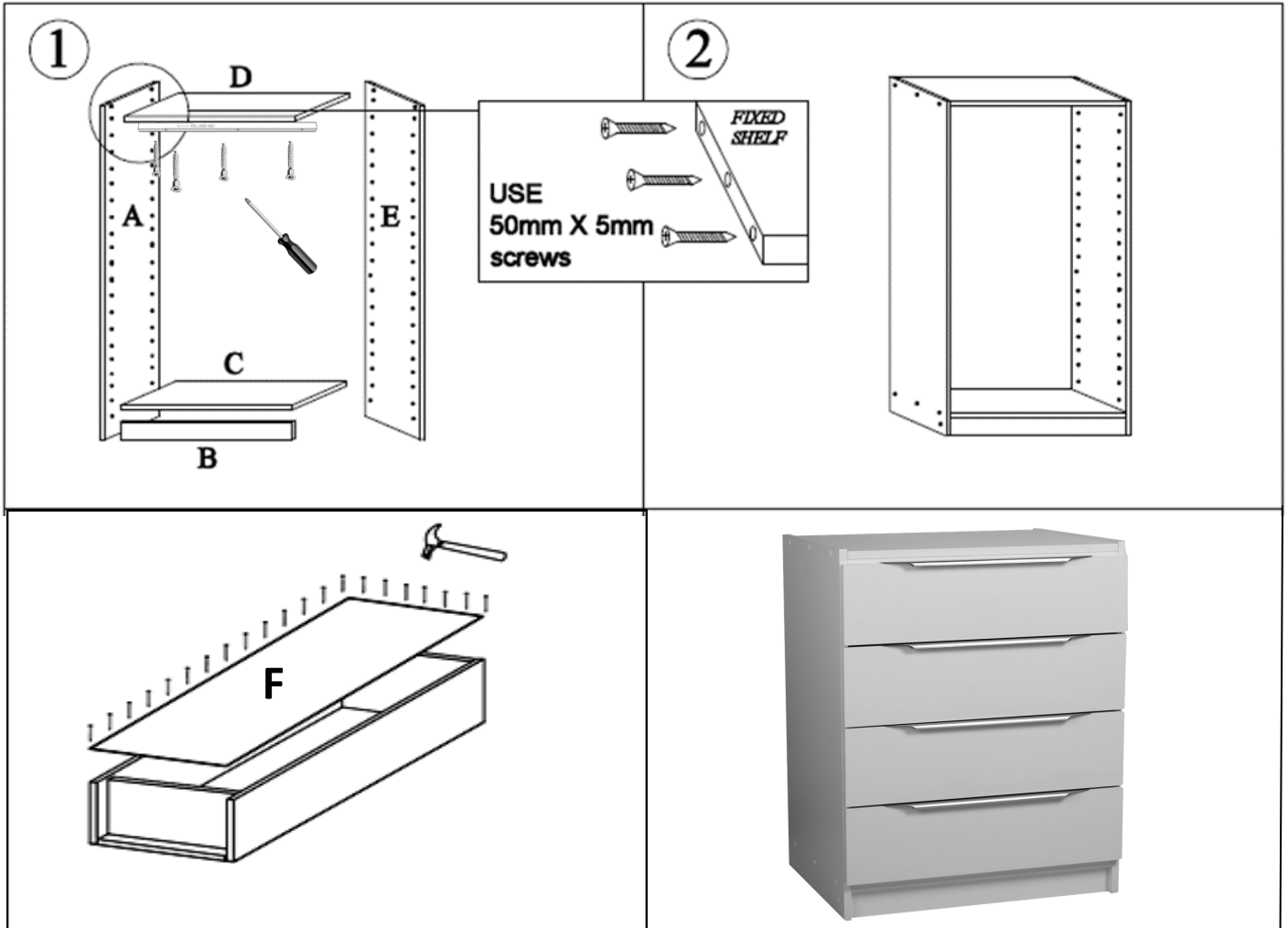

	<b>WARNING:</b> Serious injury or death can be caused by toppling furniture
<b>Help prevent tip-over:</b>	
<ul style="list-style-type: none"><li>Anchor this product to a wall or other suitable surface</li><li>Check anchors regularly</li></ul>	<ul style="list-style-type: none"><li>Avoid placing TVs on top unless the TV is also anchored</li><li>Use drawer locks to prevent children climbing</li></ul>

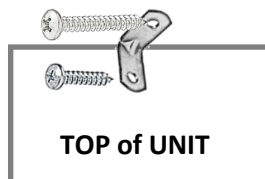

When attaching unit to wall put safety bracket in middle of unit with 16mm pan head screw then 25mm pan head screw into wall. For plaster-board without a stud it is recommended to use a plug with screw (not provided).



---

## **WARRANTY**

---

Our goods come with guarantees that cannot be excluded under the Australian Consumer Law. You are entitled to a replacement or refund for major failure.

### 10 Year Warranty

- If the purchaser has a fault or defect with this product, the purchaser needs to contact Multistore Industries (Aust) directly on (07) 3208 6799 and state date of purchase, place of purchase and proof of purchase.
- Multistore Industries (Aust) will replace any faulty or defect parts at no cost to the customer. A replacement will be sent to you as soon as possible, or product can be exchanged at the store of purchase.
- This warranty is in addition to other rights and remedies of the customer under law.

Sincerely,

Multistore Industries (Aust) Management