

HEATSTRIP® 

HEATSTRIP® 

GAS HEATING PRODUCT MANUAL

INTRODUCING THE HEATSTRIP GAS RANGE



CONTENTS

INTRODUCTION	2
.....
CONTENTS	3
.....
WALL MOUNTED NATURAL GAS HEATER (TGH34WN)	4
.....
SPECIFICATIONS, ACCESSORIES, HEATING AREAS	5
.....
CLEARANCES & DIMENSIONS, OPTIONAL ACCESSORIES	6
.....
PORTABLE LPG OUTDOOR HEATER (TGH34PL)	7
.....
SPECIFICATIONS, ACCESSORIES, HEATING AREAS	8
.....
CLEARANCES & DIMENSIONS, OPTIONAL ACCESSORIES	9
.....
CONTACT PAGE	10
.....

HEATSTRIP is a world leader in the design and manufacture of electric and gas heaters, designed both for outdoor and indoor applications.

The range of electric radiant strip heaters (Heatstrip Classic & Elegance models) are fully designed, engineered and assembled in Australia, and exported to the world. Industry recognition of Heatstrip quality includes the “Australian Business Award” for Product Value (Heatstrip Classic), as well as the “Victorian Manufacturer of the Year” and induction into the “Manufacturing Hall of Fame” by the Victorian State Government.

Heatstrip is proud to introduce a new range of gas heaters, which includes both portable LPG and wall mounted Natural Gas units. The TGH34PL Portable LPG heater was recently awarded a Good Design Selection for product design and quality.



The new HEATSTRIP Wall Mounted Natural Gas (NG) heater is a stylish addition to any outdoor area, where mains Natural Gas is preferred. World class design aesthetics, heat output and performance, for both residential and commercial applications.

FEATURES

- 34MJ, 4 tile commercial quality ceramic burner, for connection to mains Natural Gas (NG)
- Electronic battery ignition with micro-switch On/Off operation and stainless steel pull cords. Electrical connection not required
- Protective grille and reflector included as standard, to guarantee safe operation. Reflector design ensures that only a minimum of 500mm overhead clearance is required. A low clearance (300mm) HeatShield is also available (TGHAC-003)
- Wall mounting bracket allows for multiple mounting angles, and is extremely robust to provide strength and support
- An LPG version is also available (Model TGH34WLPG)
- 2 year residential and 1 year commercial warranty



HEATSTRIP® Wall Mounted
Natural Gas Heater (TGH34WN)

SPECIFICATIONS - WALL MOUNTED NATURAL GAS HEATER

MODEL NUMBER	TGH34WN
NUMBER OF TILES	4 CERAMIC TILES
IGNITION	Electronic Battery (AA battery)
DIMENSIONS	650mm (width) x 190mm (depth) x 380mm (height)
HOSE CONNECTION	5/8"-18UNF (3/8"SAE) (Includes 300mm hose and NG regulator)
RUNNING COST	\$0.68/hr (based on a 2¢/MJ)
WEIGHT	11.5 kg
HEATING AREA	16 sqm ² (4m x 4m)
GAS TYPE	Natural Gas (AGA approved No. 8442G)
GAS PRESSURE	1.00 KPA
GAS CONSUMPTION	34 MJ/Hr
INJECTOR SIZE	1.40mm* 4
MATERIALS OF CONSTRUCTION	E-coated mild steel with powder coat finish. Grille & reflector with extra high temperature protection.

Wall mounted LPG model TGH34WLPG injector size: 0.83mm 4, Gas pressure 2.75 KPA

FEATURES



Adjustable wall mounting bracket



4 tile commercial ceramic burner



ON / OFF switch with electronic ignition

HEATING AREA PROFILE

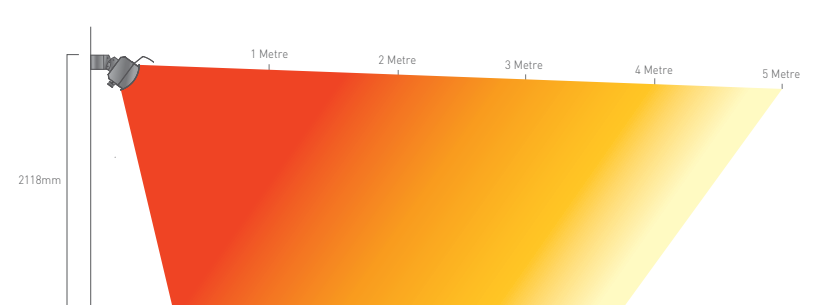
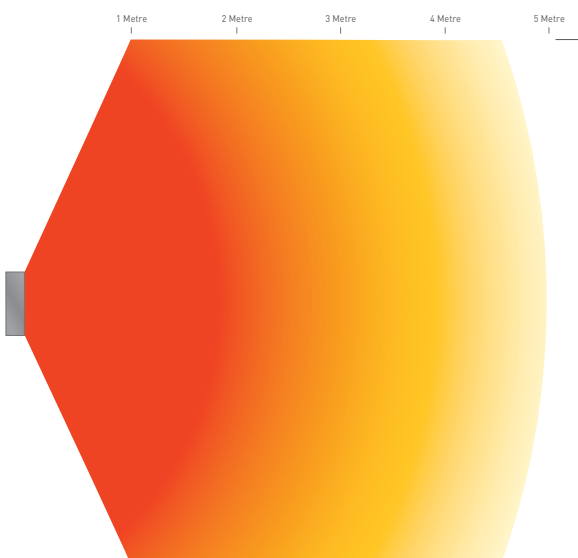

Note:

This appliance is for outdoor and non-residential indoor use only.

This appliance must not be installed or used in residential indoor areas only.

For non-residential indoor use, a minimum volume of 175m³ is required per heater.

Please refer to the installation manual for correct outdoor installation locations.

CLEARANCES AND DIMENSIONS

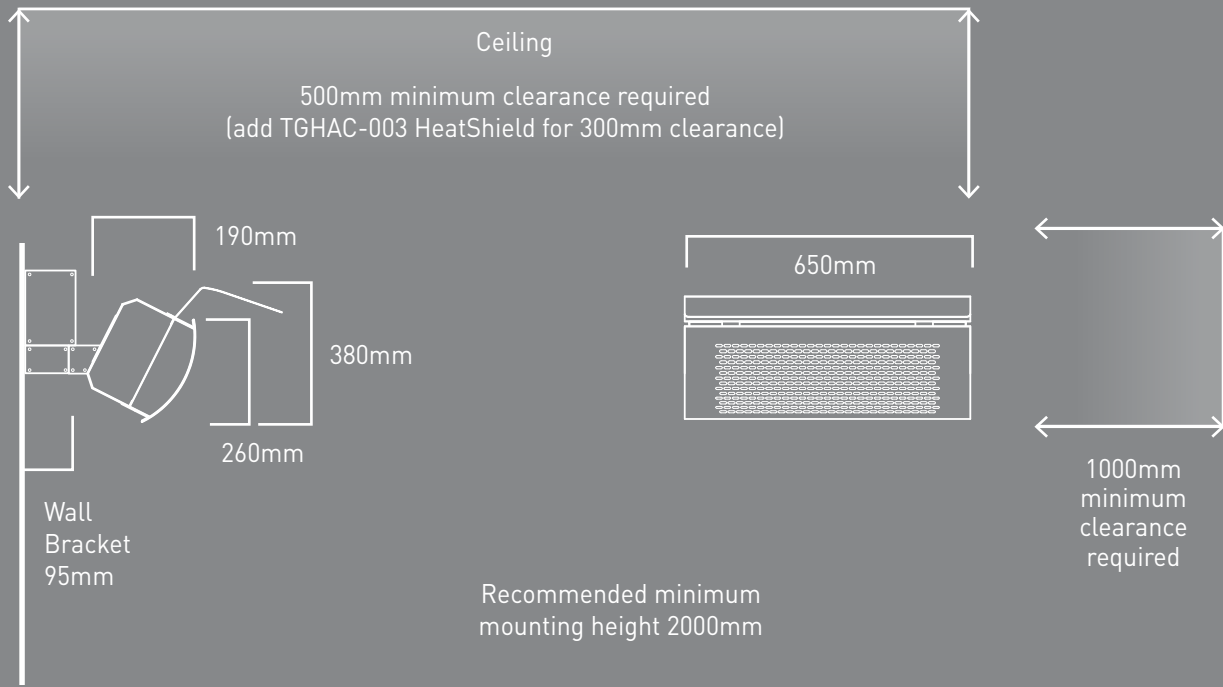

Note: Not suitable for open and exposed locations subject to rain.

OPTIONAL ACCESSORIES

Protective Heat Shield (TGHAC-003).

Allows for low clearance installations - 300mm from HeatShield to ceiling.



Ceiling pole extension (TGHAC-004).

Allows heater to be suspended from a ceiling.

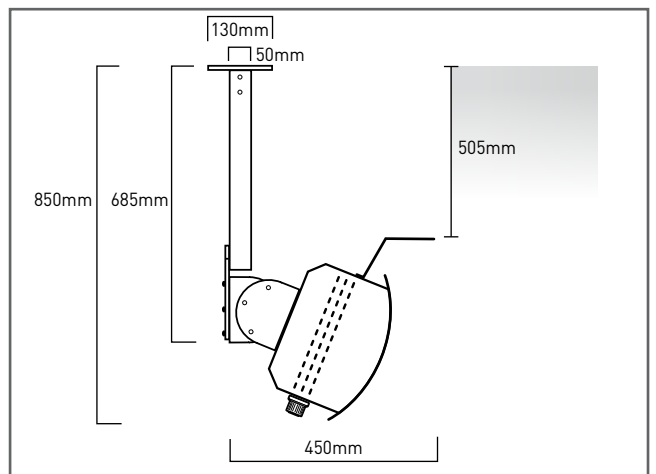
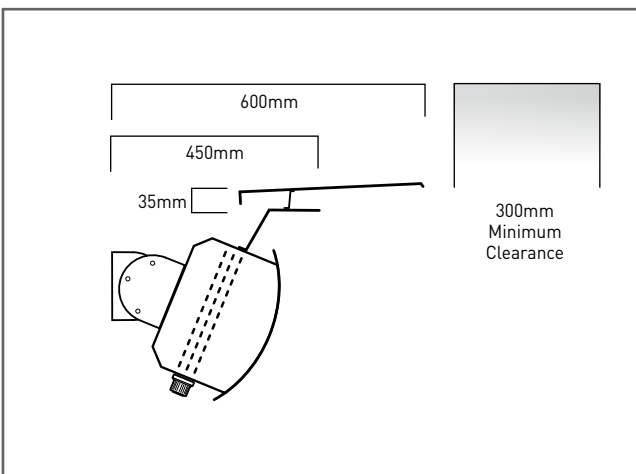

HEATSTRIP® Portable LPG Outdoor Heater (TGH34PL)



The new HEATSTRIP portable LPG heater incorporates world leading design, quality, heat performance and efficiency to provide a stylish, robust and elegant solution for your outdoor area, alfresco, balcony, patio etc.

FEATURES

- 34 MJ, 4 tile commercial quality ceramic burner
To be used with 9kg LPG bottle (not included)
- Manual integrated Piezo ignition, with tilt safety switch and flame failure device. Fully concealed gas pipes and bottle
- In-built wheels for easy portability and storage
- Components are sub-assembled for easy DIY installation
- High/Low heating output. Directional heat performance allows you to heat exactly where you want it
- Protective grille and reflector included as standard, to guarantee safe operation. Reflector design ensures that only a minimum of 500mm overhead clearance is required
- 2 year residential and 1 year commercial warranty



HEATSTRIP® Portable LPG (TGH34PL)



Optional heater cover available (TGHCOVER)

SPECIFICATIONS - PORTABLE LPG HEATER

MODEL NUMBER	TGH34PL
NUMBER OF TILES	4 CERAMIC TILES
IGNITION TYPE	Manual, Piezo
DIMENSIONS	650mm (width) x 670mm (depth) x 2118mm (height)
HOSE CONNECTION	5/8" -18UNF (3/8"SAE)
RUNNING COST	\$1.60 on high - \$1.12 on low. Based on \$20 per gas bottle refill, run time of 12.5hrs on high / 18 hrs on low
WEIGHT	31.5 kg
HEATING AREA	16 sqm ² (4m x 4m)
GAS TYPE	Propane
TEST POINT PRESSURE	2.75 KPA
GAS CONSUMPTION	34 MJ/Hr
INJECTOR SIZE	0.83mm* 4
MATERIALS OF CONSTRUCTION	E-coated mild steel with powder coat finish. Grille & reflector with extra high temperature protection.

FEATURES



Heating output control (High/Low) with Piezo ignition



Concealed LPG bottle and connections



4 tile commercial ceramic burner



Built-in wheels and feet

HEATING AREA PROFILE

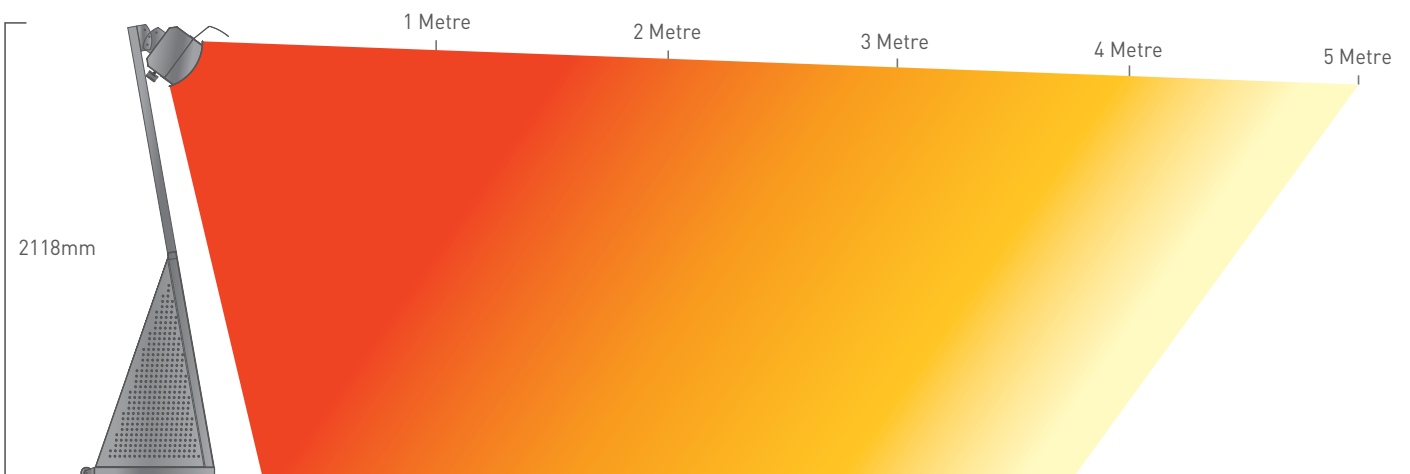

CLEARANCES AND DIMENSIONS

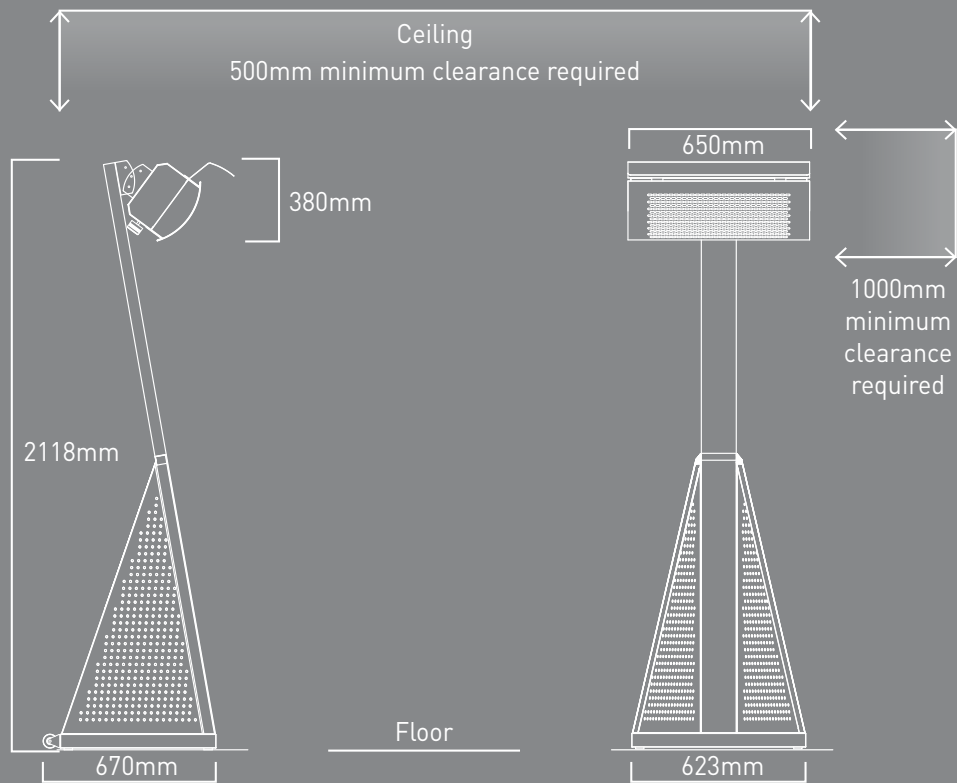

OPTIONAL ACCESSORIES - GAS BOTTLE CONVERSION KIT

The HEATSTRIP Portable LPG heater (TGH34PL) has been designed for a 9kg LPG bottle as standard. However the design can also accommodate a wide range of commercial and industrial grade LPG bottles that can extend the operating hours of the heater. Suitable sizes that the heater can accommodate are up to 45kg with the addition of a conversion kit.



BOTTLE SIZE	9 kg Gas Bottle	13.5 kg Gas Bottle	18 kg Gas Bottle	45 kg Gas Bottle
Conversion Kit P/N	N/A	N/A	TGHAC-001	TGHAC-002
Description	N/A	N/A	18kg gas bottle Conversion Kit	45kg gas bottle Conversion Kit
Kit Inclusions	N/A as all components are suitable for a standard 9kg bottle	To fit gas bottle, back cover must be removed permanently. No additional parts are required	Custom rear top panel & chain	Custom rear top panel, post back panel & chain

HEATSTRIP[®]

OUTDOOR HEATERS



Thermofilm Australia Pty Ltd
17 Johnston Court, Dandenong South, Victoria 3175, Australia.
p: (03) 9562 3455 | f: (03) 9548 3979 | e: sales@thermofilm.com.au
www.facebook.com/ThermofilmAustralia

heatstrip.com.au