

# RYOBI®

## RA-NC1565-K

### AIRWAVE AIR COIL NAILER OPERATOR'S MANUAL ORIGINAL INSTRUCTIONS

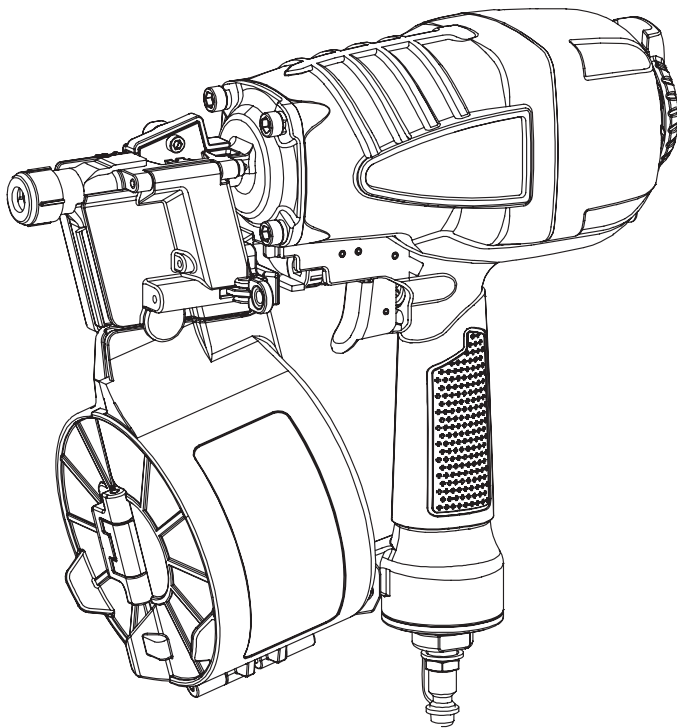

***Important!***

It is essential you read the instructions in this manual before starting and operating this machine.  
Subject to technical modifications.



## DESCRIPTION

- |   |   |   |
|---|---|---|
| <ul style="list-style-type: none"> <li>1. Nitto style coupler</li> <li>2. Exhaust cap</li> <li>3. Air supply</li> <li>4. Feeder cover</li> <li>5. Feeder cover latch</li> <li>6. Magazine cover</li> <li>7. Nails</li> <li>8. Spool</li> <li>9. Trigger</li> <li>10. Depth adjustment knob</li> <li>11. Rod (not included)</li> </ul> | <ul style="list-style-type: none"> <li>12. Hammer (not included)</li> <li>13. Flat blade screwdriver (not included)</li> <li>14. Jammed fastener</li> <li>15. Screw hole</li> <li>16. Rubber cap</li> <li>17. M8 screw hanger</li> <li>18. Safety yoke</li> <li>19. First nail</li> <li>20. Second nail</li> <li>21. Guide</li> </ul> | <ul style="list-style-type: none"> <li>22. Nail head track</li> </ul> |
|---|---|---|

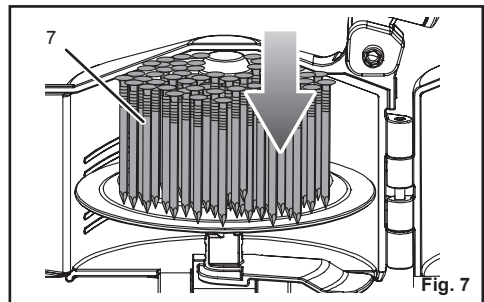
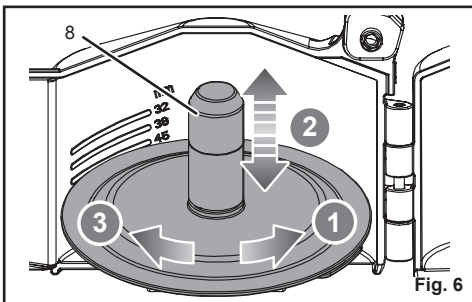
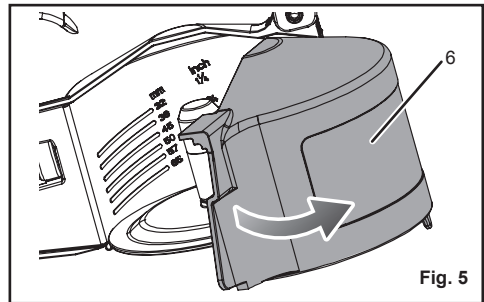
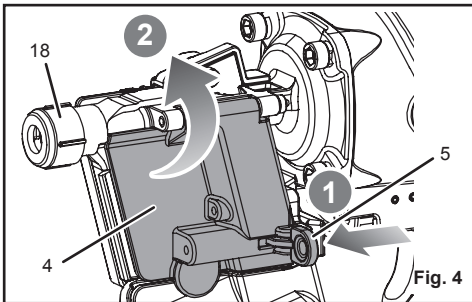
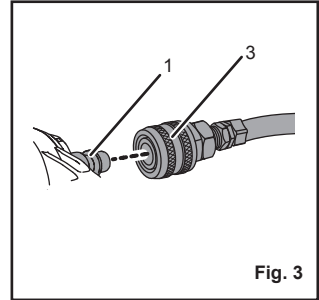
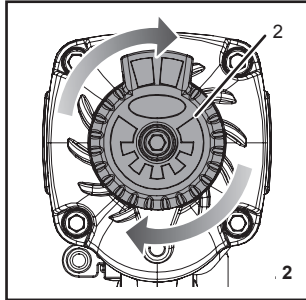
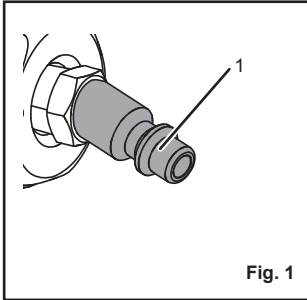

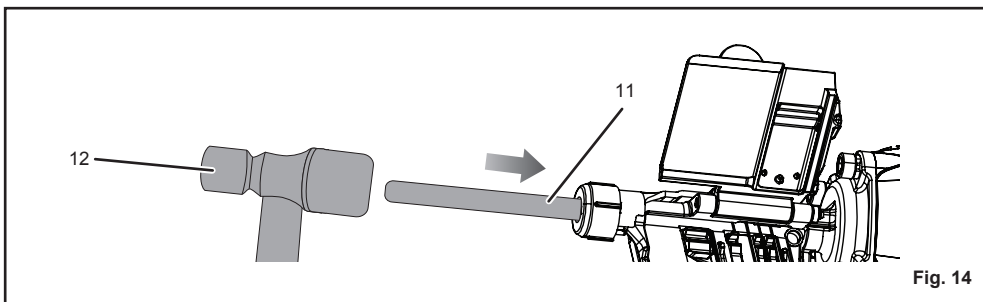
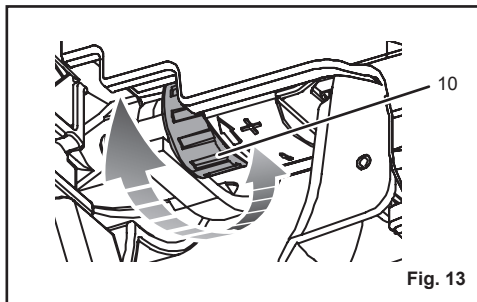
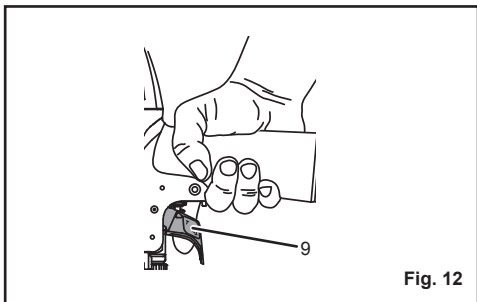
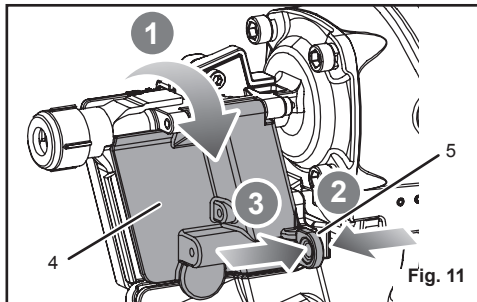
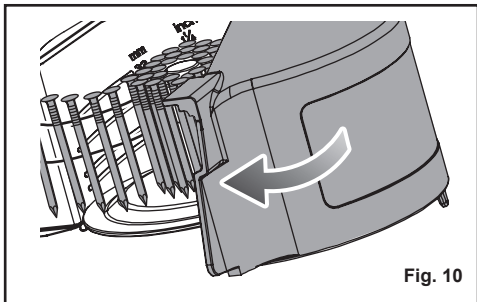
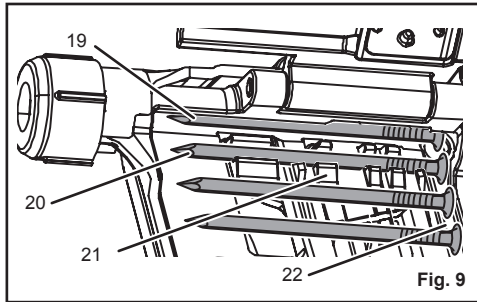
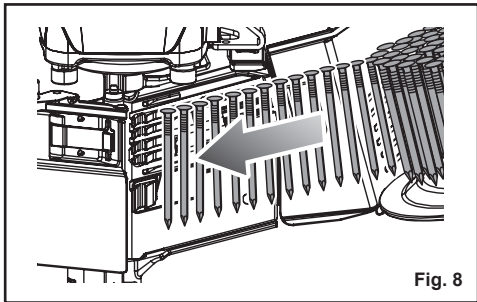

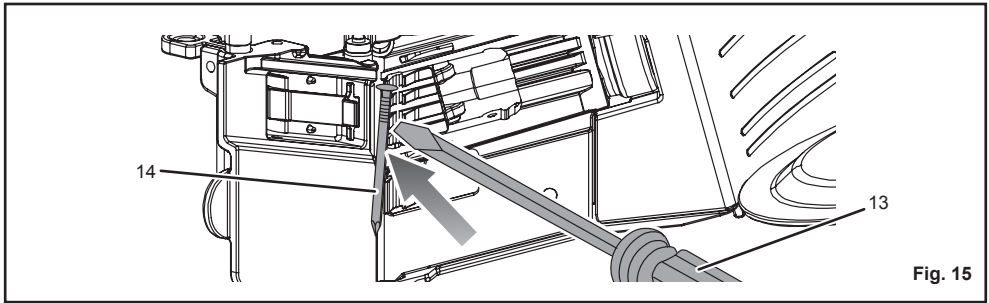

Fig. 15

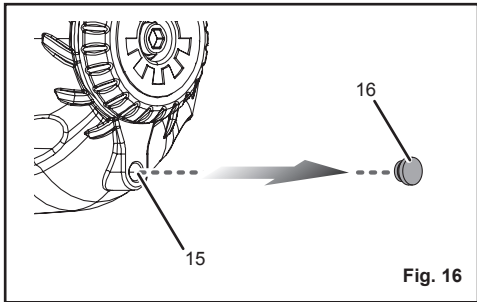

Fig. 16

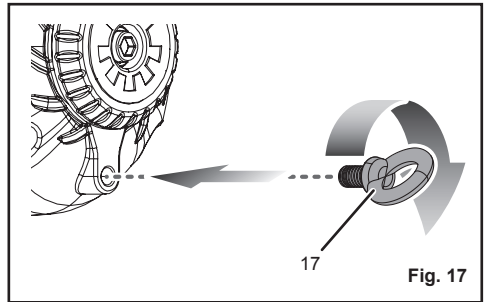

Fig. 17

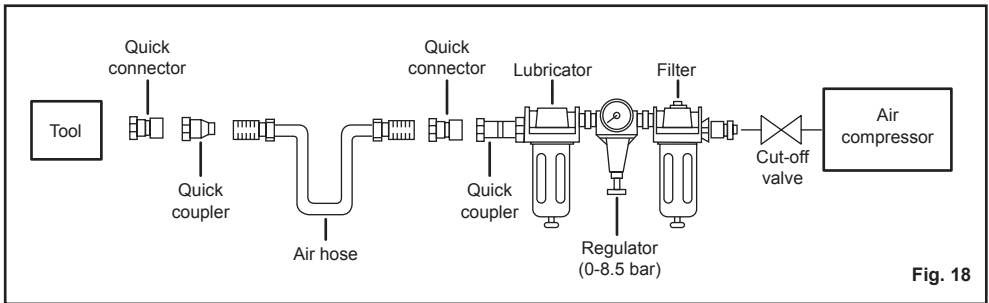

Fig. 18

## GENERAL SAFETY RULES

- For multiple hazards, read and understand the safety instructions before installing, operating, repairing, maintaining, changing accessories on, or working near, the air tool. Failure to do so can result in serious bodily injury.
- Only qualified and trained operators should install, adjust or use the air tool.
- Do not modify this air tool. Modifications can reduce the effectiveness of safety measures and increase the risks to the operator.
- Do not discard the safety instructions; give them to the operator.
- Do not use the air tool if it has been damaged.
- Tools shall be inspected periodically to verify that the ratings and markings required by this part of EN 792-13 are legibly marked on the tool. The employer/user shall contact the manufacturer to obtain replacement marking labels when necessary.

## PROJECTILE HAZARDS

- Be aware that the failure of the work piece, or accessories, or even of the fastener driving tool itself, can generate high-velocity projectiles.
- Always wear impact-resistant eye protection during the operation of the air tool. The grade of protection required should be assessed for each use.
- Ensure that the work piece is securely fixed.

## ENTANGLEMENT HAZARDS

Choking, scalping and/or lacerations can occur if loose clothing, personal jewellery, neck wear, hair or gloves are not kept away from the tool and accessories.

## OPERATING HAZARDS

- Operators and maintenance personnel shall be physically able to handle the bulk, weight and power of the tool.
- Hold the tool correctly; be ready to counteract normal or sudden movements and have both hands available.
- Maintain a balanced body position and secure footing.
- Release the start-and-stop device in the case of an interruption of the compressed air supply.
- Use only lubricants recommended by the manufacturer.
- Personal protective safety glasses shall be used; suitable gloves and protective clothing are recommended.

## REPETITIVE MOTIONS HAZARDS

- When using an air tool to perform work-related activities, the operator can experience discomfort in the hands, arms, shoulders, neck or other parts of the body.

- While using an air tool, the operator should adopt a comfortable posture while maintaining a secure footing and avoiding awkward or off-balanced postures. The operator should change posture during extended tasks, which can help avoid discomfort and fatigue.
- If the operator experiences symptoms, such as persistent or recurring discomfort, pain, throbbing, aching, tingling, numbness, burning sensations or stiffness, these warning signs should not be ignored. The operator should tell the employer and consult a qualified health professional.

## ACCESSORY HAZARDS

- Disconnect the air tool from the compressed air line before fitting or changing the fasteners or accessory.
- Use only sizes and types of accessories and consumables that are recommended by the air tool manufacturer; do not use other types or sizes of accessories and consumables.

## WORKPLACE HAZARDS

- Slips, trips and falls are major causes of workplace injury. Be aware of slippery surfaces caused by the use of the tool and also of trip hazards caused by the air line.
- Proceed with care in unfamiliar surroundings. There can be hidden hazards, such as electricity or other utility lines.
- The air tool is not intended for use in potentially explosive atmospheres and is not insulated against coming into contact with electric power.
- Ensure that there are no electrical cables, gas pipes, etc., that can cause a hazard if damaged by use of the tool.

## NOISE EMISSION

The characteristic noise values for the fastener driving tool have been determined in accordance with EN12549:1999 and EN ISO4871 "Acoustics-Noise test code for fastener driving tools-Engineering method" (see Specifications).

These values are tool-related characteristic values and do not represent the noise development at the point of use. Noise development at the point of use will for example depend on the working environment, the work piece, the work piece support, the number of driving operations, etc. Depending in the conditions at the workplace and the form of the workplace, individual noise attenuation measures may need to be carried out, such as placing work pieces on sound-damping supports, preventing work piece vibration by means of clamping or covering, adjusting to the minimum air pressure required for the operation involved, etc.

In special cases it is necessary to wear hearing protection equipment.



## INFORMATION ON MECHANICAL IMPACT(VIBRATION)

The characteristic vibration values for the fastener driving tool have been determined in accordance with ISO 8662-11:1999 and EN 12096 – Measurement of vibration in hand-held power tools – Part 11: Fastener driving tools (see Specifications).

This value is a tool-related characteristic value and does not represent the influence to the hand-arm-system when using the tool. An influence to the hand-arm-system when using the tool will for example depend on the gripping force, the contact pressure force, the working direction, the adjustment of compressed air supply, the workplace and the work piece support.

## ADDITIONAL SAFETY INSTRUCTIONS FOR PNEUMATIC POWER TOOLS

- Air under pressure can cause severe injury.
- Always shut off air supply, drain hose of air pressure and disconnect tool from air supply whenever not in use, before changing accessories or where making repairs.
- Never direct air at yourself or anyone else.
- Whipping hoses can cause severe injury. Always check for damaged or loose hoses and fittings.
- Cold air should be directed away from the hands.
- Whenever universal twist couplings (claw couplings) are used, lock pins shall be installed and whip check safety cables shall be used to safeguard against possible hose-to-tool and hose-to-hose connection failure.
- Do not exceed the maximum air pressure stated on the tool.
- Never carry an air tool by the hose.
- Only fasteners listed in the specifications may be used in the fastener driving tool. The fastener driving tool and the fasteners specified in the specifications are to be considered as one unit safety system.
- Quick action couplings shall be used for connection to the compressed air system and the non-sealable nipple must be fitted at the tool in such a way that no compressed air remains in the tool after disconnection.
- Oxygen or combustible gases shall not be used as an energy source for compressed air operated fastener driving tools.
- Fastener driving tools shall only be connected to an air supply where the maximum allowable pressure of the tool cannot be exceeded by more than 10%; in the case of higher pressure ,a pressure reducing valve which includes a downstream safety valve shall be built into the compressed air supply.
- Only the main energy and the lubricants listed in the operating instructions may be used for the maintenance of fastener driving tools. Only spare parts specified by the manufacturer or his authorised representative shall be used.

- Repairs shall be carried out only by the manufacturer's authorized agents or by other experts, having due regard to the information given in the operating instructions.
- Stands for mounting the fastener driving tools to a support, for example to a work table, shall be designed and constructed by the stand manufacturer in such a way that the fastener driving tools can be safely fixed for the intended use, thus for example avoiding damage, distortion and displacement.
- Check prior to each operation that the safety and triggering mechanism is functioning properly and that all nuts and bolts are right.
- Do not carry out any alterations to the fastener driving tool.
- Do not disassemble or make inoperative any parts of the fastener driving tool such as the safety yoke.
- Do not perform any "emergency repairs" without proper tools and equipment.
- The fastener driving tool should be serviced properly and at regular intervals in accordance with the manufacturer's instructions.
- Avoid weakening or damaging the tool, for example by:
  - punching or engraving;
  - modification not authorized by the manufacturer;
  - guiding against templates made of hard material such as steel;
  - dropping or pushing across the floor;
  - using the tool as a hammer;
  - applying excessive force of any kind.
- Never point any fastener driving tool at yourself or at any other person or animal.
- Hold the fastener driving tool during the work operation in such a way that no injuries can be caused to the head or to the body in the event of possible recoil consequent upon a disruption in the compressed air supply or hard areas within the workplace.
- Never actuate the fastener driving tool into free space. This will avoid any hazard caused by free flying fasteners and excessive strain of the tool.
- The tool shall be disconnected from the compressed air system for the purpose of transportation, especially where ladders are used or where an unusual physical posture is adopted whilst moving .
- Carry the fastener driving tool at the workplace using only the handle, and never with the trigger actuated.
- Take conditions at the workplace into account. Fasteners can penetrate thin work pieces or slip off corners and edges of workplaces, and thus put people at risk.
- For personal safety, use protective equipment such as hearing and eye protection.
- Fastener driving tools are operated by actuating the



trigger using finger pressure.

In addition, fastener driving tool is fitted with a safety yoke which enables the driving operation to be carried out only after the safety yoke of the tool is pressed against a work piece. These tools are marked with an inverted triangle  behind the serial number and are not permitted for use without an effective safety yoke.

A safety yoke is not required on fastener driving tools which accelerate the heaviest usable fasteners to a free flight velocity below an admissible risk of injury. Those fastener driving tools are not marked with an inverted triangle.

## SAFETY INSTRUCTIONS FOR COMPRESSED AIR SYSTEM

- Proper functioning of the fastener driving tool requires filtered, dry and lubricated compressed air in adequate quantities.
- If the air pressure in the line system exceeds the maximum allowable pressure of the fastener driving tool, a pressure reducing valve followed by a downstream safety valve shall additionally be fitted in the supply line to the tool.
- The compressor plant shall be adequately dimensioned in terms of pressure output and performance (volumetric flow) for the consumption which is to be expected. Line sections which are too small in relation to the length of the line (pipes and hoses), as well as overloading the compressor, will result in pressure drops.
- Permanently laid compressed air pipelines should have an internal diameter of at least 19 mm and a corresponding large diameter where relatively long pipelines or multiple users are involved.
- Compressed air pipelines should be laid so as to form a gradient (highest point in the direction to the compressor). Easily accessible water separators should be installed at the lowest points.
- Junctions for users should be joined to the pipelines from above.
- Connecting points for fastener driving tools should be fitted with a compressed air servicing unit (filter/water separator/oiler) directly at the junction point.

## RESIDUAL RISKS

Even if you are operating this product in accordance with all the safety requirements, potential risks of injury and damage remain. The following dangers can arise in connection with the structure and design of this product:

1. Health defects resulting from vibration and noise emission if the product is being used over long periods of time or not adequately managed and properly maintained.
2. Injuries and damage to property due to fasteners or the sudden impact of hidden objects during use.
3. Danger of injury and property damage caused by

flying objects.

## SYMBOLS



Safety alert



CE conformity



Please read the instructions carefully before starting the product.



Wear eye protection.



Wear ear protection.



Lubricate with air tool oil daily.



Keep hands away



Tacker with safety yoke

## SPECIFICATIONS

### FASTENER

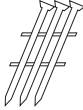
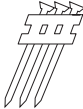
Nail type		15° coil nails, wire collated, Dia. 2.3 - 2.9 mm
		Nail range: 38 - 65 mm
		Head diameter: 5.0 - 6.3 mm
		Collation angle: 15°
		Nail distance: 7 - 8 mm
		15° coil nails, plastic collated, Dia. 2.3 - 2.9 mm
		Nail range: 32 - 65 mm
		Head diameter: 5.0 - 6.3 mm
		Collation angle: 15°
		Nail distance: 7 - 8 mm

### TOOL

Magazine capacity	250 - 300 nails
Air inlet size	6.35 mm (1/4")
Air hose size	9.52 mm (3/8")
Air consumption	1.9 L/cycle at 6.9 bar (100 psi)
Working pressure range	5.5 - 8.3 bar (80 - 120 psi)
Exhaust	Rear adjustable (360°)
Tool weight (no nails)	3.03 kg

### NOISE AND VIBRATION

Noise according to EN 12549:1999 and EN ISO 4871	
A-weighted sound pressure level	$L_{PA}=87.8$ dB(A), $K_{PA}=2.5$ dB
Sound power level	$L_{WA}=100.8$ dB(A), $K_{WA}=2.5$ dB
A-weighted sound pressure level(at working station)	$L_{PA}=91.0$ dB(A), $K_{PA}=2.5$ dB

C-weighted sound pressure level	$L_{PC,peak}=91.8$ dB(A), $K_{PC,peak}=2.5$ dB
Vibration according to ISO 8662-11:1999	
Vibration in the handle	$a_h, W=11.5$ m/s <sup>2</sup> , $K=1.5$ m/s <sup>2</sup>

### INTENDED USE

The tool can be used for the purposes listed below:

- Plywood and fibre cement sheet bracing
- Triple grips, multi-grips and steel bracketry
- Steel angle and flat bracing
- Ceramic tile underlay
- Vinyl and cork underlay
- Exterior cladding
- Blueboard sheeting for rendering
- Timber decking
- Timber fencing
- Pallet and crate assembly

### AIR SUPPLY AND OPERATION

- Ensure air valve (or trigger) is in the "off" position before connecting to the air supply.
- Required air pressure range of 5.5 - 8.3 bar (80 - 120 psi), and an airflow according to specifications.
- Disconnect the product from the compressed air supply before changing accessories or making adjustments.
- Connect the product to the air hose.
- Push the tool against the work surface and squeeze the trigger to drive a fastener.
- Do not use any additional force upon the product.

### ⚠ WARNING

Ensure the air supply is clean and does not exceed 8.3 bar (120 psi) while operating the product. Too high an air pressure and unclean air will shorten the product's life due to excessive wear, and may be dangerous causing damage and/or personal injury.

### ASSEMBLY

#### UNPACKING

This product has been shipped completely assembled.

- Carefully remove the tool and any accessories from the box. Make sure that all items listed in the packing list are included.



### WARNING

Do not use this product if it is not completely assembled or if any parts appear to be missing or damaged. Use of a product that is not properly and completely assembled could result in serious personal injury.

- Inspect the tool carefully to make sure no breakage or damage occurred during shipping.
- Do not discard the packing material until you have carefully inspected and satisfactorily operated the tool.

#### Packing list

- Nailers
- Wrench kit
- Air tool oil
- Moulded carry case
- M8 screw hanger
- Operator's manual

### WARNING

If any parts are damaged or missing do not operate this tool until the parts are replaced. Use of this product with damaged or missing parts could result in serious personal injury.

### WARNING

Do not attempt to modify this tool or create accessories not recommended for use with this tool. Any such alteration or modification is misuse and could result in a hazardous condition leading to possible serious personal injury.

## OPERATION

### WARNING

Do not use oxygen, combustible gases or bottled gases as a power source for this tool. The tool will explode and cause death or serious injury.

### WARNING

Do not allow familiarity with tools to make you careless. Remember that a careless fraction of a second is sufficient to inflict severe injury.

### WARNING

Always wear safety goggles or safety glasses with side shields when operating tools. Failure to do so could result in objects being thrown into your eyes resulting in possible serious injury.

### WARNING

Disconnect the tool from the air supply before leaving the work area, moving the tool to another location, or handing the tool to another person. Failure to do so could result in serious personal injury.

### WARNING

Always wear eye protection. Eye protection does not fit all operators in the same way. Make sure the eye protection chosen has side shields or provides protection from flying debris both from the front and sides.

## PREPARING THE TOOL FOR USE

See figure 1.

### WARNING

Please read and observe these operating instructions before using the tool. Basic safety measures should always be strictly followed to protect against damage to the equipment and personal injury to the user or other people working in the vicinity of operation.

Under normal use conditions, the tool should be lubricated with air tool oil before connecting the tool to an air supply. Add air tool lubricant into the air fitting on the tool once daily with minimal use, or twice a day with heavy use. Only a few drops of oil at a time is necessary. Too much oil will only collect inside the tool and will be noticeable in the exhaust cycle.

Before connecting the tool, check the air compressor gauge to be sure it is functioning within the proper range of 5.5 - 8.3 bar (80 - 120 psi).

## ADJUSTING THE EXHAUST

See figure 2.

The adjustable exhaust on the end cap of the tool allows the operator to direct the exhaust according to operator preference.

To adjust, turn the exhaust cap in the desired direction.

## CONNECTING THE TOOL TO AN AIR SUPPLY

See figure 3.

**⚠ WARNING**

Ensure that the pressure supplied by the compressed air system does not exceed the maximum allowable pressure of the fastener driving tool. Set the air pressure initially to the lower value of the recommended allowable pressure (see Specifications).

**⚠ WARNING**

Empty the magazine to prevent a fastener from being ejected at the next stage of work in the event that internal parts of the fastener driving tool are not in the starting position following maintenance and repair work or transportation.

**⚠ WARNING**

Connect the fastener driving tool to the compressed air supply using suitable pressure hose equipped with quick-action connectors.

**⚠ WARNING**

Check for proper functioning by applying the safety yoke of the fastener driving tool to a piece of wood or wooden material and actuating the trigger once or twice.

This tool is designed to operate on clean, dry compressed air at regulated pressures between 5.5 - 8.3 bar (80 - 120 psi). The correct air pressure is the lowest pressure that will do the job.

**NOTE:** Air pressure that is higher than 8.3 bar (120 psi) may damage the tool.

The tool and air hose must have a hose coupling that allows all pressure to be removed from the tool when the coupling is disconnected.

**⚠ WARNING**

Always use a coupling that discharges all the compressed air in the tool at the time the fitting or hose coupling is disconnected. Using a coupling that does not discharge the compressed air could cause unintended operation and serious personal injury.

**⚠ WARNING**

Do not climb rigging or scaffolding while carrying a tool that is connected to an air hose. Doing so could result in serious personal injury.

Connect the tool to the air supply with a 1/4 in. female quick connector. For maximum tool performance, a 3/8 in. supply line and fittings are required.

## LOADING THE TOOL WITH FASTENERS

See figure 4 - 11.

**⚠ WARNING**

Only those fasteners specified under Specifications may be used. When filling the magazine, hold the tool so that the safety yoke is not pointing towards the operator or any other person or animals.

**⚠ WARNING**

The tool's driving mechanism may cycle when the tool is first connected to the air supply. Always connect the tool to a pressurized air supply before loading fasteners to prevent injury from unintended cycling. Always make sure the tool's magazine is empty at the beginning of each work session, before connecting to an air supply.

1. Connect the tool to the air supply.
2. Press down on the feeder cover latch and open the feeder cover. Then open the magazine cover.
3. Adjust the position of spool for the nail size you are using. The nail will not feed smoothly if the spool is not correctly adjusted. Refer to "Adjusting the spool" section for instructions.
4. Slide the coil of nails onto the spool with the nail pointing down. Uncoil about 7 cm of nails from the coil of framing nails.
5. Close the magazine. The feeder cover should remain open.

**⚠ WARNING**

Keep the tool pointed away from yourself and others when loading fasteners. Failure to do so could result in possible serious personal injury.

6. Insert the first nail into the nail chamber. The first nail should sit in the nose of the tool.
7. Position the second nail between the guides. The nail heads should lie in the track.
8. Securely close the feeder cover, snapping it into place. Be sure that the feeder cover is locked before resuming operation.

**⚠ WARNING**

Use only the fasteners recommended for use with this tool. The use of any other fasteners can result in tool malfunction, leading to serious injuries.

**⚠ WARNING**

Never load fasteners with the safety yoke or trigger activated. Doing so could result in possible serious personal injury.

### WARNING

Do not use fasteners with shank diameter smaller than that stated in Specifications. Doing so may cause fasteners to exit the tool prematurely through the guide track. Do not use hardened fasteners with pneumatic tools. This could lead to excessive wear of the guide body and allow fasteners to exit the back of the guide body, leading to serious personal injury.

### Adjusting the spool

To prevent jamming, always adjust the spool to the correct position for the size nail you are using. There is an adjustment indicator inside the magazine to help you choose the right position.

To adjust the position of spool, rotate it approximately 90° counterclockwise. Raise or lower the spool to the desired position according to the nail length. Rotate the spool clockwise until it snaps to lock it in position.

Position	Nail size
Position 1	32 mm
Position 2	38 mm
Position 3	45 mm
Position 4	50 mm
Position 5	57 - 60 mm
Position 6	65 mm

### DRIVING A FASTENER

See figure 12.

### WARNING

Check the safety yoke before use. If it is deformed or cannot telescope, do not use the tool until it is replaced. Operate with a deformed safety yoke could result in serious personal injury.

### WARNING

Never wedge or hold back the safety yoke mechanism during operation of the tool. Doing so could result in possible serious injury.

Avoid triggering the fastener driving tool if the magazine is empty.

Any defective or improperly functioning fastener driving tool must immediately be disconnected from the compressed air supply and passed to a specialist for inspection.

In the event of longer breaks in work or at the end of the working shift, disconnect the tool from the compressed air supply and it is recommended to empty the magazine.

The compressed air connectors of the fastener driving tool and the hoses should be protected against contamination, the ingress of coarse dust chips, sand, etc. will result in leaks and damage to the fastener driving tool and the couplings.

### Single sequential actuation mode

The tool employs single sequential actuation mode.

1. Connect the tool to the air supply.
2. Grip the tool firmly to maintain control. Position the safety yoke of the tool onto the work surface.
3. Push the tool against the work surface to depress the workpiece contact.
4. Squeeze the trigger to drive a fastener.
5. Allow the tool to recoil away from the work surface as the fastener is driven.
6. Always remove your finger from the trigger when the fastener has been driven.

### WARNING

**During normal use the tool will recoil immediately after driving a fastener. This is a normal function of the tool.** Do not attempt to prevent the recoil by holding the tool against the work. Restriction to the recoil can result in a second fastener being driven from the tool. Grip the handle firmly, let the tool do the work, and do not place second hand on top of tool or near exhaust at any time. Failure to heed this warning can result in serious personal injury.

### SETTING THE AIR PRESSURE

Having checked that the fastener driving tool is functioning correctly, apply the tool to a work piece and actuate the trigger.

Check whether the fastener has been driven into the work piece in accordance with the requirements.

- If the fastener is protruding, increase the air pressure in increments of 0.5 bar, checking the result after each new adjustment;
- If the fastener is driven into an excessive depth, reduce the air pressure in increments of 0.5 bar until the result is satisfactory.
- It is preferred to adjust the depth adjustment knob to reach the good fastening effect.

Work with the lowest possible air pressure. This will give you three significant advantages;

1. Energy will be saved,
2. Less noise will be produced,
3. A reduction in fastener driving tool wear will be achieved.

The amount of air pressure required will depend on the size of the fastener and the workpiece material.

Begin testing the depth of drive by driving a test fastener into the same type of workpiece material used for the

actual job.

Drive a test fastener with the air pressure set at 6.2 - 6.5 bar (90 - 95 psi). Raise or lower the air pressure to find the lowest setting that will perform the job with consistent results.

It may be possible to achieve the desired depth with air pressure adjustments alone. If finer adjustments are needed, use the drive depth adjustment on the tool.

### DRIVE DEPTH ADJUSTMENT

See figure 13.

The driving depth of the fastener may be adjusted. It is advisable to test the depth on a scrap workpiece to determine the required depth for the application.

To determine depth of drive, first adjust the air pressure and drive a test fastener. To achieve the desired depth, use the drive depth adjustment on the tool.

1. Disconnect the tool from the air supply.
2. Turn the depth adjustment knob left or right to change the driving depth.
3. Reconnect the tool to the air supply.
4. Drive a test fastener after each adjustment until the desired depth is set.

### REMOVING FASTENERS FROM THE TOOL

1. Disconnect the tool from the air supply.

#### WARNING

Disconnect the tool from the air supply and empty the magazine before performing maintenance. Failure to do so could result in serious personal injury.

2. Press down on the feeder cover latch and open the feeder cover. Then open the magazine cover.

**NOTE:** Always keep fingers clear of fastener track of magazine to prevent injury from unintended release of the pusher.

3. Lift the nail strip from the spool and remove the remaining coil of nails.
4. Close the magazine.
5. Securely close the feeder cover, snapping it into place. Be sure that the feeder cover is locked.

### CLEARING A JAMMED FASTENER

See figure 14-15.

#### WARNING

Disconnect the tool from the air supply and empty the magazine before clearing a jammed fastener. Failure to do so could result in serious personal injury.

If a fastener becomes jammed in the tool, disconnect the air hose and keep the tool pointed away from you while clearing the jam.

1. Disconnect the tool from the air supply.
2. Open the feeder cover.
3. Remove fasteners from the tool.
4. Insert a rod into the driving mechanism. Tap the rod with a hammer to push the driver mechanism back, freeing the fastener jam.
5. Remove the bent fastener with a slotted screwdriver.
6. Reconnect the tool to the air supply.
7. Reinstall fasteners.

### ATTACHING THE SCREW HANGER

See figure 16-17.

1. Remove the rubber cap from the screw hole at the rear of tool.
2. Attach the screw hanger to the rear of the tool. Tighten the screw hanger by screwing it. (Tightening torque range: 5.5-6.5 N.m)

### MAINTENANCE

#### WARNING

When servicing use only identical replacement parts. Use of any other parts may create a hazard or cause product damage.

#### WARNING

Always wear eye protection with side shields marked to comply with one of the following standards:

- Australian Standard – AS/NZS 1337
- European Standard – CE EN166
- American Standard – ANSI Z87.1

Failure to do so could result in objects being thrown into your eyes resulting in possible serious injury.

#### WARNING

Disconnect the tool from the air supply and empty the magazine before performing maintenance. Failure to do so could result in serious personal injury.

### GENERAL MAINTENANCE

Avoid using solvents when cleaning plastic parts. Most plastics are susceptible to damage from various types of commercial solvents and may be damaged by their use. Use clean cloths to remove dirt, dust, oil, grease, etc.

#### WARNING

Do not at any time let brake fluids, gasoline, petroleum-based products, penetrating oils, etc., come in contact with plastic parts. Chemicals can damage, weaken or destroy plastic which may result in serious personal injury.

## COLD WEATHER OPERATION

For cold weather operation, near and below freezing, the moisture in the air line may freeze and prevent tool operation. We recommend the use of air tool lubricant or permanent antifreeze (ethylene glycol) as a cold weather lubricant.

### WARNING

Do not store tools in a cold weather environment to prevent frost or ice formation on the tools' operating valves and mechanisms that could cause tool failure.

**NOTE:** Some commercial air line drying liquids are harmful to "O" rings and seals. Do not use these low temperature air dryers without checking compatibility.

## AIR SUPPLY PRESSURE AND VOLUME

Air volume is as important as air pressure. The air volume supplied to the tool may be inadequate because of undersize fittings and hoses, or from the effects of dirt and water in the system. Restricted air flow will prevent the tool from receiving an adequate volume of air, even though the pressure reading is high. The results will be a slow operation or reduced driving power. Before evaluating tool problems for these symptoms, trace the air supply from the tool to the supply source for restrictive connectors, low points containing water and anything else that would prevent full volume flow of air to the tool.

## REQUIRED DAILY CHECKLIST

1. Disconnect the air supply from the tool and remove all fasteners.
2. Check all screws, nuts, bolts, and pins on the tool. If any of these are loose, they must be tightened with the appropriate size wrench.
3. Press the safety yoke against a workpiece to ensure that it moves smoothly.
4. With the safety yoke depressed, pull the trigger. The trigger should move smoothly, without binding.
5. While the tool is not loaded, connect the appropriate air supply at 5.5 bar (80 psi) to the tool.
  - Without pulling the trigger, press the safety yoke against a workpiece several times. The tool must not operate.
  - With the safety yoke not engaged on the workpiece, point the tool down and away from you and other persons, and pull the trigger several times. Hold the trigger in this position for a minimum of 5 seconds. The tool must not operate.
  - Press the safety yoke firmly against the workpiece, and pull the trigger. The tool must operate.
  - With the safety yoke still depressed, release the trigger. The driver must return to its up position.
6. If the tool successfully meets all the requirements in this checklist, it is ready for use. Load the proper fasteners for the desired application.

7. Set the depth of drive according to the "drive depth adjustment" section in this manual. Repeat this checklist before using the tool each day, or if the tool is dropped or damaged in any way.

### WARNING

Do not use any attachments or accessories not recommended by the manufacturer of this tool. The use of attachments or accessories not recommended can result in serious personal injury.

## LUBRICATION

An automatic in-line filter-regulator-lubricator is recommended (Fig. 15) as it increases product life and keeps the product in sustained operation. The in-line lubricator should be regularly checked and filled with air tool oil.

Proper adjustment of the in-line lubricator is performed by placing a sheet of paper next to the exhaust ports and actuate the tool 10 - 15 times without fasteners loaded. The lubricator is properly set when a light stain of oil collects on the paper. Excessive amounts of oil should be avoided.

If it becomes necessary to store the product for an extended period of time (overnight, weekend, etc.), it should receive a generous amount of lubrication at that time. Actuate the tool 10 - 15 times without fasteners loaded to ensure oil has been evenly distributed throughout the product. The product should be stored in a clean and dry environment.

- It is most important that the product be properly lubricated by keeping the air line lubricator filled and correctly adjusted. Without proper lubrication the product will not work properly and parts will wear prematurely.
- Use correct lubricant in the air line lubricator. The lubricator should be of low air flow or changing air flow type, and should be kept filled to the correct level. Use only recommended lubricants, specially made for pneumatic applications. Substitutes may harm the rubber compounds in the product's O-rings and other rubber parts.

### IMPORTANT!

See figure 18.

If a filter/regulator/lubricator is not installed on the air system, air operated tools should be lubricated at least once a day or after 2 hours of work with 2 - 6 drops of oil, depending on the work environment, directly through the male fitting in the tool housing.

## TROUBLESHOOTING

PROBLEM	CAUSE	POSSIBLE SOLUTION
Air leak near the top of the tool or in the trigger area.	Loose screws. Worn or damaged O-rings or seals.	Tighten screws. Install overhaul kit.
Air leak near the bottom of the tool.	Loose screws. Worn or damaged O-rings or seals.	Tighten screws. Install overhaul kit.
Tool does nothing or operates sluggishly.	Inadequate air supply. Inadequate lubrication. Worn or damaged O-rings or bumper.	Verify adequate air supply. Lubricate tool. Install overhaul kit.
Tool jams frequently.	Incorrect fasteners. Damaged fasteners. Loose magazine. Dirty magazine. Worn or damaged driver.	Verify that fasteners are the correct size. Replace fasteners. Tighten screws. Clean magazine. Install driver maintenance kit.

## PARTS LIST

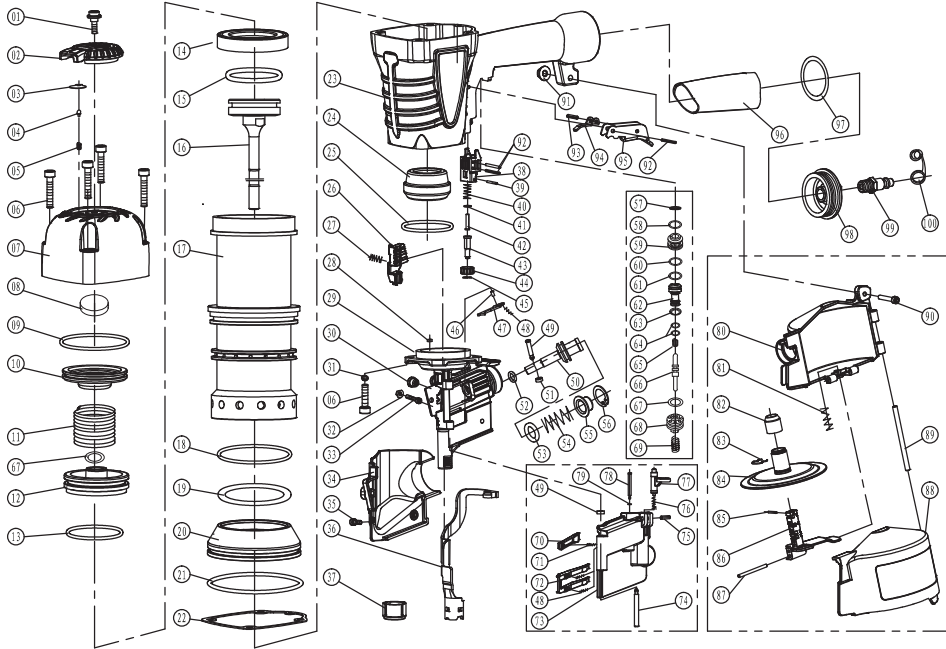

No.	Description	No.	Description	No.	Description	No.	Description
1	Bolt	28	Sealing washer	55	Piston spring seat	82	Tray cover
2	Air deflector	29	Pusher	56	Circlip	83	Circlip
3	Spring slice	30	Magnet	57	Washer	84	Adj. plate
4	Dowel	31	Washer	58	O-ring 16 x 1.6	85	Pin 2.5 x 12
5	Spring	32	Bolt	59	Valve seat	86	Adjusting seat
6	Bolt M6 x 25	33	Bolt M4 x 16	60	O-ring 6.1 x 1.8	87	Pin 4 x 50
7	Cylinder cover	34	Protective shield	61	O-ring 6.4 x 2	88	Magazine cover
8	Seal washer	35	Bolt M5 x 12	62	Valve bush	89	Pin 4 x 60
9	O-ring 48.7 x 2.65	36	Safety yoke	63	O-ring 9 x 1.8	90	Nut M5
10	Spring seat	37	Nose cap	64	O-ring 2.4 x 1.6	91	End cap
11	Spring	38	Adjustment bracket	65	Switch spring	92	Pin 3 x 30
12	Air valve	39	Pin	66	Switch lever	93	Pin 2.5 x 18
13	O-ring 46.2 x 3.55	40	Spring	67	O-ring 18 x 2.65	94	Safety plate
14	Collar	41	Split washer	68	Switch seat	95	Trigger
15	O-ring 38 x 3.5	42	Shaft	69	Trigger spring	96	Grip
16	Main piston	43	Guiding screw	70	Nail stop	97	O-ring 36.3 x 3.55
17	Cylinder	44	Adjusting screw	71	Spring	98	End cap
18	O-ring 51 x 2.65	45	Circlip	72	Nail presser	99	Air inlet
19	Washer	46	Pin (2.5 x 10)	73	Nail cover	100	Air inlet cover
20	Collar	47	Stop pin	74	Dowel		
21	O-ring 75 x 2.65	48	Spring	75	Pin 3 x 10		
22	Washer	49	Pawl dowel	76	Spring		
23	Gun body	50	Piston	77	Trigger piece		
24	Bumper	51	Pin bush	78	Shaft pin		
25	O-ring 46 x 2	52	O-ring 8.75 x 1.8	79	O-ring 1.7 x 2		
26	Pawl	53	O-ring 17 x 2.65	80	Magazine		
27	Pawl spring	54	Spring	81	Spring		



**Techtronic Industries (Australia) Pty. Ltd.**  
Level 1, 660 Doncaster Road  
Doncaster, VIC 3108, Australia

**Techtronic Industries New Zealand Ltd.**  
18-26 Amelia Earhart Avenue  
Mangere, Auckland 2022, New Zealand

