

BOSE99XP

90cm, 9 Function, Built in Electric Oven



Model Code

BOSE99XP

Description

90cm 9 Function Electric Oven

Accessories

Included Accessories:

- 2 x safety anti-tip shelves
- 1 x enamelled baking tray
- 1 x grill pan insert
- 1 x grill handle
- Catalytic liners – rear and sides

Warranty

BLANCOCare™ 2 years parts & labour

Features

Benefits

Large Oven Capacity

At 84 litres, this large capacity oven will accommodate even the biggest of meals.

Triple Glazed Thermo-reflective Door

The triple layered door with thermo-reflective glass offers not only a cooler to touch surface but also increases the energy efficiency as the heat is retained within the oven.

Fully Programmable

The fully programmable touch control operation enables you to set the start and finish time of your cooking where the oven will automatically switch off when finished.

Catalytic Self-cleaning Liners

On the rear and sides of the oven, these self-cleaning liners means less time spent cleaning your oven. Catalytic liners absorb grease and dirt from everyday cooking, and then burn it off at up to about 230°C.

Black Enamelled Cavity

The oven is made so that it's simple to clean. The smooth black enamel is not only easy to clean but also resistant of acidic spills.

Specifications

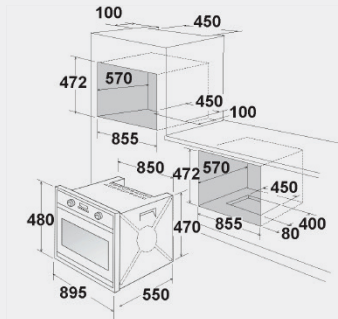

Product Dimensions:	H480 x W895 x D550 mm
Cut-out size (proudmount):	H472 x W855 x D570mm
Cut-out size (flushmount):	H483 x W898 x D570mm
Power Requirement:	220-240V – 50Hz
Electrical connection:	15 amp – cable supplied – hard wired
Oven volume:	84 litre capacity
Oven Functions:	Fan Forced, Fan Forced with Bottom Element, Fan Grill, Fan Assist, Half Grill, Full Grill, Traditional, Bottom Element, Light
Lighting:	25 W

Oven Elements:

Grill element:	2750 W
Oven bottom element:	1250 W
Fan forced element:	2300 W
Hot air fan motor:	20-25 W
Cooling fan motor:	25 W

NOTE: It is advisable to check dimensions of physical product when measuring for installation and before doing any cut outs.
*Due to continual product development the information provided is not final and may be subject to change.