

# STORAGE STATION

## 2090H x 1820W x 540Dmm

**ITEM NO: GOS097**

**POWDER  
COATED  
BLACK**

**625kg**  
BENCHTOP &  
PER SHELF

**Very Important:** Unpack the unit and confirm that you have all the parts listed. Assemble the unit on a solid, level surface. Avoid carpet. You will need the assistance of a second person during assembly. **Safety tip:** For added safety and support we recommend you fix unit to a wall. **You will need the following:** Rubber mallet, Phillips head screwdriver, adjustable spanner and 3mm drillbit.

**WARNING**

SERIOUS INJURY OR  
DEATH CAN BE CAUSED BY  
TOPPLING FURNITURE

**TO HELP PREVENT A TIP-OVER:**

•Anchor this product to a wall or other suitable surface with the provided "Tip over prevention kit". •Check anchors regularly









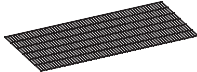

FOR MORE INFORMATION SEARCH: [www.productsafety.gov.au](http://www.productsafety.gov.au)

### SAFETY TIP:

When assembling or installing this product wear protective gloves and eyewear.

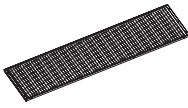
**NOTE:** This product has been tested to safely carry a load of up to 2500kg evenly distributed, when properly installed and maintained. Heaviest items to be loaded on lowest shelves.

#### Parts List

	WIRE SHELVES	X 3
	FOOT END CAPS	X 4
	BRACKETS 'A'	X 7
	BRACKETS 'B'	X 8
	BRACES 'C'	X 8
	LEGS 'D'	X 4
	TIMBER BENCHTOP 'E'	X 1
	BOTTOM PEGBOARD 'F'	X 1
	TOP PEGBOARD 'G'	X 1
	M16 X 13MM PANHEAD HEXBOLT 'H'	X 4
	HEX NUT M6 'J'	X 4
	M5 X 16MM SELF TAPPING SCREW 'K'	X 4

NOT TO SCALE

**PLEASE NOTE:** Tip-over prevention kit included (refer to last page for installation).

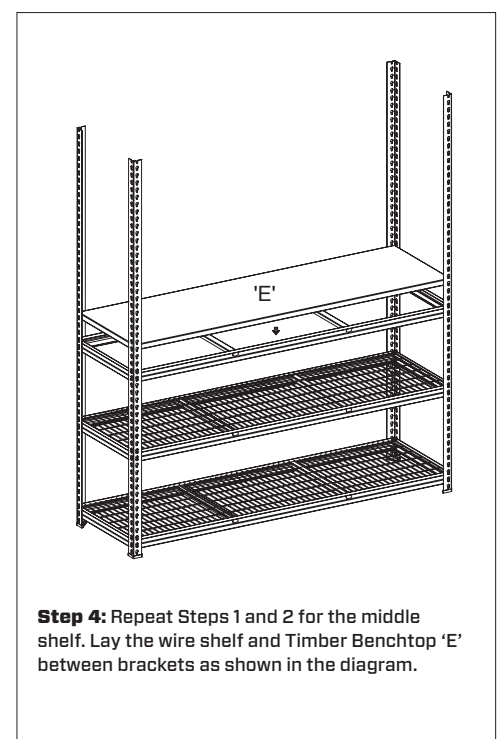
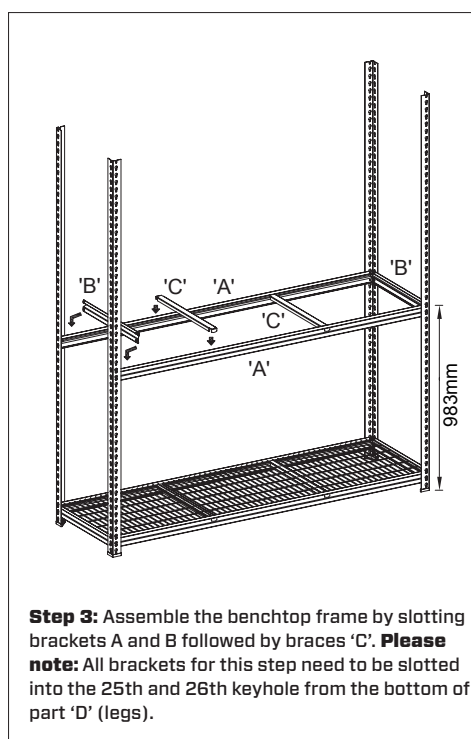
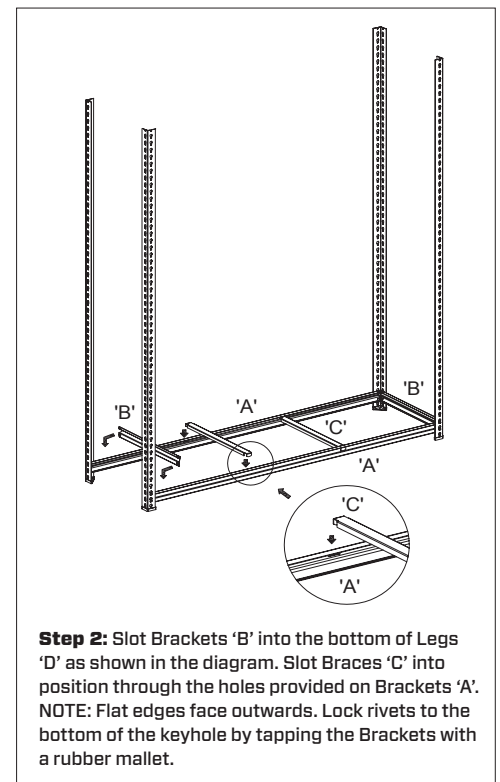
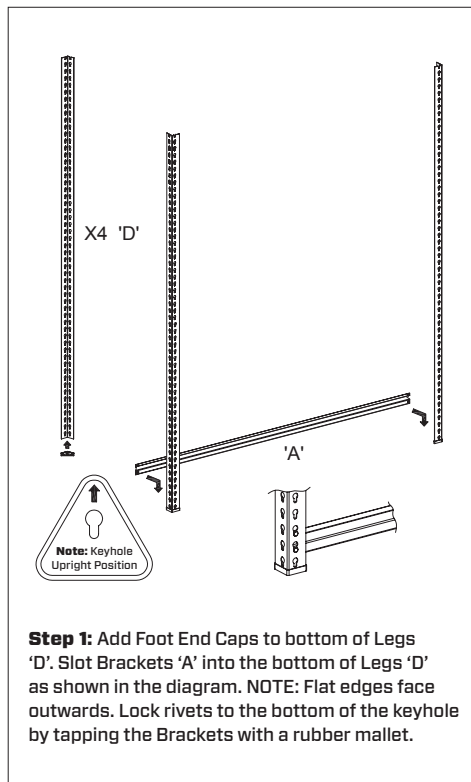

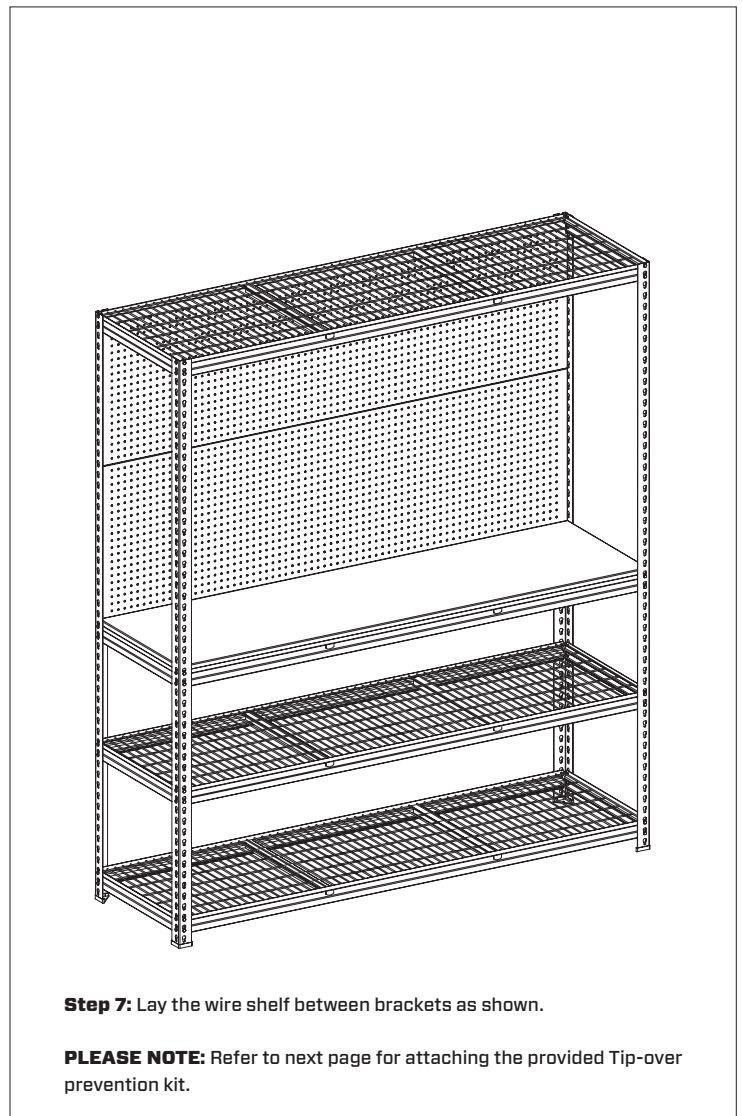
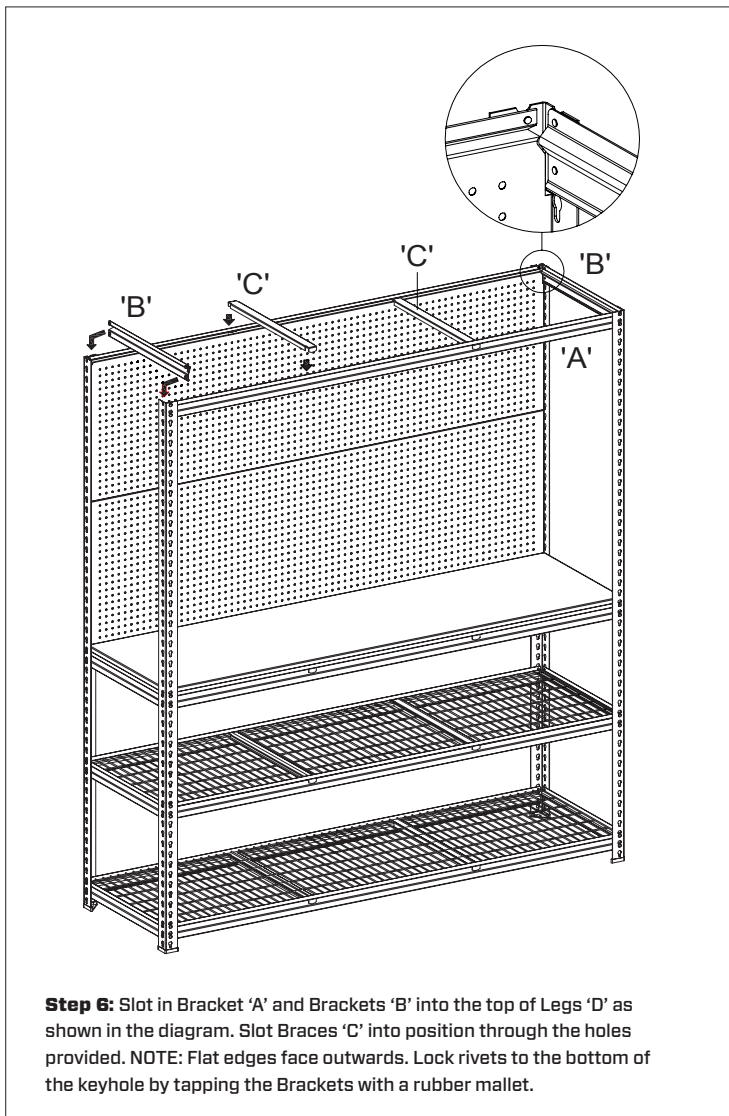
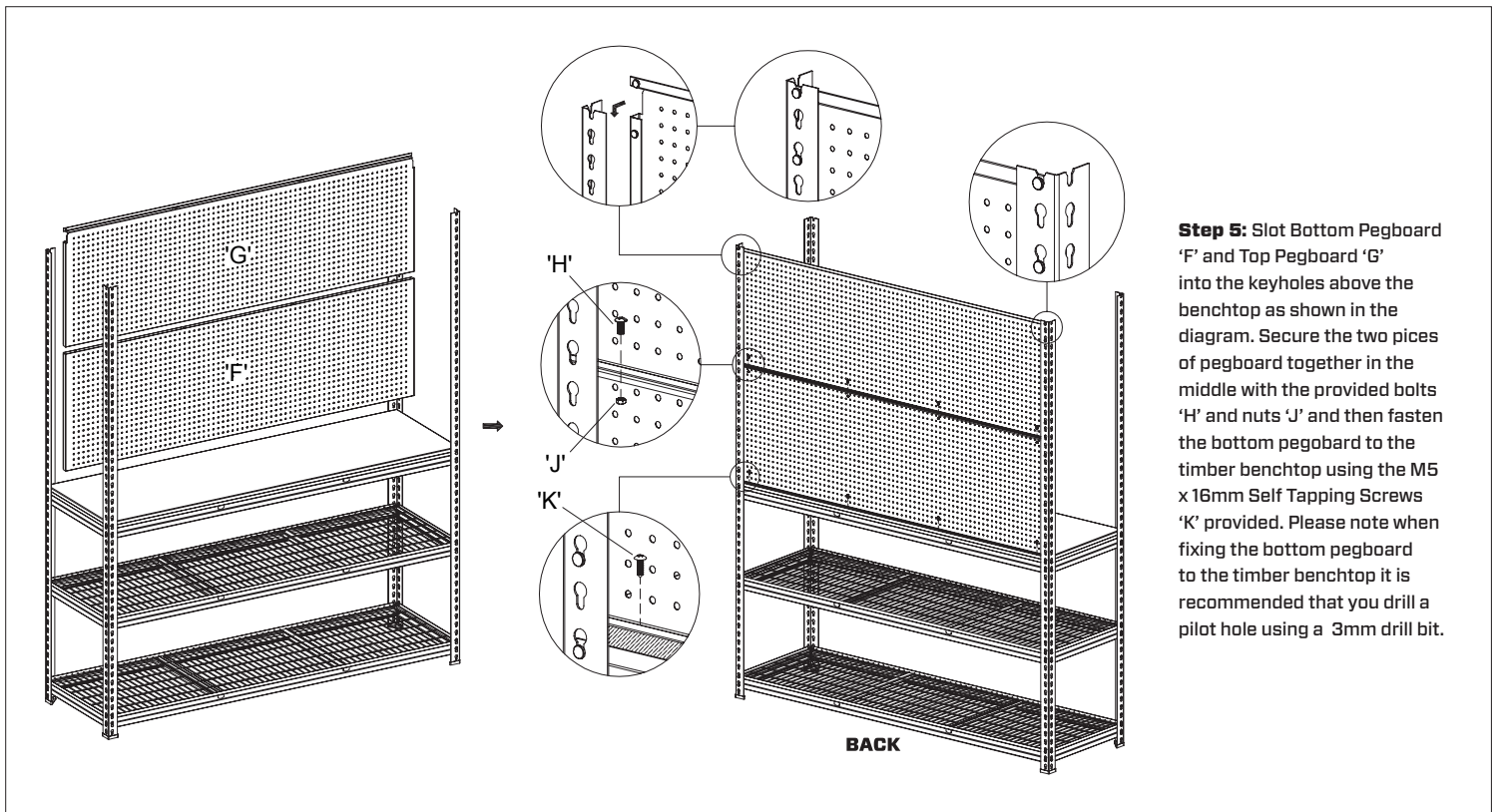

**WARRANTY CONDITIONS:** Any claim under this warranty must be made within 1 year of the date of purchase of the product. To make a claim under this warranty, take the product (with proof of purchase) to any Bunnings store (see [www.bunnings.com.au](http://www.bunnings.com.au) for store locations). Pinnacle Hardware bears reasonable, direct expenses of claiming under the warranty. You may submit details and proof of purchase to our support centre for consideration. The warranty covers manufacturer defects in materials, workmanship and finish under normal use. This warranty is provided in addition to other rights and remedies you may have under law: Our goods come with guarantees that cannot be excluded under the Australian consumer law or Consumer Guarantees Act 1993 (NZ). You are entitled to a replacement or refund for a major failure and compensation for any other reasonably foreseeable loss or damage. You are also entitled to have the goods repaired or replaced if the goods fail to be of acceptable quality and the failure does not amount to a major failure. This warranty excludes damage resulting from product misuse or product neglect, any modifications, additions or alterations to the product including the addition of extra shelves. Additions or modifications can compromise the structure and safety of the product. The warranty covers domestic use only and does not apply to commercial applications. This warranty is given by Pinnacle Hardware, ABN 87 614 496 196, 28 Hudson Court, Keysborough Vic 3173, 1800 349 776, Email: [support@pinnacle.net.au](mailto:support@pinnacle.net.au). New Zealand customers please contact HARCO (Harkness & Young Ltd), Email: [sales@harknessyoung.co.nz](mailto:sales@harknessyoung.co.nz). 'Pinnacle' is a trademark. © Pinnacle Hardware. Suitable for model number GOS097.

## TIP OVER PREVENTION KIT:

**PLEASE NOTE:** We strongly recommend that this product is permanently fixed to a wall. Please use the provided “Tip over prevention kit” to securely fix product to your wall.



**Parts list:**

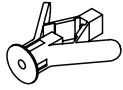

**A x2**



**B x2**



**C x2**



**D x2**

**Final Step (For Brick/Masonry wall):**

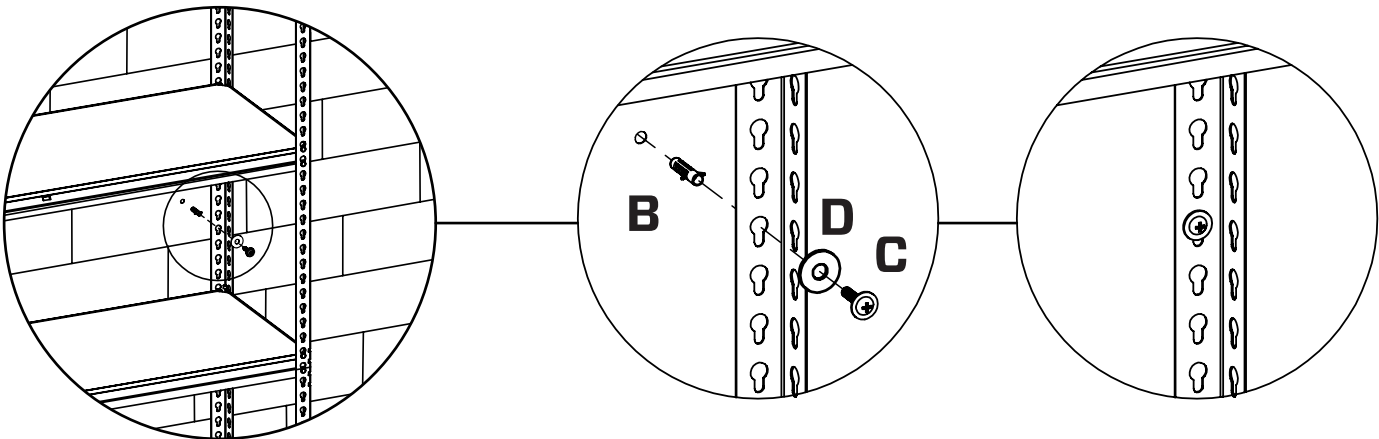

**Final Step (For Plaster wall):**

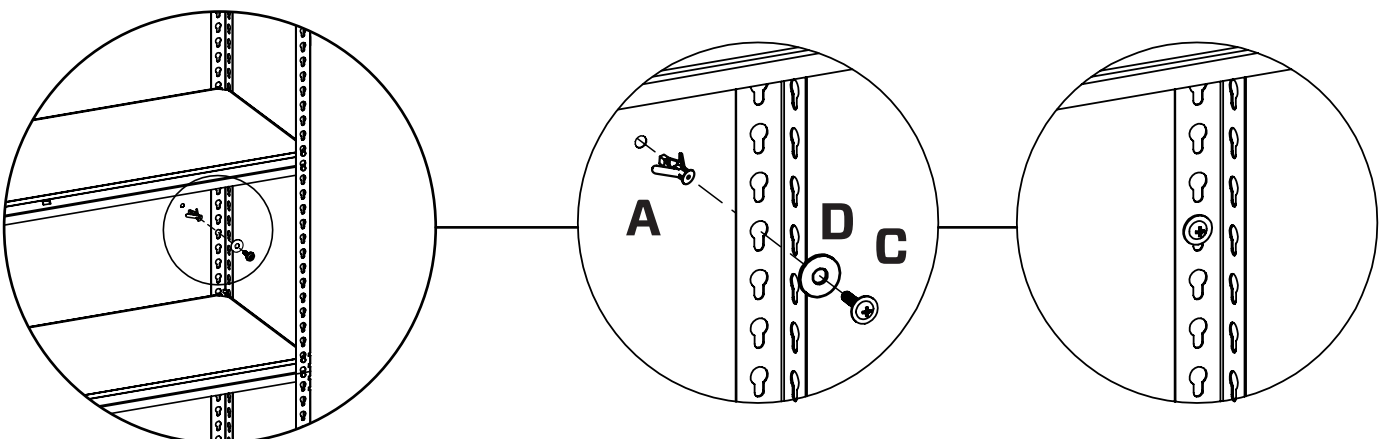

**It is STRONGLY RECOMMENDED that you ANCHOR this product.**

Toppling furniture can cause serious injuries and death.

A “Tip over prevention kit” has been provided with this product to stop your furniture from tipping forward, it is strongly recommended that you **securely attach this product** to a wall or other solid surface using the provided fixings.

**IMPORTANT:** Regularly check that anchors are securely maintained. Stability of tall items may be affected by thick pile carpet or uneven floors.

**CAUTION:**

For your safety when attaching the anchor fixings, please note the following:

- Check for any electrical wires or plumbing inside the wall before drilling any holes (if you are unsure please seek professional advice from a qualified tradesperson)
- Walls are constructed from different materials, for example, masonry (solid brick) or plasterboard lined cavity walls (hollow). It is important that you use the appropriate wall fixings for your wall type.