

GE-PP 1100 N-A SUBMERSIBLE CONSTANT PRESSURE PUMP 1100W



Einhell Germany AG

INSTRUCTION MANUAL

TECHNICAL DATA

| | |
|-------------------------|------------------|
| Input: | 220-240V ~ 50Hz |
| Motor: | 1100W |
| Max. Flow Rate: | 6,000l/h |
| Max. Head: | 45m |
| Max. Immersion: | 12m |
| Max. Delivery Pressure: | 4.5 bar |
| Power Cord Length: | 15m |
| Max Particle Size: | Ø1mm Clean Water |
| Outlet: | 25mm (1") Female |
| Water Temp.: | 1°C - 35°C |
| IP Rating: | IPX8 |
| Weight: | 10.4kg |

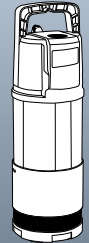
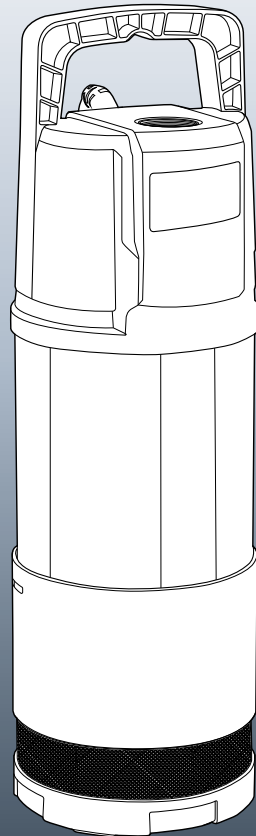

Submersible Pump

ITEMS SUPPLIED



WARRANTY

IN ORDER TO MAKE A CLAIM UNDER THIS WARRANTY YOU MUST RETURN THE PRODUCT TO YOUR NEAREST BUNNINGS WAREHOUSE WITH YOUR BUNNINGS REGISTER RECEIPT. PRIOR TO RETURNING YOUR PRODUCT FOR WARRANTY PLEASE TELEPHONE OUR CUSTOMER SERVICE HELPLINE:

Australia 1800 069 486

New Zealand 0508 069 486

TO ENSURE A SPEEDY RESPONSE PLEASE HAVE THE MODEL NUMBER AND DATE OF PURCHASE AVAILABLE. A CUSTOMER SERVICE REPRESENTATIVE WILL TAKE YOUR CALL AND ANSWER ANY QUESTIONS YOU MAY HAVE RELATING TO THE WARRANTY POLICY OR PROCEDURE.

The benefits provided under this warranty are in addition to other rights and remedies which are available to you at law.

Our goods come with guarantees that cannot be excluded at law. You are entitled to a replacement or refund for a major failure and for compensation for any other reasonably foreseeable loss or damage. You are also entitled to have the goods repaired or replaced if the goods fail to be of acceptable quality and the failure does not amount to a major failure.

Generally you will be responsible for all costs associated with a claim under this warranty, however, where you have suffered any additional direct loss as a result of a defective product you may be able to claim such expenses by contacting our customer service helpline above.

2 YEAR WARRANTY

Your product is guaranteed for a period of **24 months from the original date of purchase** and is intended for DIY (Do It Yourself) use only. If a product is defective it will be replaced in accordance with the terms of this warranty. Warranty excludes consumable parts, for example: O-rings, bearings, seals and gaskets.

WARNING

The following actions will result in the warranty being void.

- If the tool has been operated on a supply voltage other than that specified on the tool.
- If the tool shows signs of damage or defects caused by or resulting from abuse, accidents or alterations.
- Failure to perform maintenance as set out within the instruction manual.
- If the tool is disassembled or tampered with in any way.

PRODUCT LAYOUT

SUBMERSIBLE CONSTANT PRESSURE PUMP

1. Handle
2. Power Cord
3. Outlet
4. Pump Housing
5. Intake Filter Screen
6. Base

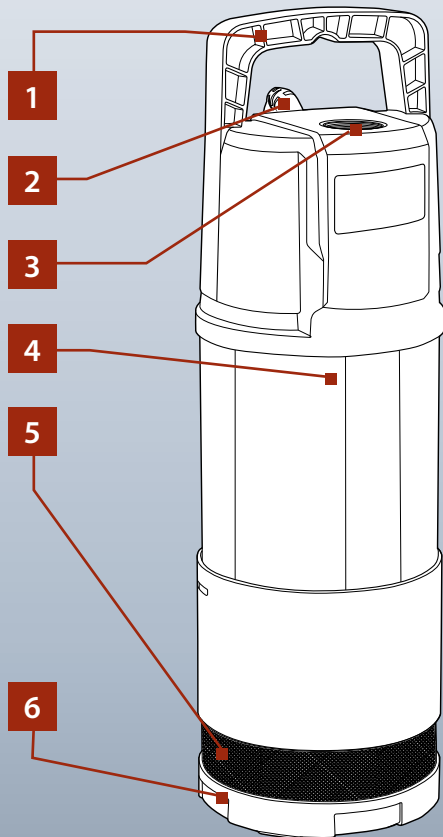

ASSEMBLY

1. HOSE ADAPTOR



WARNING: ENSURE THE TOOL IS SWITCHED OFF AND DISCONNECTED FROM THE POWER SUPPLY BEFORE PERFORMING ANY OF THE FOLLOWING ASSEMBLY.

1. Screw a suitable connector (not included) into the pump housing outlet by rotating in a clockwise direction.

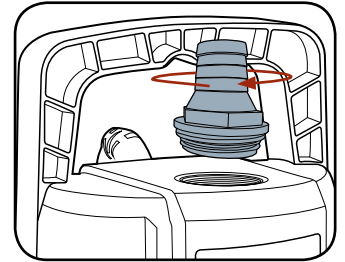

2. Securely attach the hose/tube to the connector, fit hose clamps (not included) if you are using flexible hose or tube, and tighten well.

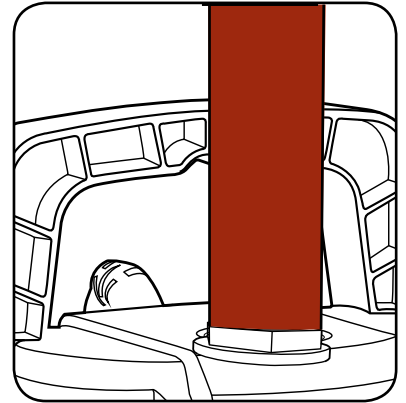

NOTE: The maximum pumping rate is possible only with the largest possible line diameter; if smaller hoses or pipes are connected, the pumping rate will be reduced.

PREPARATION

2. SETUP

Before starting, perform a few simple checks:



CAUTION: NEVER CARRY, LIFT OR PULL UP THE PUMP BY THE POWER CORD. THIS WILL DAMAGE THE UNIT.

1. Ensure the outlet hose is connected correctly.
2. Ensure the distance from the surface of the water to the highest point that you wish to deliver the water does not exceed 45 metres.

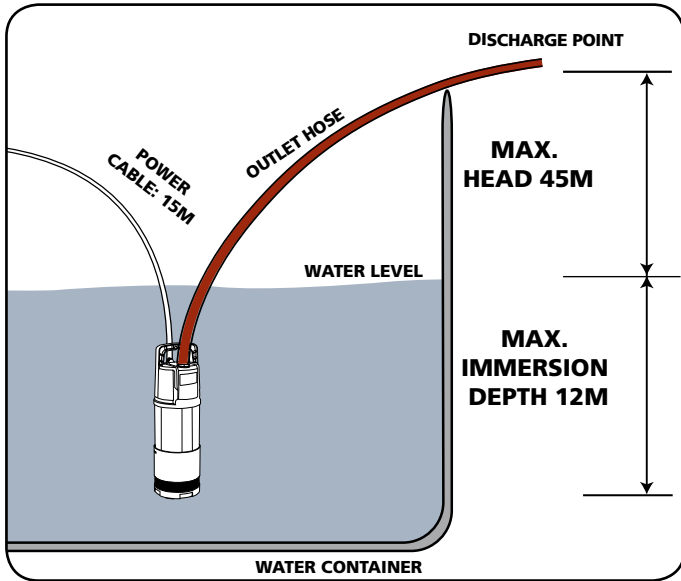

3. Ensure the pump is placed on a flat and level surface, there are no obstructions to the suction base and it is clear of mud or sediment.



CAUTION: THIS PRODUCT IS INTENDED FOR PUMPING WATER IN A HOME DOMESTIC APPLICATION. DO NOT USE IT FOR CORROSIVE, ABRASIVE, EXPLOSIVE OR DANGEROUS LIQUIDS.

4. Ensure the pump is stable and won't fall over.

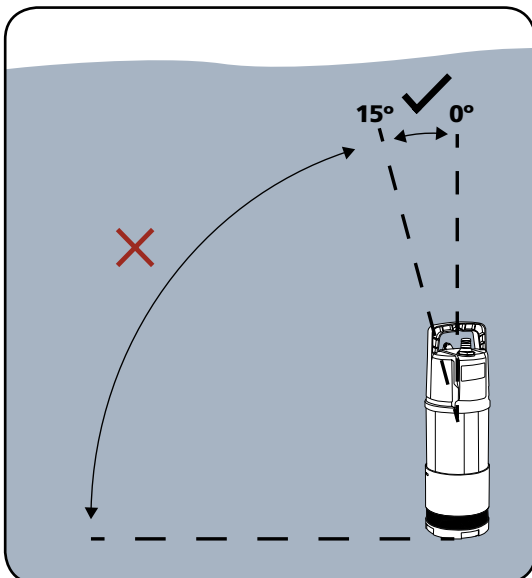

OPERATION

3. OPERATE



WARNING! THE POWER SUPPLY FOR THIS PRODUCT MUST BE PROTECTED BY A RESIDUAL CURRENT DEVICE (RATED AT 30MA OR LESS). A RESIDUAL CURRENT DEVICE REDUCES THE RISK OF ELECTRIC SHOCK.



IMPORTANT: BEFORE SUBMERGING THE PUMP IN WATER, UNWRAP THE POWER CABLE AND ENSURE THE PLUG IS CLEAR OF ANY DAMP LOCATIONS.

1. Immerse the pump in the water. For deep water, use a rope (not included) and secure it to the handle. Set the pump in the desired position within the work area or tank.

NOTE: Ensure that the pump is at least 120mm under the surface of the water

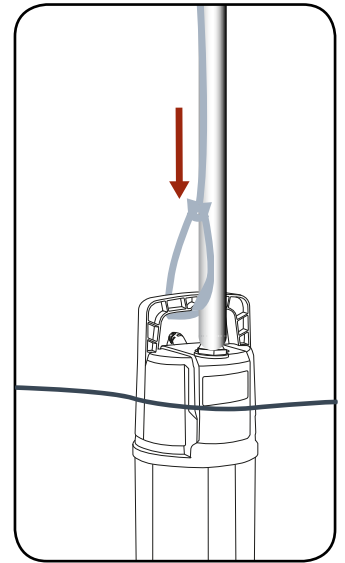

2. Insert the plug into the mains power socket. **The pump will start 3 seconds after the power is switched on.**

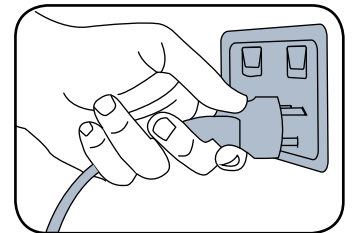

3. To stop operation, turn off the mains power.



CAUTION: YOUR PUMP HAS THE CAPACITY TO PUMP WATER WITH A NON SOLID PARTICLE SIZE OF UP TO 1MM IN DIAMETER, CLEAN WATER.

Automatic Mode

The pump builds up pressure (e.g. the water tap is closed) and then switches off automatically. This is due to the integrated non-return valve, the pressure in the hose will be maintained until water is removed again.

When the pressure drops below 2.5 bar, the pump will switch on again automatically.

Dry-Running Protection

The pump will be switched off automatically when there is no longer any water for pumping.

The pump will perform a restart test for water in cycles of 30 seconds ON / 5 seconds OFF (4x) in a 24 hour period.

As soon as the pump is immersed again in water to a depth of at least 120mm, it will be ready for operation again.

MAINTENANCE

4. CLEANING



IMPORTANT: THE PUMP SHOULD BE CLEANED WITH CLEAR WATER AFTER EACH USE.



WARNING!: ENSURE THE TOOL IS DISCONNECTED FROM THE POWER SUPPLY BEFORE PERFORMING ANY OF THE FOLLOWING OPERATIONS.

If a lot of deposits collect in the housing, the bottom part of the pump must be dismantled as follows:

1. Undo the 8 screws on the underside of the pump and remove the base.

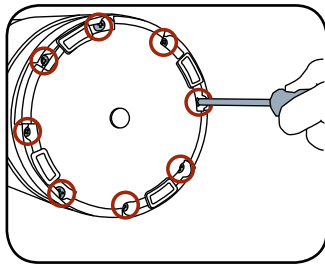

2. Remove the filter screen.

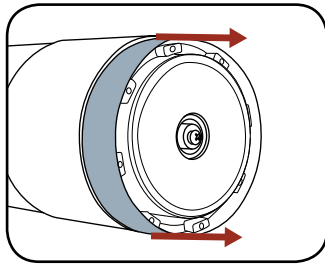

3. Remove the extension ring.

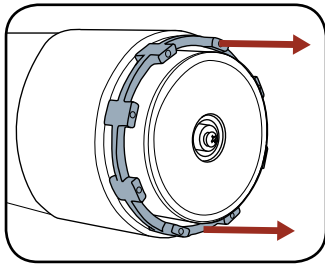

4. Remove the water cover.

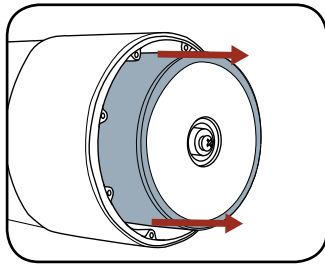

5. Clean all parts removed and the exposed base of the pump with clean water.

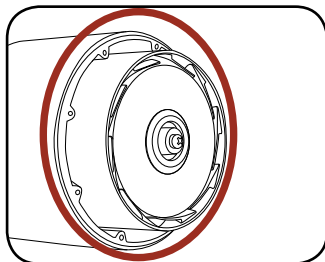

IMPORTANT: DO NOT PUT DOWN OR REST THE PUMP ON THE EXPOSED BASE.

6. Assemble in reverse order.

General Maintenance



- When not in use, the pump should be stored in a dry, frost free location, keep out of children's reach.
- Keep the pumps suction base clear of debris at all times.

Note: Einhell will not be responsible for any damage or injuries caused by repair of the pump by an unauthorised person or by mishandling.

TROUBLESHOOTING

| Problem | Possible Cause | Solution |
|---|---|---|
| The pump does not start, or pump water | <p>Pump is not connected to the power supply</p> <p>Float switch has not been activated, water level too low</p> <p>The impellor is stuck</p> <p>The thermal overload protection is activated</p> <p>The motor is damaged</p> | <p>Check that the pump is connected to the mains power supply</p> <p>Manually raise the position of the float switch</p> <p>Turn pump off and inspect and clean obstruction</p> <p>Wait for the motor to cool and it will automatically start operation</p> <p>Contact Einhell customer service</p> |
| The pump does not supply water when the motor is running | <p>The suction base is obstructed/blocked</p> <p>Air lock in the hose/tube and/or pump (air bubbles)</p> <p>Discharge hose/tube (not included) is kinked or damaged</p> | <p>Clean the suction base of any foreign matter and debris</p> <p>Perform several start-ups in order to remove all the air or lift and tilt the pump slightly while the pump is running</p> <p>Un-kink the discharge hose/tube. Or replace hose/tube</p> <p>Disconnect the mains power and check the discharge outlet and filter for any foreign matter</p> |
| The pump flow rate is reduced | <p>The suction base is partially obstructed/blocked</p> <p>The hose/tube is obstructed</p> <p>Air leak in the suction line or joints</p> <p>Incorrect assembly leads to air and water leakage in the discharge lines</p> | <p>Clean the suction base of any foreign matter and debris</p> <p>Remove the obstructions</p> <p>Check the suction line connections for air leaks and tighten or fix where found</p> <p>Ensure the discharge lines are the correct length and all assembly instructions are adhered to</p> |
| Hose/tube does not stay on the connector/adaptor when water is travelling through | The hose/tube is slightly wider than the dimension of the connector/adaptor. | An adhesive can be used inside the hose/tube to prevent this or Teflon tape can be fixed around the connector/adaptor or a hose clamp can be used |
| The pump operates intermittently | <p>The suction base is obstructed/blocked</p> <p>Incorrect voltage is being used</p> <p>The fluid contains particles thicker than 1mm</p> <p>The motor is faulty or damaged</p> | <p>Clean the suction base of any foreign matter and debris</p> <p>Ensure the pump is connected into 230-240V power supply</p> <p>Ensure the pump is not being used with particles thicker than 1mm</p> <p>Contact Einhell customer service</p> |

SYMBOLS

| | | | |
|--|---|---|-------------------------------|
| V | Volts | Hz | Hertz |
| ~ | Alternating current | W | Watts |
| /min | Revolutions or reciprocation per minute | n₀ | No load speed |
| l | Litres | °C | Degrees celsius |
| p/hr | Per hour | kPa | Pressure rating (kilopascals) |
| bar | Pressure rating | F | Insulation class |
| PVC | Polyvinyl chloride | IPX8 | Ingress protection from water |
|  | Regulator compliance mark |  | Read instruction manual |
|  | Warning | | |



ELECTRICAL SAFETY



WARNING! When using mains-powered tools, basic safety precautions, including the following, should always be followed to reduce risk of fire, electric shock, personal injury and material damage. Read and understand the manual prior to operating this pump.

Save these instructions and other documents supplied with this pump for future reference. The electric motor has been designed for 230V and 240V only. Always check that the power supply corresponds to the voltage on the rating plate.

Note: The supply of 230V and 240V on Einhell pumps are interchangeable for Australia and New Zealand.

Note: The power outlet used for the water pump must be protected by a 30mA residual current device or earth leakage circuit breaker.

If the power outlet is external, ensure that it is weather proof. If the supply cord is damaged, it must be replaced by an electrician or a power tool repairer to avoid a hazard. The water pump has a built-in thermal protection overload switch. The water pump stops if an overload occurs. The motor restarts automatically after it has cooled down.

Using an Extension Lead

Always use an approved extension lead suitable for the power input of this product. Before use, inspect the extension lead for signs of damage, wear and ageing. Replace the extension lead if damaged or defective. Then using an extension lead on a reel, always unwind the lead completely. Use of an extension lead not suitable for the power input of this product or which is damaged or defective may result in a risk of fire and electric shock.



GENERAL POWER TOOL SAFETY WARNINGS



WARNING! Read all safety warnings and all instructions. Failure to follow the warnings and instructions may result in electric shock, fire and/or serious injury.

Save these instructions

1. Work area safety

- Keep work area clean and well lit. Cluttered or dark areas invite accidents.
- Do not operate pumps in explosive atmospheres, such as in the presence of flammable liquids, gases or dust. Pumps create sparks which may ignite the dust or fumes.
- Keep children and bystanders away while operating a pump. Distractions can cause you to lose control.

2. Electrical safety

- Pump plugs must match the outlet. Never modify the plug in any way. Do not use any adapter plugs with earthed (grounded) pumps. Unmodified plugs and matching outlets will reduce risk of electric shock.
- Avoid body contact with earthed or grounded surfaces, such as pipes, radiators, ranges and refrigerators. There is an increased risk of electric shock if your body is earthed or grounded.
- Do not abuse the cord. Never use the cord for carrying, pulling or unplugging the pump. Keep cord away from heat, oil, sharp edges or moving parts. Damaged or entangled cords increase the risk of electric shock.
- When operating a pump, use an extension cord suitable for wet conditions. Use of a cord suitable for wet use reduces the risk of electric shock.
- This pump must be used with a residual current device with rated residual current of 30mA or less. Use of an RCD reduces the risk of electric shock.

3. Personal safety

- Stay alert, watch what you are doing and use common sense when operating a pump. Do not use a pump while you are tired or under the influence of drugs, alcohol or medication. A moment of inattention while operating a pump may result in serious personal injury.
- Avoid accidental starting. Ensure the switch is in the off position before plugging in. Carrying pump with your finger on the switch or plugging in pumps that have the switch on invites accidents.

- Avoid body contact with earthed or grounded surfaces such as pipes, radiators, ranges and refrigerators. There is an increased risk of electric shock if your body is earthed or grounded.
- When operating a pump outdoors, use an extension cord suitable for outdoor use. Use of a cord suitable for outdoor use reduces the risk of electric shock.

4. Pump use and care

- Disconnect the plug from the power source before making any adjustments, changing accessories, or storing pumps. Such preventive safety measures reduce the risk of starting the pump accidentally.
- Maintain pumps. Check for misalignment or binding of moving parts, breakage of parts and any other condition that may affect the pumps operation. If damaged, have the pump repaired before use. Many accidents are caused by poorly maintained pumps.
- Use the pump, and accessories etc., in accordance with these instructions and in the manner intended for the particular type of pump, taking into account the working conditions and the work to be performed. Use of the pump for operations different from intended could result in a hazardous situation.

5. Service

- Have your pump serviced by a qualified repair person using only identical replacement parts. This will ensure that the safety of the pump is maintained.
- If the supply cord is damaged, it must be replaced by the manufacturer, its service agent or similarly qualified persons in order to avoid a hazard.



ADDITIONAL SAFETY WARNINGS FOR PUMPS



WARNING! This product is intended for pumping water in a Home Domestic application. Do not use it for corrosive, abrasive, explosive or dangerous liquids. Fluids other than water will damage the water pump and/or create a fire hazard. Failure to follow all instructions listed below may result in electric shock, fire and/or serious injury.



WARNING! This product is not suitable for use with drinking (potable) water.

This appliance is not intended for use by person (including children) with reduced physical, sensory or mental capabilities, or lack of experience and knowledge, unless they have been given supervision or instruction concerning use of the appliance by a person responsible for their safety.

Children should be supervised to ensure that they do not play with the appliance.

- Ensure the water pump is disconnected from mains power when installing.
- Do not install or operate the water pump in an explosive environment or near flammable material.
- Do not operate the water pump without liquid.
- Do not run the water pump dry.



WARNING! The water pump together with associated pipework operate under pressure. Do not disconnect water pump or pipework until internal pressure has been released. Failure to do this could result in personal injury and damage to property.

- Avoid inserting hands into the inlets/outlets of the water pump while it is connected to power.
- Before using the water pump, always inspect it visually. Do not use the pump if it is cracked and/or damaged. If the water pump is damaged, contact Einhell customer service.
- The water pump has a built-in thermal protection overload switch. The water pump stops if an overload occurs. The motor restarts automatically after it has cooled down.
- The pump must not be used when people are in the water.
- Never work or perform maintenance on the pump without first making sure it has been disconnected from the mains power.
- Pollution of the liquid could occur due to leakage of lubricants

Important:

Avoid inserting hands into the mouth of the pump if it is connected to the mains.

The electrical connection must always be made in a dry area. Make sure that electrical connections are protected from inundations.

Protect the plug and the power cable from heat, oil or sharp edges.

If damaged, The power cable must be replaced by a qualified electrician.

ORDERING REPLACEMENT PARTS

Spare parts can be ordered from the Special Orders Desk at your local Bunnings Warehouse.

For further information, or any parts not listed here, visit

www.einhell.com.au or contact Einhell Customer Service:

Australia 1800 069 486

New Zealand 0508 069 486

E-mail: service.australia@einhell.com

DISPOSAL AND RECYCLING



Power tools that are no longer usable should not be disposed of with household waste but in an environmentally friendly way. Please recycle where facilities exist. Check with your local council authority for recycling advice.



Recycling packaging reduces the need for landfill and raw materials. Reuse of recycled material decreases pollution in the environment. Please recycle packaging where facilities exist. Check with your local council authority for recycling advice.