

Lasertec

LDM120 120M LASER DISTANCE MEASURER



INSTRUCTION MANUAL

SAFETY

Read the following safety instructions before attempting to operate this product.

SAVE ALL WARNINGS AND INSTRUCTIONS FOR FUTURE REFERENCE.

WARNING: Read and understand all instructions.

- Use the laser measurer only with the specified batteries.
- Store the laser measurer out of reach of children and other untrained persons. Lasers are dangerous in the hands of untrained users.
- Due to the electromagnetic radiation interference to other equipment and devices please do not use the laser distance measurer in an airplane or around medical equipment.
- Do not use in a flammable, explosive environment.
- Discarded batteries or devices shall not be processed with household garbage. Please follow related laws and regulations.
- Tool service must be performed only by qualified repair personnel. Repairs, service or maintenance performed by unqualified personnel will void the warranty. Only approved and authorised service technicians can carry out warranty repairs.
- Do not use optical tools such as a telescope or transit to view the laser beam. Serious eye injury could result.

- Do not place the laser in a position which may cause anyone to intentionally or unintentionally stare into the laser beam. Serious eye injury could result.
- Do not position the laser near a reflective surface which may reflect the laser beam toward anyone's eyes. Serious eye injury could result.
- Do not use optical tools to view the laser beam.
- Do not remove or deface warning labels.

 **WARNING: DO NOT DISASSEMBLE THE LASER MEASURER.** There are no user serviceable parts inside. Disassembling the laser will void all warranties on the product. Do not modify the product in any way. Modifying the tool may result in hazardous laser radiation exposure.

CAUTION: Class 2 Laser Product

- Never look into the laser beam directly and intentionally.
- Do not use optical tools to view the laser beam.
- Do not let children come in contact with the laser measurer.

ITEM CHECKLIST

Please ensure the following items are included with your laser distance measurer. If anything is missing please contact your retailer.



Lasertec LDM120

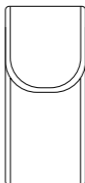

Carry pouch



Carry strap



USB cable



Rechargeable
batteries

PRODUCT OVERVIEW

LASER MEASURER FRONT

Laser emitter

LCD screen

Control panel

USB connection port

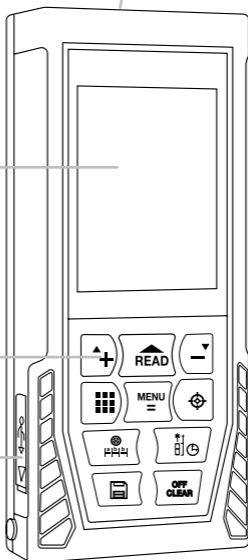

LASER MEASURER BACK

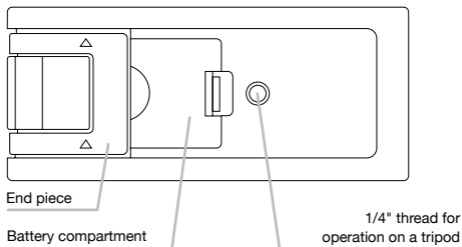

- i** Unfold the end piece to access the battery compartment.

LASER MEASURER BOTTOM

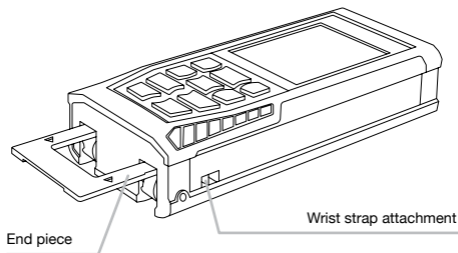

CONTROL PANEL

Subtraction / scroll down

Camera

Read (laser emission on)

Addition / scroll up

Multi-function

Digital bubble vial /
staking out

Data storage

Menu / equal

Power off / clear

Benchmark / timer

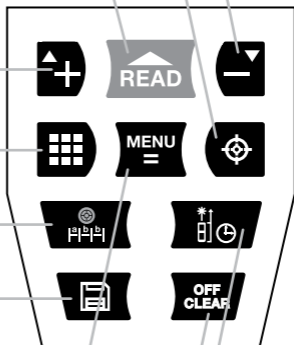

DISPLAY SCREEN

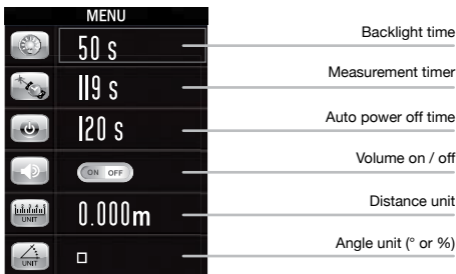
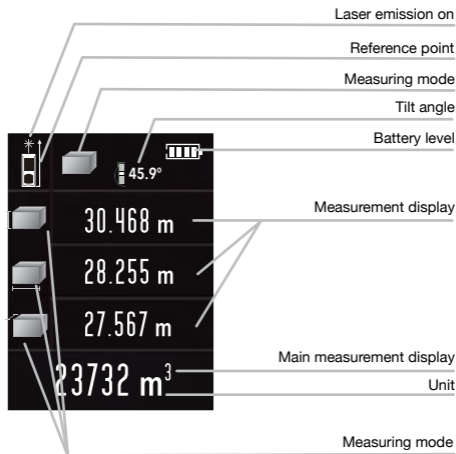

USING YOUR LASER MEASURER

POWER SUPPLY

- The instrument is supplied with three 1.2v AAA Ni-Mh rechargeable batteries. To replace batteries, unfold the endpiece and remove the battery door at the back of the device. Place batteries according to polarity and replace battery door.
- The batteries can be charged via the USB cable. Place the micro USB end into the USB connection port. Insert the other end into a USB charging device.



The USB port is for charging the batteries only and does not act as a data connection to devices such as computers.

- The battery level icon will flash while the battery is charging. The battery level icon will appear solid green when the battery is fully charged.
- For infrequent use, please take out the battery to avoid corrosion to the body of the device.



WARNING: Do not charge alkaline batteries. Charging alkaline batteries may cause damage to the device, and may leak, explode or cause fire!

OPERATION

On/off

- a) Press and hold the read button to turn the laser distance measurer on.
- b) Press and hold the off / clear button for 3 seconds to turn the unit off. The device will shut off automatically after 150 seconds without use. (See page 19 to adjust the automatic shut off timer.)

Unit setting

- The unit default setting is 0.000m. To reset the current unit of measurement press the menu / equal button.
- Press the subtraction / scroll down button to scroll down to the distance unit setting.
- Press the menu / equal button to adjust the units. Press the addition / scroll up button or the subtraction / scroll down button to scroll through the unit options.
- Press the menu / equal button to select the unit.
- Press the off / clear button to return to the measurement screen.

OPTIONAL UNITS		
Length	Area	Volume
0.000m	0.000m ²	0.000m ³
0.00m	0.00m ²	0.00m ³
0.0in0	0.00ft ²	0.00ft ³
0.00ft0	0.00ft ²	0.00ft ³
0 1/16 in	0.00ft ²	0.00ft ³
0'00' 1/16"	0.00ft ²	0.00ft ³
0.000 米 (metre)	0.000 米 ² (metre)	0.000 米 ³ (metre)
0.00 米 (metre)	0.00 米 ² (metre)	0.00 米 ³ (metre)

Reference point setting

To cycle between the benchmark reference points press the benchmark / timer button. There are four reference points: top, middle, bottom and end piece.



MEASUREMENT

Single measurement

- a) Press the read button. The laser will be emitted.
- b) Re-press the read button for a single distance measurement. Results will be displayed on the main measurement display.
- c) The previous three measurements will also be displayed above the main measurement display.



Continuous measurement

- a) Press and hold the read button. Minimum and maximum results will be displayed on the display screen.
- b) Press the read button or off / clear button to exit continuous measurement.

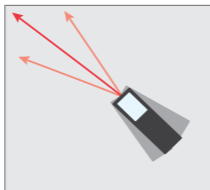

Area measurement

- a) Press the multi-function button. Two rectangles will appear on the display screen.
- b) Press the read button to measure the first edge (width).
- c) Press the read button to measure the second edge (length).
- d) Area will be calculated automatically with results shown on the display screen.
- e) Press the off / clear button to clear measurement.

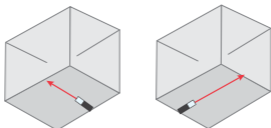

Volume measurement

- a) Press the multi-function button twice. Three rectangles will appear on the display screen.
- b) Press the read button to measure the first edge (height).
- c) Press the read button to measure the second edge (length).
- d) Press the read button to measure the third edge (width).
- e) Volume will be calculated automatically with results shown on the display screen.
- f) Press the off / clear button to clear measurement.

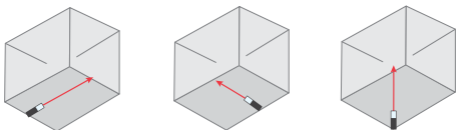

Pythagoras measurement

To calculate the unilateral distance of a triangle pythagorean mode can be used. When taking measurements of the triangle, ensure the length of the right side is shorter than the length of the hypotenuse. If not, the instrument will display an error signal.

To ensure the accuracy of measurement, take measurements from the same starting point of the first order hypotenuse. Then follow with the measurement of the right side. Please follow the instructions according to the method required. (See diagrams on pg 12-15 to determine the appropriate method).

1. Calculate two sides of a right angle triangle

Press the multi-function button three times to enter pythagorean mode. Follow the instructions displayed on the screen as follows:

- Press the read button to measure the length (a) of the hypotenuse and tilt angle.
- Length (x) will be calculated automatically with results shown on the display screen.

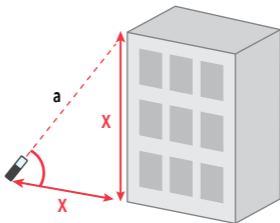

2. Calculate the side of a right angle triangle

Press the multi-function button four times to enter pythagorean mode.

Follow the instructions displayed on the screen as follows:

- Press the read button to measure the length (a) of the hypotenuse.
- Press the read button to measure the length (b) of the rectangular side.
- Length (x) will be calculated automatically with results shown on the display screen.

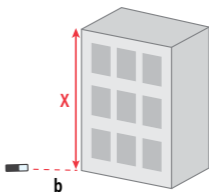
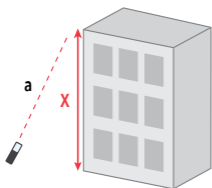

3. Calculate the hypotenuse of a right angle triangle

Press the multi-function button five times to enter pythagorean mode.

Follow the instructions displayed on the screen as follows:

- Press the read button to measure the length (a) of the rectangular side.
- Press the read button to measure the length (b) of the next rectangular side.
- Length (x) of the hypotenuse will be calculated automatically with results shown on the display screen.

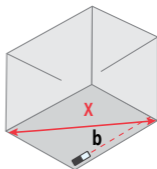
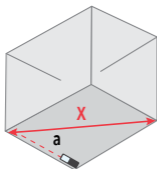

4. Calculate the third side of a triangle

Press the multi-function button six times to enter pythagorean mode.

Follow the instructions displayed on the screen as follows:

- Press the read button to measure the length (a).
- Press the read button to measure the length (b).
- Press the read button to measure the length (c).
- Length (x) of the vertical side will be calculated automatically with results shown on the display screen.

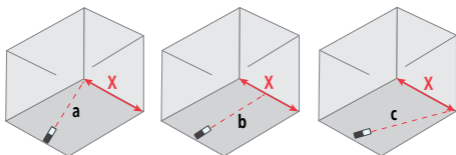

5. Calculate partial length of a right angle triangle

Press the multi-function button seven times to enter pythagorean mode. Follow the instructions displayed on the screen as follows:

- Press the read button to measure the length (a) of the hypotenuse.
- Press the read button to measure the length (b) of the second hypotenuse.
- Press the read button to measure the length (c) of the rectangular side.
- Length (x) of the vertical side will be calculated automatically with results shown on the display screen.

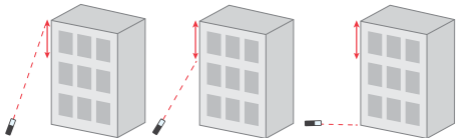

6. Calculate the area of an irregular triangle

Press the multi-function button eight times to enter pythagorean mode.

Follow the instructions displayed on the screen as follows:

- Press the read button to measure the length (a).
- Press the read button to measure the length (b).
- Press the read button to measure the length (c).
- Area (x) will be calculated automatically with results shown on the display screen.

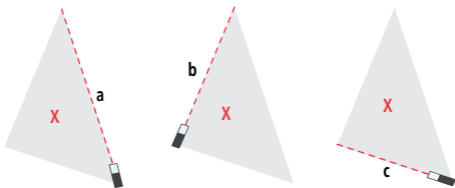

OTHER FUNCTIONS

Delayed measurement (timer)

- Press and hold the benchmark / timer button.
- Press the addition / scroll up button or the subtraction / scroll down button to adjust the time in seconds. (Minimum 5 seconds, maximum 60 seconds).
- Once the time has been set, press the read button.

Adding and subtracting single measurement

Addition

- a)** Take the first reading by pressing the read button.
- b)** Press the addition / scroll up button. A “+” symbol will appear on the display screen.
- c)** Take the second reading by pressing the read button. The values will be added automatically with the results shown on the display screen.

Subtraction

- a)** Take the first reading by pressing the read button.
- b)** Press the subtraction / scroll down button. A “-” symbol will appear on the display screen.
- c)** Take the second reading by pressing the read button. The values will be subtracted automatically with the results shown on the display screen.
- d)** Press off / clear button to exit addition or subtraction mode.



To clear the previous measurement, press the off / clear button.

Adding and subtracting area measurement

- a)** Take the area measurement as described in the Area Measurement section (pg 11) .
- b)** Press the addition / scroll up button or the subtraction / scroll down button. A “+” or “-” symbol will appear on the display screen.
- c)** Take the second area measurement as described in the Area Measurement section (pg 11) .
- d)** Press the menu / equal button. The values will be calculated automatically with the results shown on the display screen.
- e)** Repeat step two and three to add or subtract more area measurements.

Adding and subtracting volume measurement

a) Take the volume measurement as described in the Volume Measurement section (pg 11) .

b) Press the addition / scroll up button or the subtraction / scroll down button.

A “+” or “-” symbol will appear on the display screen.

c) Take the second volume measurement as described in the Volume Measurement section (pg 11) .

d) Press the menu / equal button. The values will be calculated automatically with the results shown on the display screen.

e) Repeat step two and three to add or subtract more volume measurements.

Staking-out function

The staking-out function allows the user to enter a value into the unit. The unit setting will then guide the user into finding the exact reference point.

a) Press and hold the staking out / digital bubble vial button to enter staking-out mode.

b) Press the addition / scroll up button or the subtraction / scroll down button to adjust the setting of a. Press the read button to confirm the unit setting.

c) Press the addition / scroll up button or the subtraction / scroll down button to adjust the setting of b. Press the read button to confirm the unit setting.

d) The unit will display an arrow pointing forwards or backwards, depending on the location of the user. Move forward or back until the unit shows the centered symbol.



move back



move forward



centered

Multi-directional electronic bubble vial

a) Press and hold the *staking out / digital bubble vial* button.

b) Press the *off / clear* button to exit.

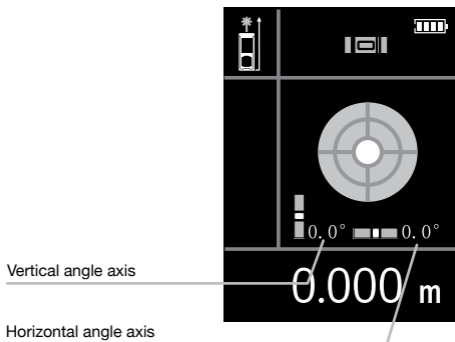

Camera

The camera function assists with targeting the laser diode in long range measurements and in bright sunlight.

Single measurement with camera

a) Press the *camera* button to view the target area through the camera.

b) Target the desired area and press the *read* button. Press the *camera* button to exit.

Area / volume /pythagoras measurement with camera

a) The camera can also be used during area, volume or pythagoras measurement. Press the *multi-function* button to enter the desired measurement mode.

b) Press the *camera* button to view the target area through the camera.

c) Target the desired area and press the *read* button. Press the *camera* button to return. Repeat until all measurements have been taken.

Storage and browsing

Save a reading

Press and hold the *data storage* button. The data will automatically be stored in the memory of the unit.

View storage

To view stored measurements, press the *data storage* button. Press the *addition / scroll up* button or the *subtraction / scroll down* button to browse through the data.









Remove records

To remove a record, press the *power off / clear* button. To remove all stored data press and hold the *power off / clear* button.

MENU OPTIONS

Navigating the menu

- Press the menu / equal button to enter the menu.
- Press the addition / scroll up button or the subtraction / scroll down button to scroll through the menu settings.
- Press the menu / equal button to adjust the setting. Press the addition / scroll up button or the subtraction / scroll down button to scroll through the options.
- Press the menu / equal button or the data storage button to select and save the setting.
- Press the off / clear button to return to the measurement screen.

Menu Item	Description	Optional Settings
	Backlight	5 seconds - 60 seconds
	Laser active timer	20 seconds - 120 seconds
	Auto power off	100 seconds - 300 seconds
	Sound	On / Off
	Unit setting	Metres / feet / inches
	Angle unit	Degree (°) / slope (%)
	Calibration	-0.009m to +0.009m
	Bluetooth	On / Off

 Adjusting the calibration setting may affect the precision of the device.

TROUBLE SHOOTING

Error code	Cause & solution
ERR1	Signal is too weak. Measure target locations that have stronger reflecting surfaces.
ERR2	Signal is too strong. Measure target locations that have weaker reflecting surfaces.
ERR3	Battery voltage too low. Charge or replace batteries.
ERR4	Memory damage. Please contact the supplier.
ERR5	Improper measurement in pythagorean mode. Re-measure and ensure the correct pythagorean method is used. Please refer to pg 12-15.
ERR6	Exceed the measuring range Measure within the measuring range of the device.
ERR7	Camera fail Please contact the supplier.
ERR8	Tilt fail Please contact the supplier.

CARE AND MAINTENANCE

- Inaccurate measurement results may occur in harsh environments such as strong sunlight, excessive temperature fluctuations, weak reflective surfaces or low battery.
- Whenever possible, store the instrument in a cool, dry place. Do not store in high temperatures or strong humidity for long periods of time.

- Store in the carry pouch supplied in a cool, dry place.
- Remove the batteries before storing the device for long periods of time without use.
- To remove dust, clean the instrument with a damp, soft cloth.

WARRANTY

The Lasertec LDM120 comes with a 3 year manufacturers warranty.

AUSTRALIA

"Our goods come with guarantees that cannot be excluded under the Australian Consumer Law. You are entitled to a replacement or refund for a major failure and for compensation for any other reasonably foreseeable loss or damage. You are also entitled to have the goods repaired or replaced if the goods fail to be of acceptable quality and the failure does not amount to a major failure."

For more information please visit consumerlaw.gov.au

NEW ZEALAND

For more information please visit consumerprotection.govt.nz

CUSTOMER SUPPORT

To assist you with any queries or technical questions please contact customer support

Australia: 1300 658 338

New Zealand: 0800 367 527

The Bluetooth® word mark and logos are registered trademarks owned by the Bluetooth SIG, Inc. and any use of such marks by Spot-on Laser and Tool Company is under license. Other trademarks and trade names are those of their respective owners.

Apple and the Apple logo are trademarks of Apple Inc., registered in the U.S. and other countries. App store is a service mark of Apple Inc.

Android, Google Play and the Google Play logo are trademarks of Google Inc.

SPECIFICATIONS

Specifications	Lasertec LDM120
Product code	91425
Accuracy	±1mm
Minimum measurement range (top reference point)	0.05m
Maximum measurement range	120m
Minimum unit displayed	0.05mm
Measurement unit options	m/in/ft
Continuous measurement function	yes
Area measurement function	yes
Volume measurement function	yes
Add and subtract measurement function	yes
Max storage	100 units
Automatic backlight	yes
Buttons sound	yes
Laser class	2 Red
Laser type	635nm, <1mW
Automatic laser cut off	20s - 120s
Automatic shutdown	100s - 300s
Storage temperature	-20° - 60° C
Working temperature	0° - 40° C
Storage humidity	RH85%
Battery	3x 1.2v AAA Ni-Mh 800mAh
Weight (Inc battery)	158g
Dimensions	130 x 55 x 28mm



www.spoton.com.au