



## HERITAGE RANGE SQUARE PLANTER

<b>SM</b> :	400mm (L)	400mm (W)	400mm (H)
<b>MED</b> :	600mm (L)	600mm (W)	500mm (H)
<b>LG</b> :	700mm (L)	700mm (W)	600mm (H)

### IMPORTANT

#### ASSEMBLE THIS PLANTER ON A FLAT LEVEL SURFACE

This heritage timber bed is manufactured from the highest quality cypress heartwood. To prevent discolouration over time it is recommended that once assembled the external surfaces are coated with a quality natural oil or stain.

Before filling the bed with soil, ensure it is square and level.

Be aware that this timber product may splinter so it is recommended that protective gloves are worn during assembly.

### KIT CONTENTS

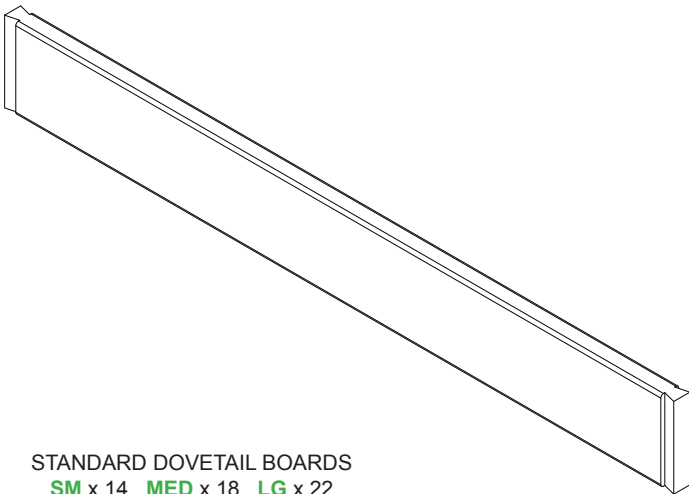

STANDARD DOVETAIL BOARDS  
**SM** x 14 **MED** x 18 **LG** x 22

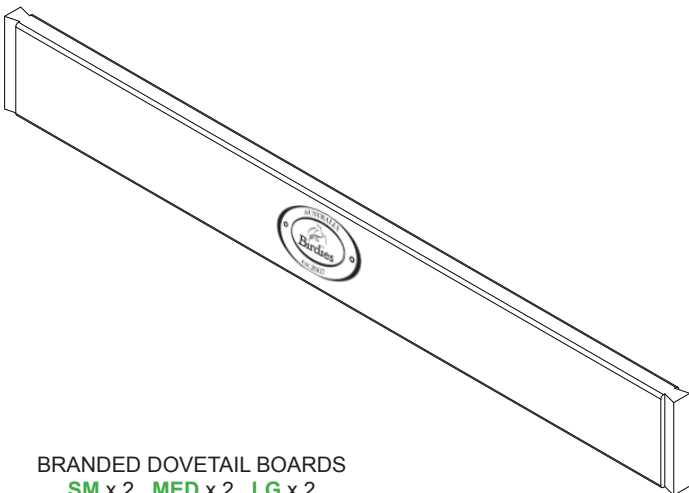

BRANDED DOVETAIL BOARDS  
**SM** x 2 **MED** x 2 **LG** x 2

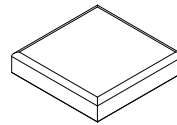

CAPS x 4



HARDWOOD DOWELS x 4

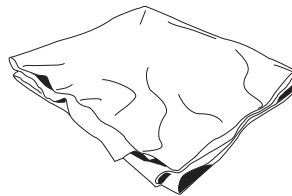

GEOTEXTILE FABRIC x 1

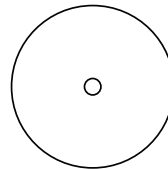

STAINLESS STEEL  
SUPPORT DISCS x 4



WOOD  
SCREWS x 4

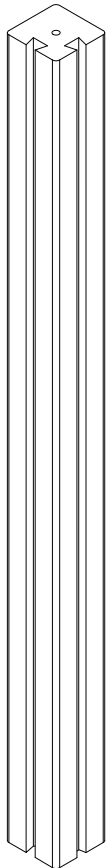

DOVETAIL POSTS x 4

# ASSEMBLY

## STAGE 01

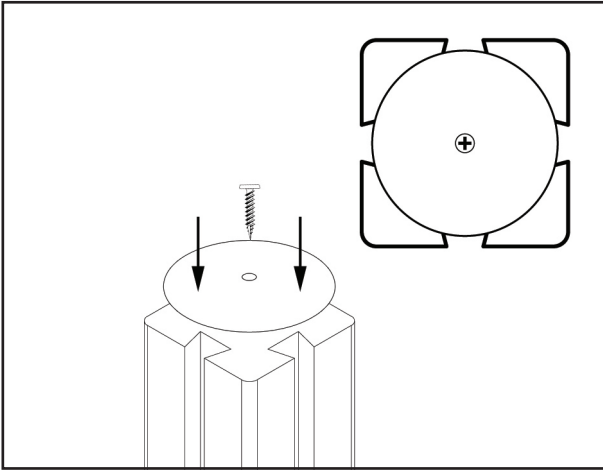

Screw the disc to the bottom of the post as shown. Note the larger 8mm hole is the top of the post. The disc is not required on hard level surfaces such as concrete, deck or pavers

## STAGE 02

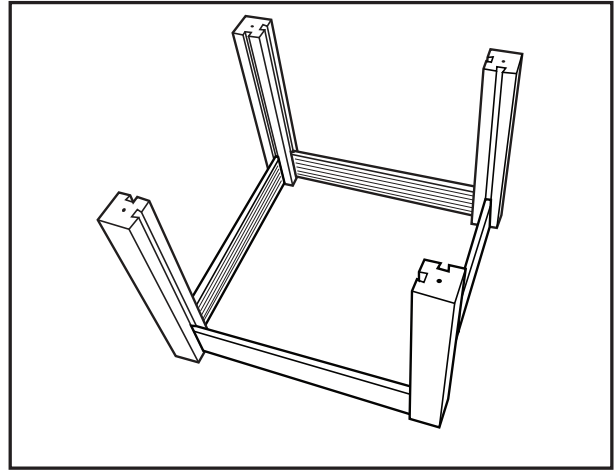

Ensuring the 8mm hole is on the top & the grooved (reeded) side of the timber boards is facing inwards slide in 4 standard boards as above.

## STAGE 03

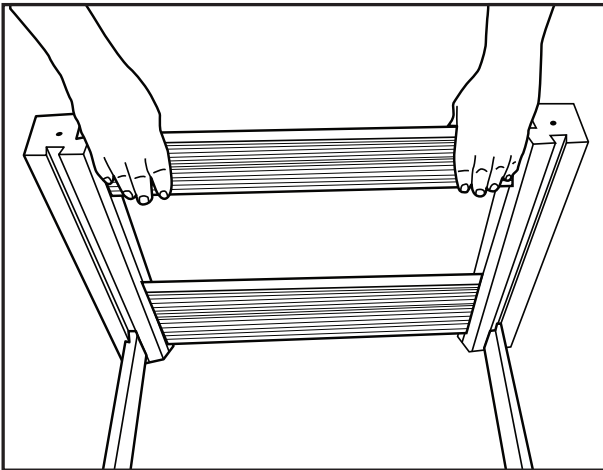

Slide in the remaining boards ensuring the branded board is on top. **Please note:** Hold the boards equally allowing the weight of the board to find the correct position.

## STAGE 04

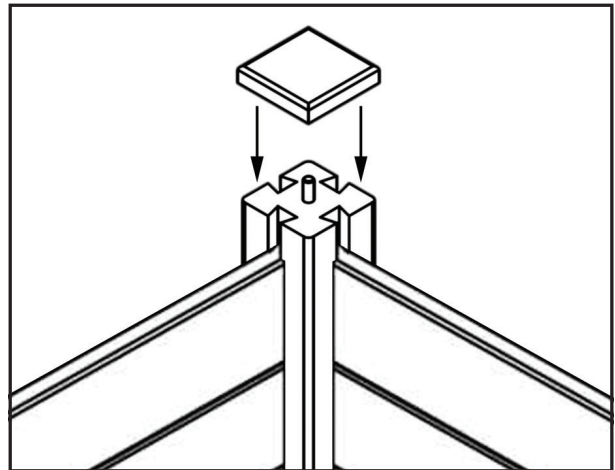

Insert the 4 hardwood dowels into the holes on the top of the posts by hand and then place 4 caps over these dowels. Push down to secure. **Optional:** Wood glue can be used to fix the cap in place.

## STAGE 05

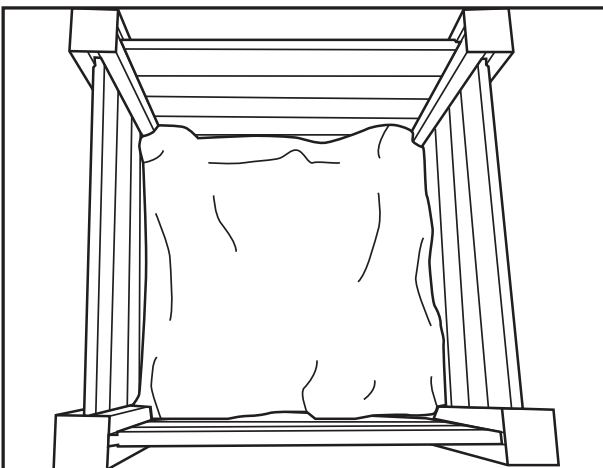

Lay the black geotextile fabric in evenly. Allow excess fabric to lay up the walls. Start filling by placing the soil into each corner of the planter whilst holding the fabric up, this will prevent soil from washing away once filled.

## STAGE 06

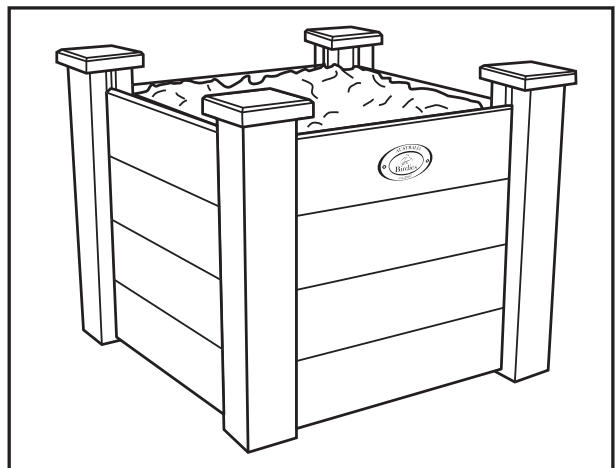

Completed Planter