

# 18V Brushless 165mm Circular Saw



DHS680

**LXT**  
LITHIUM-ION **BL**  
MOTOR

# Product Objectives

**Makita**

- Expand our line up of brushless tools
- Lead the market with innovation like “Automatic Torque Drive”
- Deliver a market leading 165mm Circular Saw



# Features and Benefits

**Makita**



# Specifications

**Makita**



Blade Diameter	165mm
Cutting Capacity: at 90°	57mm
at 45°	41mm
at 50°	37mm
No Load Speed	5,000rpm
Bevel Capacity	0-50 degrees
Overall Length	350mm
Net Weight	3.3kg

# Advantages

**Makita**

## Efficiency



Automatic Torque Drive - Increases motor torque according to load conditions

## Innovation



Battery Fuel Gauge, Torque Drive and Overload highlighted with LED indicators

## Performance

**BL**  
**MOTOR**

Brushless DC motor. 30% better run time than DSS610

## Precision

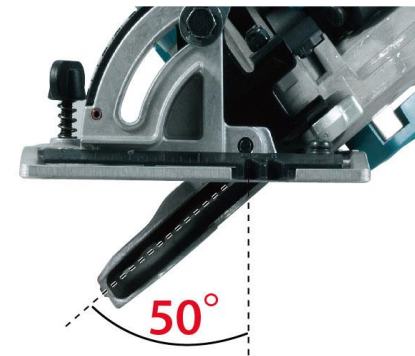

Magnesium base with 45° and 50° bevel capacity

## Automatic Torque Drive

Automatically changes the cutting speed according to load conditions for optimum operation

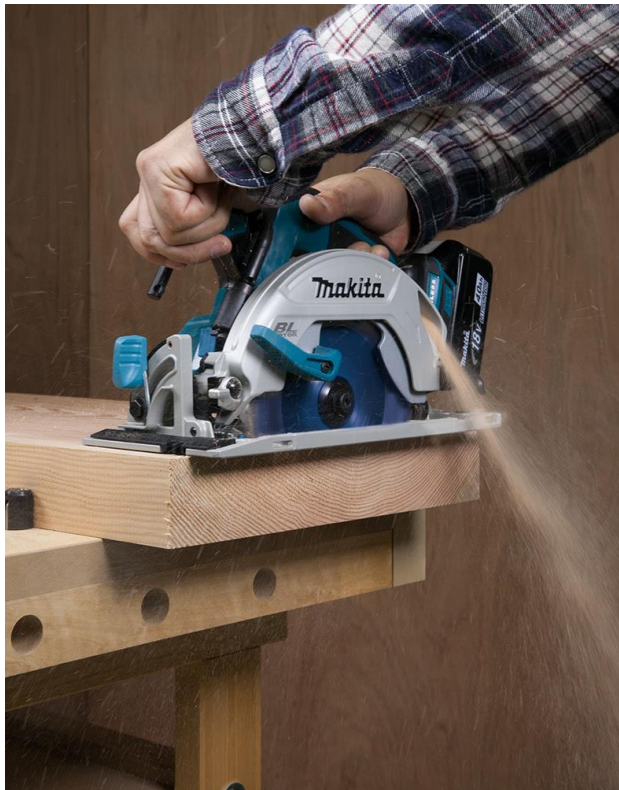

## Indication of Automatic Torque Drive

(active during operation)

- All LEDs off: high-speed rotation mode
- 1 solid green LED: high torque mode



## Indication of Overload

All LED's start blinking when Overload Protection has been activated to stop the motor



# Advantages

**Makita**

## Magnesium Base

Bevel Cuts to 45° and up to 50°

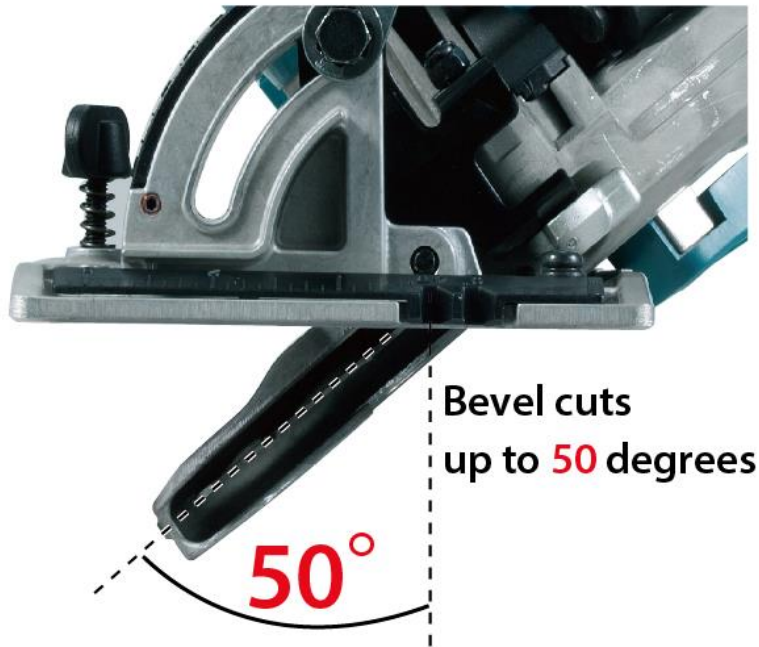

## Lock Off Lever

Large lock off lever easy-to-operate even with a gloved hand

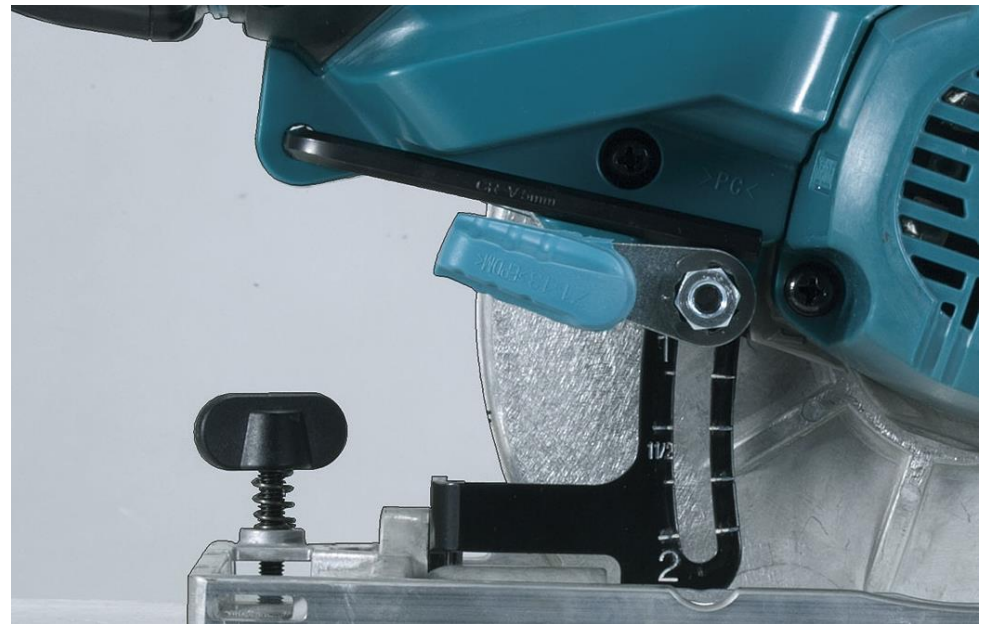

# Advantages

**Makita**

## Compact and Lightweight design

- Achieved by a downsized motor and better placement of parts
- Using durable but light magnesium die-cast for Base, Blade Case and Safety Cover

**DSS610**  
**3.5kg**

**DHS680**  
**3.3kg**

Weighs 200g less than DSS610

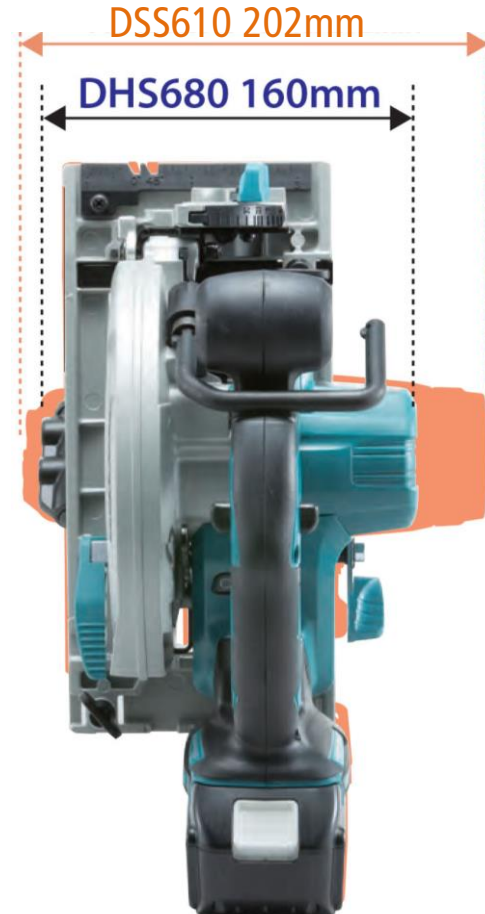

42mm less overall length than DSS610



# Advantages

**Makita**

## Compatibility

Compatible with Li-Ion batteries from 1.5Ah up to 5.0Ah with fast charging\* and longer run times \*DC18RC / DC18RD



## Fast Charging



**15min**  
Charge Time  
1.5Ah BL1815N



**22min**  
Charge Time  
3.0Ah BL1830



**36min**  
Charge Time  
4.0Ah BL1840



**45min**  
Charge Time  
5.0Ah BL1850

# Advantages

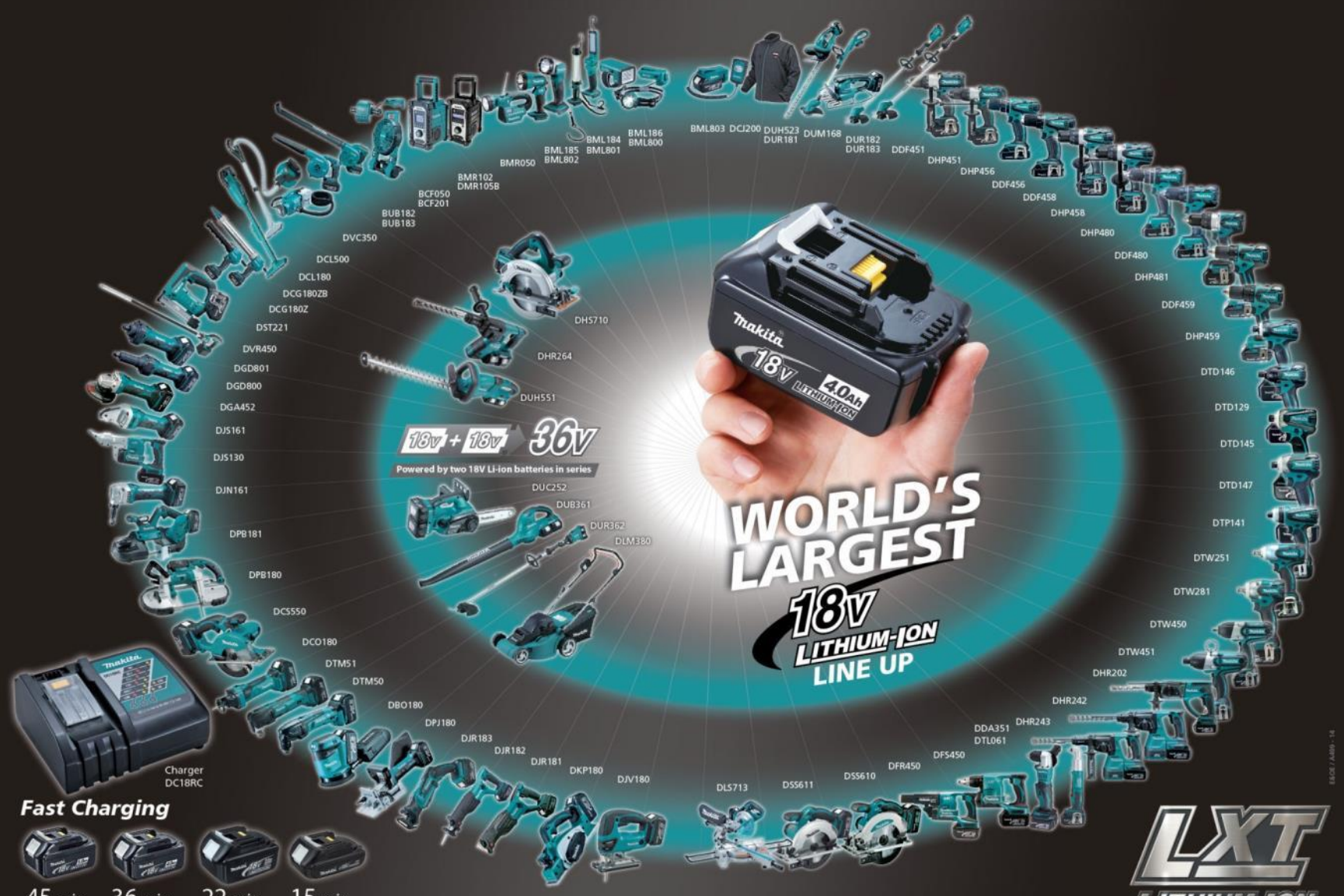

**18v + 18v = 36v**  
 Powered by two 18V Li-ion batteries in series

**WORLD'S LARGEST  
 18V LITHIUM-ION  
 LINE UP**



Charger  
DC18RC

### Fast Charging



45 min 5.0Ah BL1850  
 36 min 4.0Ah BL1840  
 22 min 3.0Ah BL1830  
 15 min 1.5Ah BL1815N



8826 / A-000 - 14

# Accessories



## Standard Equipment

	B-15073	BlueMak Saw Blade 165mm x 24T
	164095-8	Guide Rule
	783217-7	Hex Wrench

## Optional Accessories

	BL1815N BL1830 BL1840 BL1850	1.5Ah Battery 3.0Ah Battery 4.0Ah Battery 5.0Ah Battery
	DC18RC DC18SD	Fast Charger Standard Charger

## Optional Accessories

	B-15089	BlueMak Saw Blade 165mm x 40T
	B-20971	165mm x 4T PCD Saw Blades
	B-37580	165mm x 52T Laminate Saw Blade
	196961-1	Dust Nozzle
	194368-5	1,400mm Aluminium Track
	195839-5	Track Adaptor