

**FRONT:** 1.52m  
**SIDE:** 3.0m  
**HEIGHT:** 1.80m

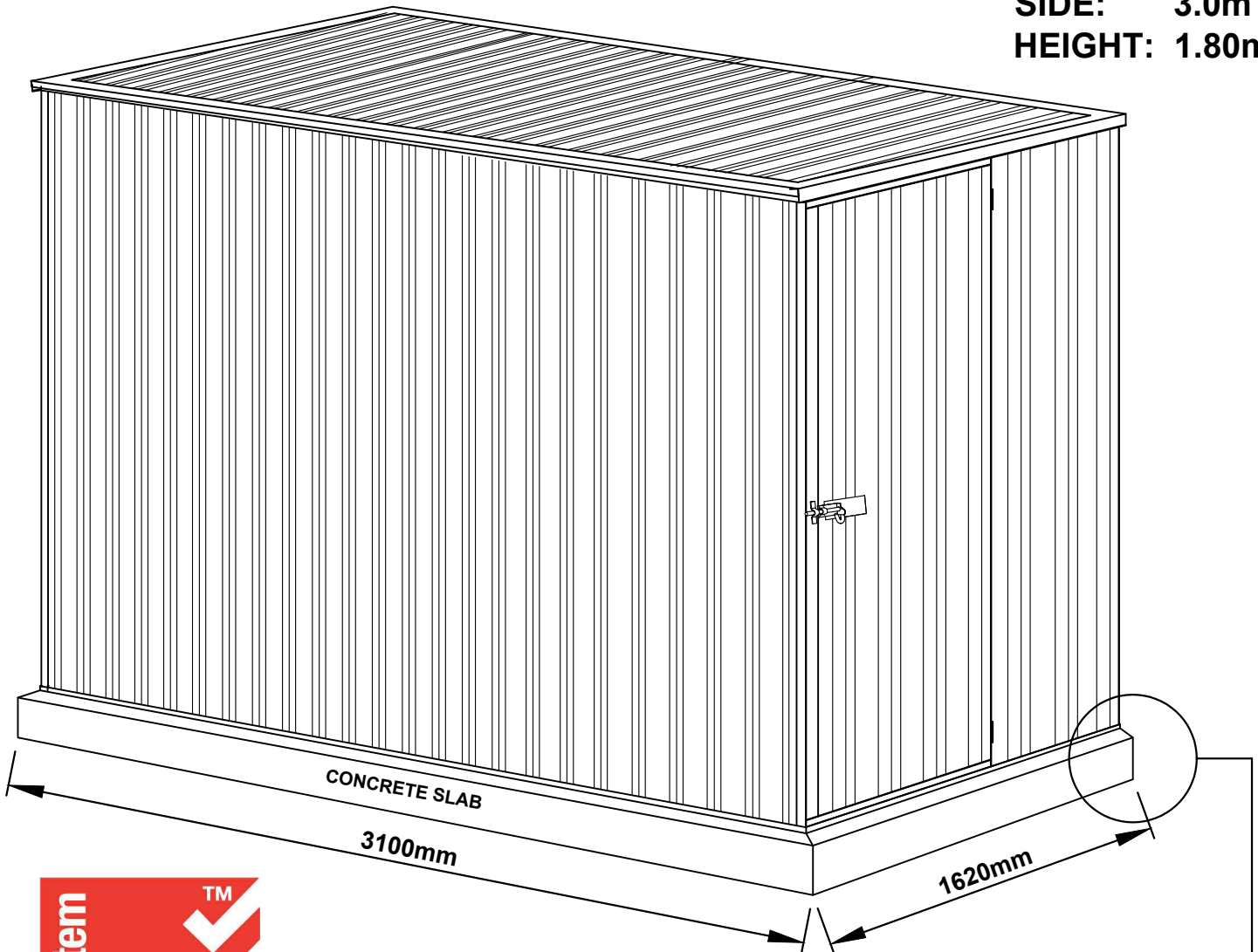

Quality  
ISO 9001



We thank you for choosing an Australian made shed. For further assistance please visit our detailed instructional video library at [Http://www.abscosheds.com.au/watch-videos](http://www.abscosheds.com.au/watch-videos)

At ABSCO Industries we are always looking to be number ONE, so please let us know what you think of our instructions. Feedback makes us better.  
[feedback@abscos.com.au](mailto:feedback@abscos.com.au)

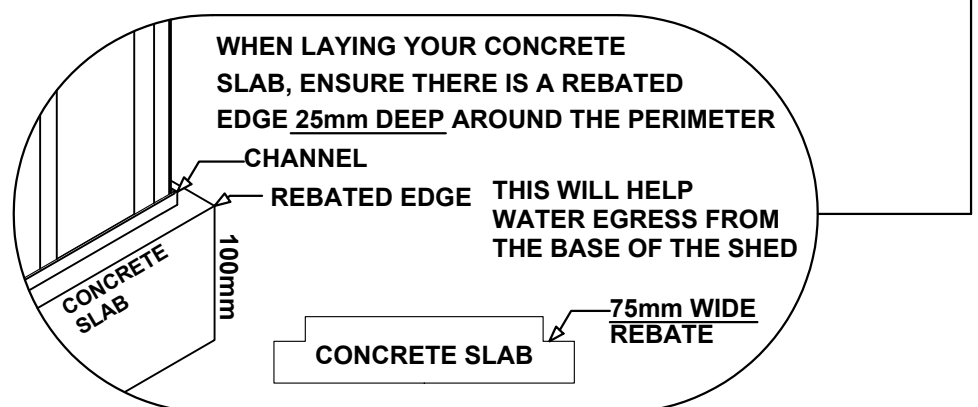



## GENERAL INSTRUCTIONS

- Before commencing any assembly, read through these instructions in detail to gain a thorough understanding of assembly methods and associated details.
- Unpack the carton and carefully identify and check off all the parts against the parts described and illustrated on pages three and four.

## SITE PREPARATION

- The site for the shed must be level. An uneven surface may result in misalignment of parts.
- It is recommended that the shed be set on a 100mm concrete slab and anchored down appropriately (refer to last page for details). A flat slab with a chamfered edge can be used but will not result in optimum results.
- Anchor sets are not supplied as standard items with this product. As some customers wish to use their own anchoring systems

## TOOLS REQUIRED





## A NOTE ON SAFETY

- Some parts may have sharp edges. It is advisable to wear gloves when handling these items and safety glasses if drilling holes. Sensible shoes are highly recommended.
- Do not erect your shed in windy conditions, ensure that the shed is securely anchored to a solid foundation immediately after construction is completed.
- It is highly recommended to erect the shed with two or more people.





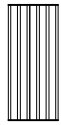
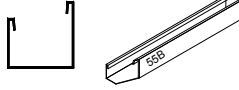
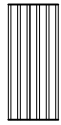
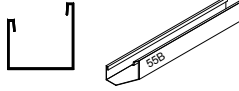

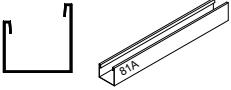
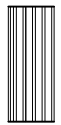
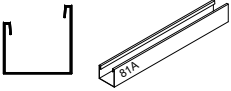
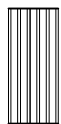
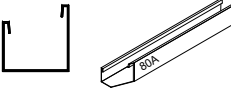
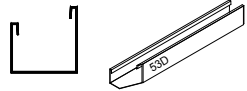
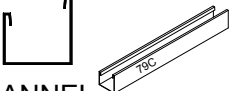
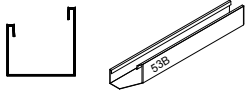
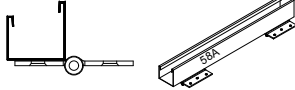
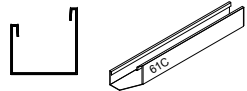
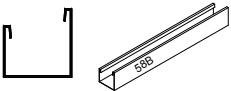
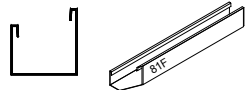
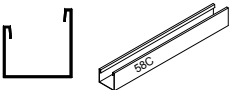
### COMPONENTS PACKING LIST - CHECK OFF ALL COMPONENTS

QTY	COMPONENT DESCRIPTION	PART No.	CHECK	QTY	COMPONENT DESCRIPTION	PART No.	CHECK
5	 STEEL SHEET 1785mm X 773mm	30A		2	 CHANNEL L = 1496.5mm	55BL	
5	 STEEL SHEET 1785mm X 773mm	31A		2	 CHANNEL L = 1496.5mm	55BR	
4	 STEEL SHEET 1592mm X 773mm	43A		4	 CHANNEL L = 1496.5mm	81AL	
1	 STEEL SHEET 1785mm X 711mm	34A		4	 CHANNEL L = 1496.5mm	81AR	
1	 STEEL SHEET 1725mm X 773mm	B		1	 CHANNEL L = 1785mm	80A	
1	 CHANNEL L = 1513mm	53D		1	 CHANNEL L = 783mm	79C	
1	 CHANNEL L = 1513mm	53B		1	 CHANNEL WITH HINGES L = 1725mm	58A	
1	 CHANNEL L = 1513mm	61C		1	 CHANNEL L = 1725mm	58B	
1	 CHANNEL L = 1513mm	81F		2	 CHANNEL L = 773mm	58C	

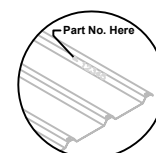
**ALL SHEETS HAVE PART NO.S LOCATED ON LOWER RIGHT OR UPPER LEFT CORNER OF COLORED SIDE AS SHOWN**



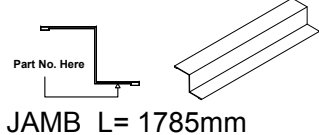
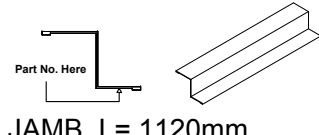
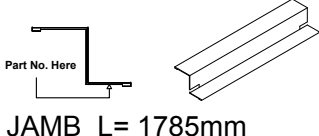

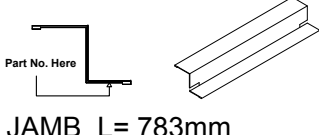
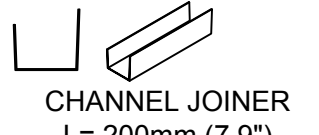
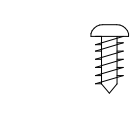
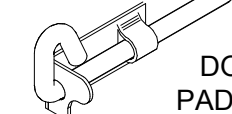
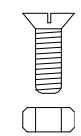
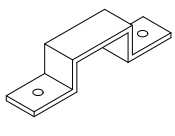
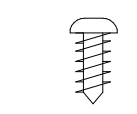
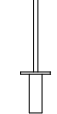
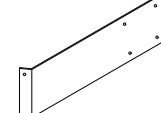
**COMPONENTS PACKING LIST - (CONT.) CHECK OFF ALL COMPONENTS**

QTY	COMPONENT DESCRIPTION	PART No.	CHECK	QTY	COMPONENT DESCRIPTION	PART No.	CHECK
1	 Part No. Here JAMB L= 1785mm	89A		2	 Part No. Here JAMB L= 1120mm	91A	
1	 Part No. Here JAMB L= 1785mm	89B		2	 LIP TRIM L= 1592mm	88A	
1	 Part No. Here JAMB L= 783mm	90C		6	 CHANNEL JOINER L= 200mm (7.9")	CSJ	
<b>CONTENTS OF FITTINGS PACKET</b>							
220	 SELF TAPPING SCREWS 10mm			1	 DOOR PADBOLT	22A	
6	 4mm CSK SCREW & NUT SECURE HINGES TO DOOR			1	 DOOR PADBOLT HASP		
6	 SELF TAPPING SCREWS 20mm			6	 3mm POP RIVETS SECURE HINGES TO DOOR (ALTERNATIVE FIXING METHOD)		
1	ASSEMBLY INSTRUCTIONS			1	 DOOR STRAP L: 165mm	12A	

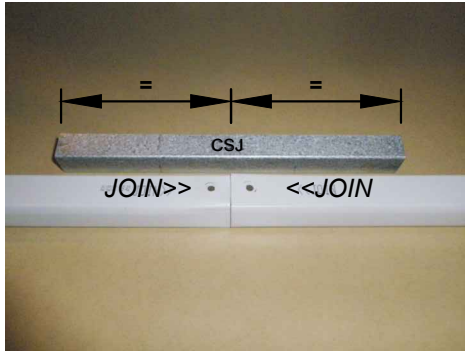

### INSTRUCTIONS FOR JOINING SPLICED CHANNELS

NOTE: THE TEXT MARKED ON ALL PARTS MUST BE SHOWN ON THE SAME SIDE AS EACH OTHER.



#### STEP 1.

Position the channels and the CSJ so the center of the CSJ is in line with the end of each channel to be joined together.

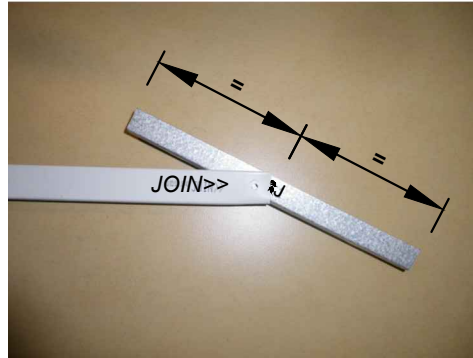

#### STEP 2.

Join the first channel to the CSJ by inserting the center of the CSJ (on an angle) to the end of the channel where the JOIN>> text is marked. Push down one side of the CSJ until you hear a 'click'.

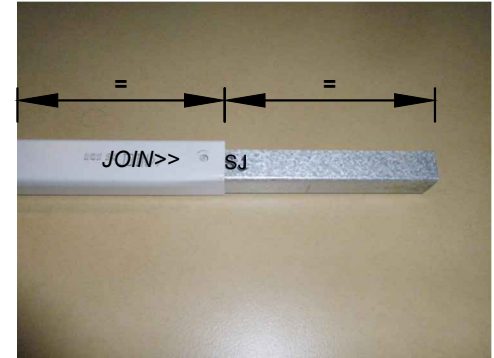

#### STEP 3.

Join the second channel to the CSJ by positioning the <<JOIN end of the channel at the center of the CSJ (on an angle). Push the CSJ into the channel until you here a 'click'.

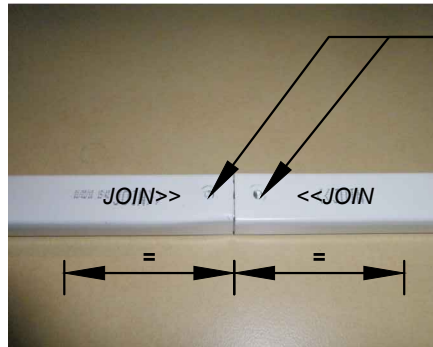

#### FINISHED CHANNEL

The joined channels should now look like the picture above with the CSJ positioned equally inside of the joined channels.

DRILL 4mm (0.16") x 3mm (0.12") (2 PER A SIDE) HOLES TO SECURE SECTIONS TOGETHER. (THESE SCREWS MAY HAVE TO BE TEMPORARILY REMOVED AND REPLACED DURING LATER ASSEMBLY)

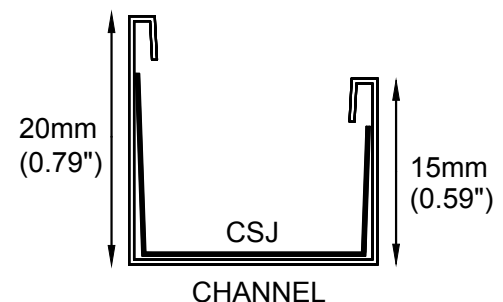
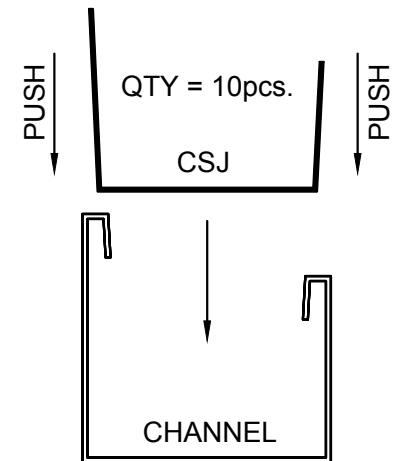
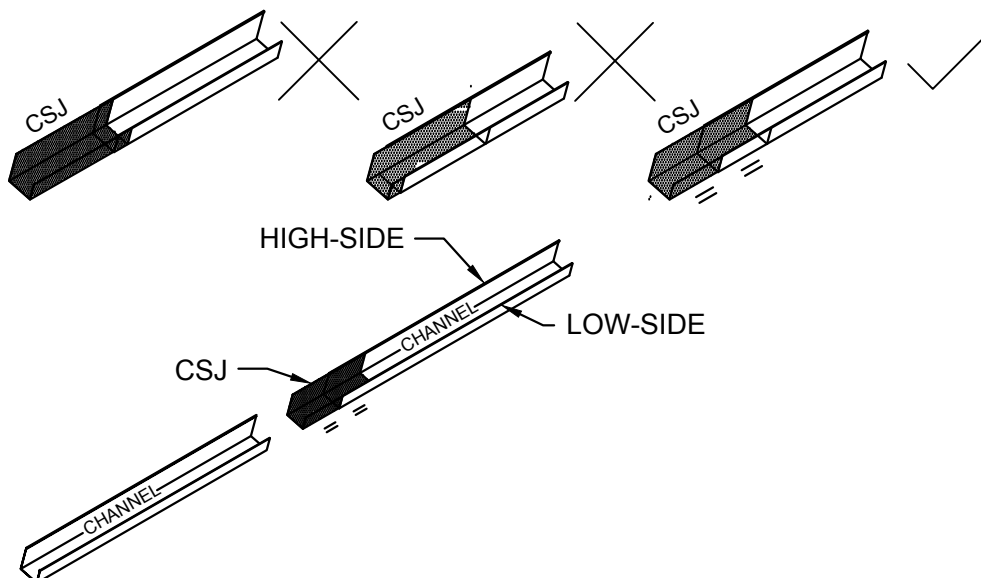



**STEP 1. PRE-ASSEMBLY OF SPLICED CHANNELS**

**NOTE:** JOIN TOGETHER 12 X CHANNEL SECTIONS USING 6 X CHANNEL JOINERS (PART CSJ)

**NOTE:** SOME CHANNELS HAVE HOLES IN THEM - YOU WILL NEED TO RE-DRILL HOLES ON ANY CHANNEL WHERE THE CSJ JOINING CHANNEL COVERS HOLES ON THE CHANNELS YOU ARE CONNECTING

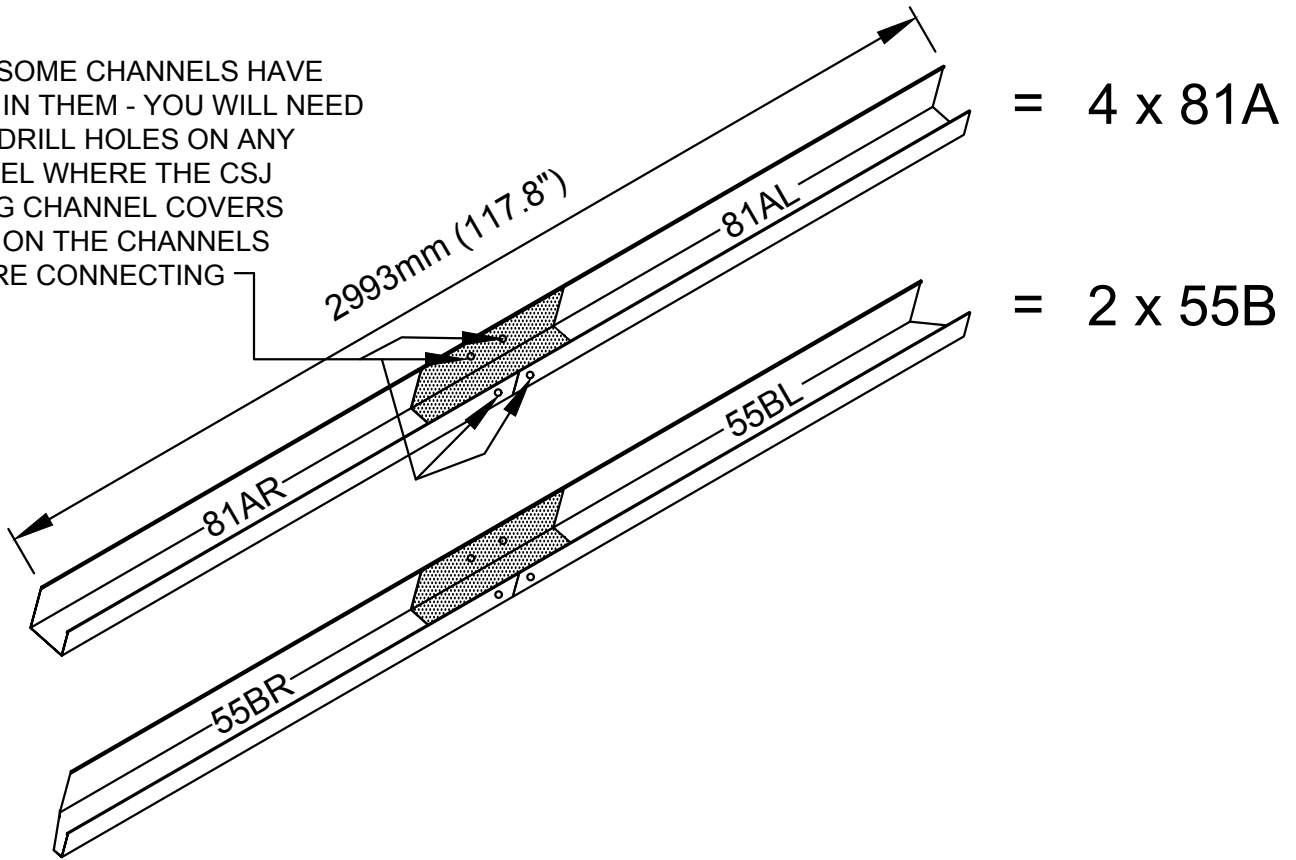



**VIEW OF ROOF COMPONENTS**

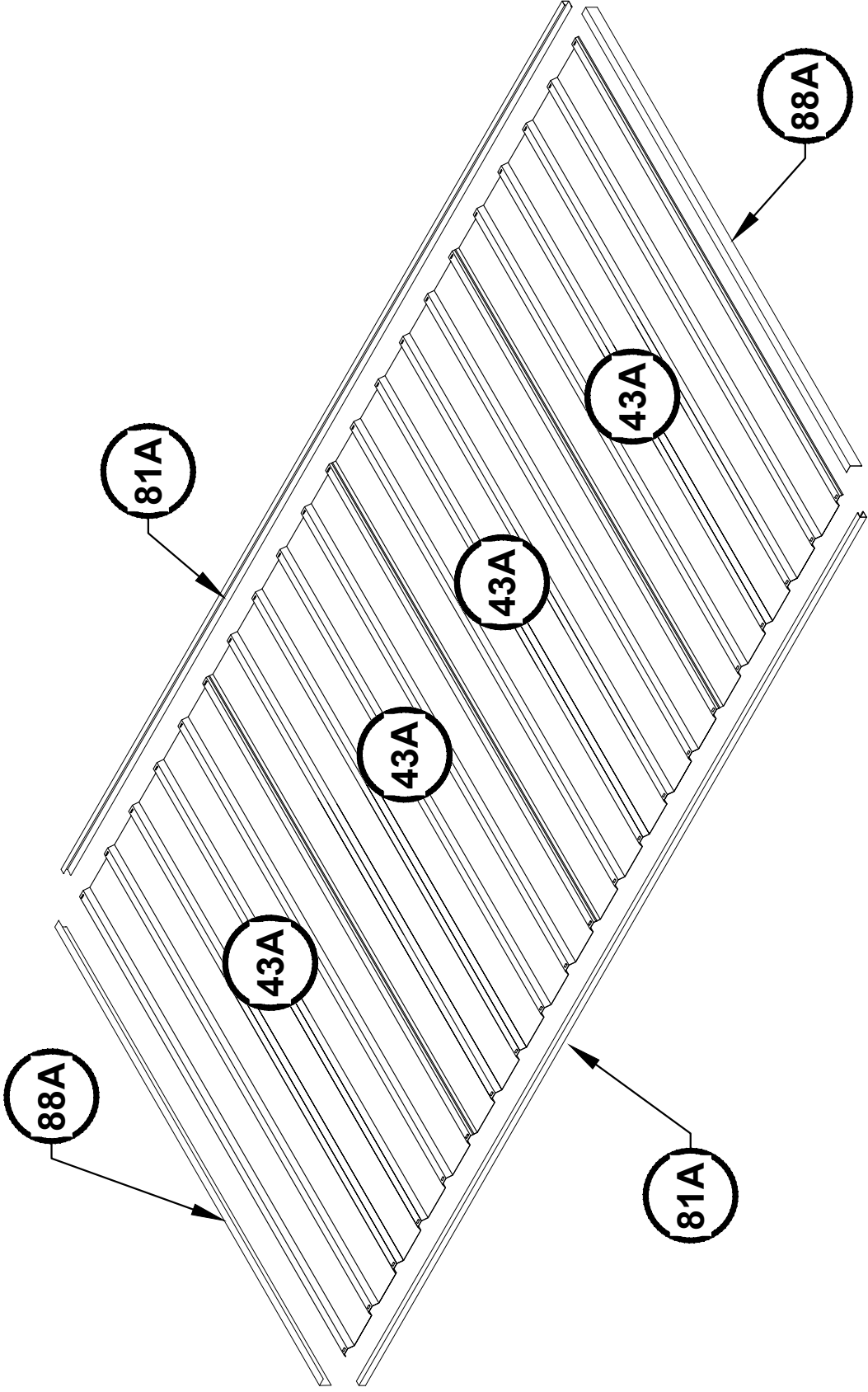



INSTRUCTIONS  
AND VIDEOS

# Absco Economy Shed Model: J15301FK

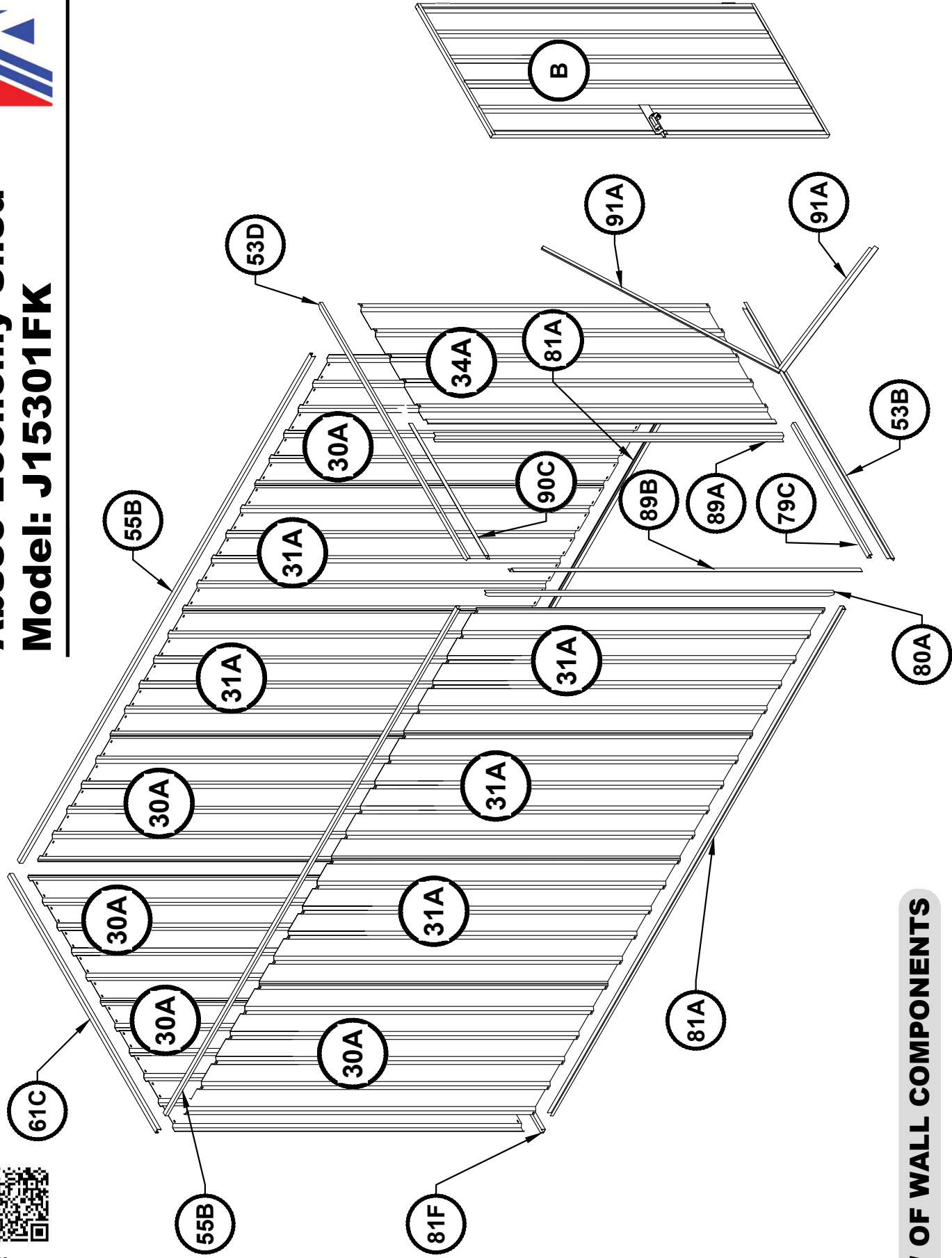

## VIEW OF WALL COMPONENTS





### ABSCO ASSEMBLY INTRODUCTION

The snaptite assembly system locks most perimeter channels to all roof and wall sheets without the need for tools and fasteners.

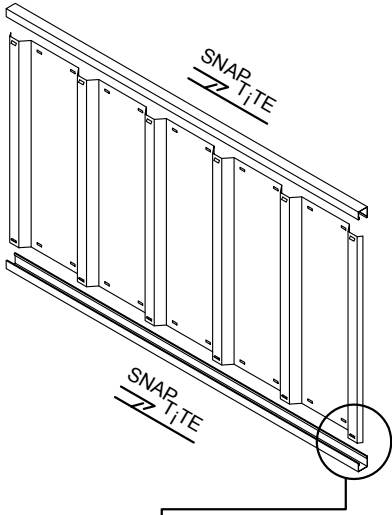

To pre-assemble the four wall panels and two roof panels, the perimeter channels are secured to the top and bottom of each panel using the snaptite system, as detailed on the following pages wherever you see the symbol.

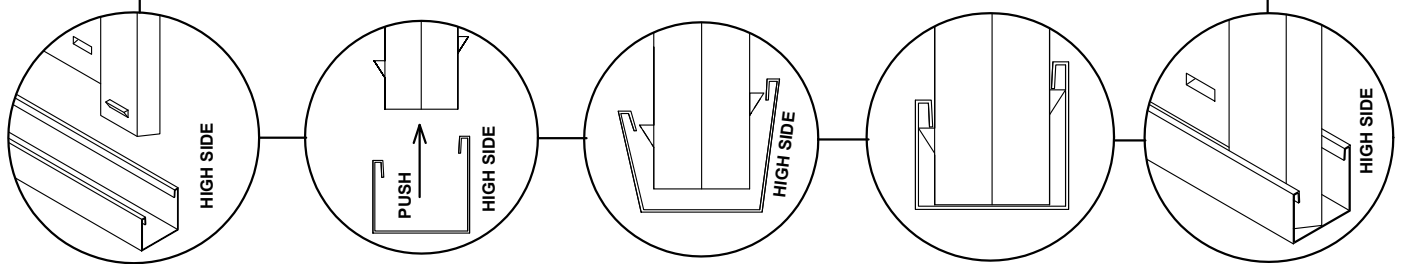
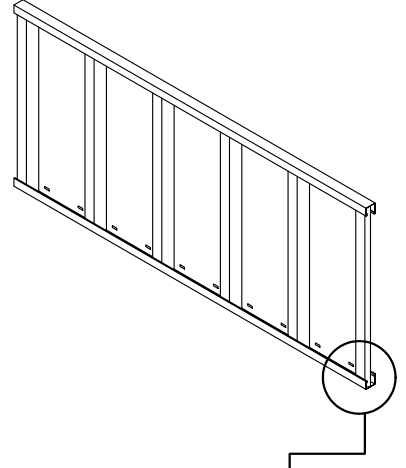

After joining sheets together, position channel over one end of the sheets, gently tapping it over the snaptite lugs, working along the sheets to the other end.

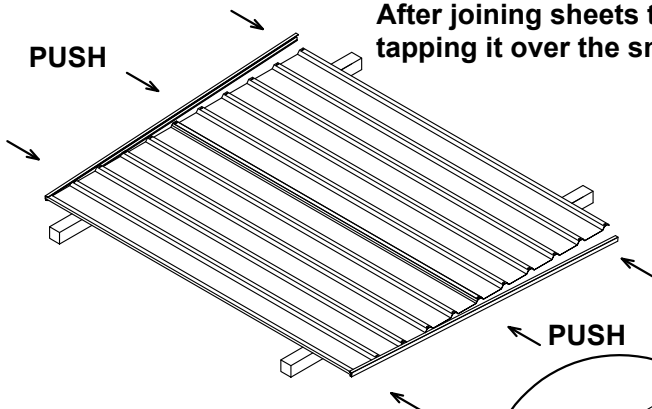

Position sheets on timbers, trestles or partly over edge of concrete slab.

Each perimeter channel must finish flush with the edges of the sheets. The snaptite system allows adjustment for this process by simply tapping the channel along the sheets until each end is neatly flush. If you need to remove channels from the panels, pull the channel along the panel from opposing ends. You may need someone to help with this.

### FASTENING SYMBOLS

 **D** Join components together by pre-drilling the holes first. Use one component as a template to mark where the holes are. Drill with 3mm drill bit.

 Join components together with one screw at this location only, as some channel sections have extra holes that are not required for this model of garden shed

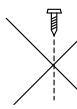
 Do not join components together at this location yet, as the screw may obstruct further assembly of other components

 3mm POP RIVETS

 4mm NUT & BOLT SET



### 1. REAR PANEL ASSEMBLY

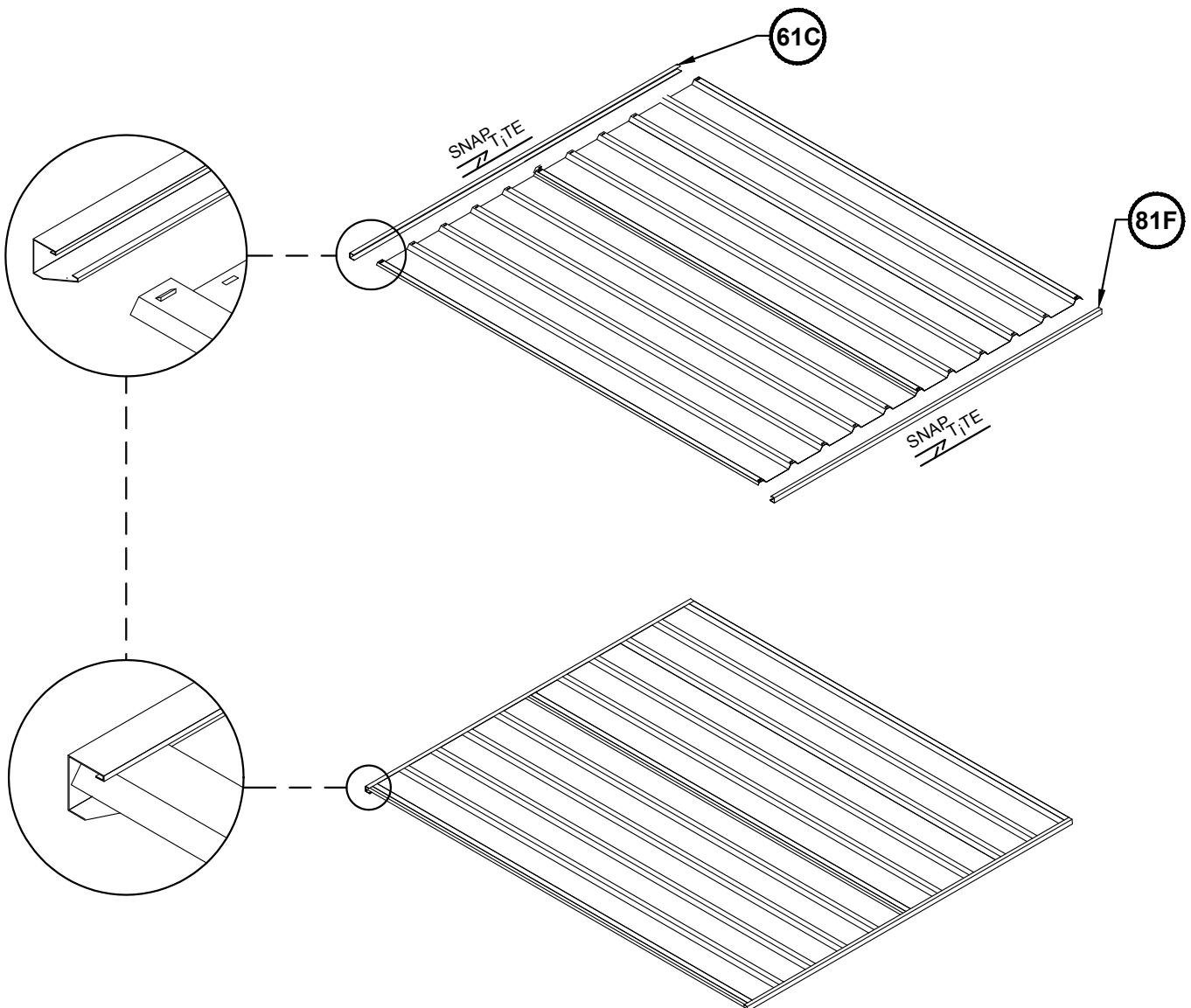
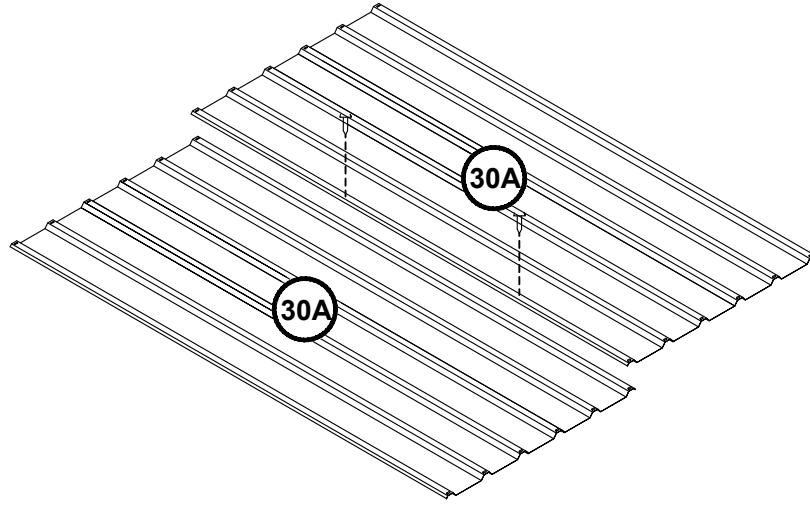



### 2. SIDE PANEL ASSEMBLY

#### LEFT SIDE PANEL



Reverse side of  
Door Mullion

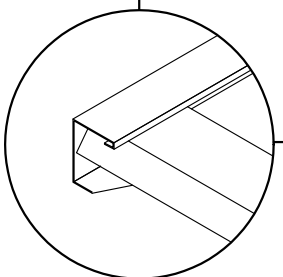
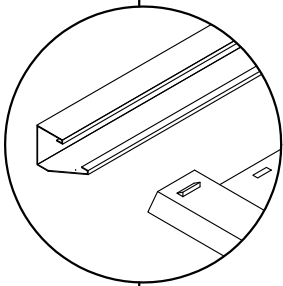
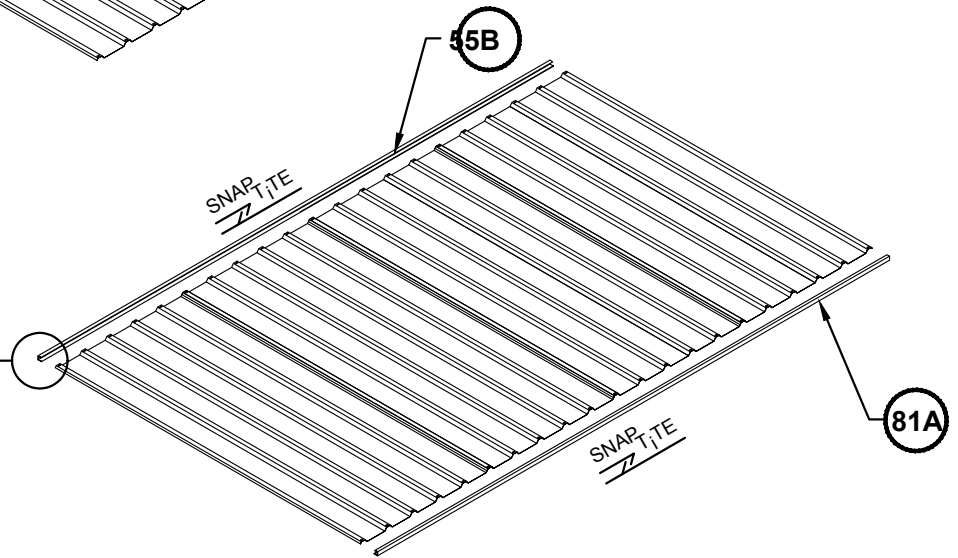
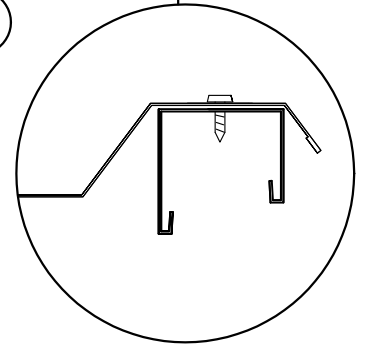
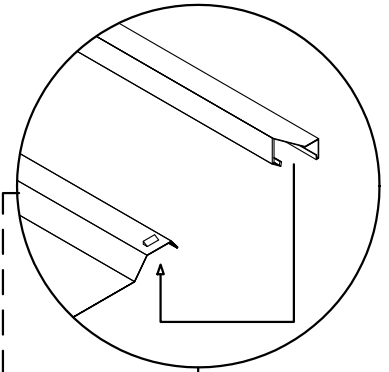
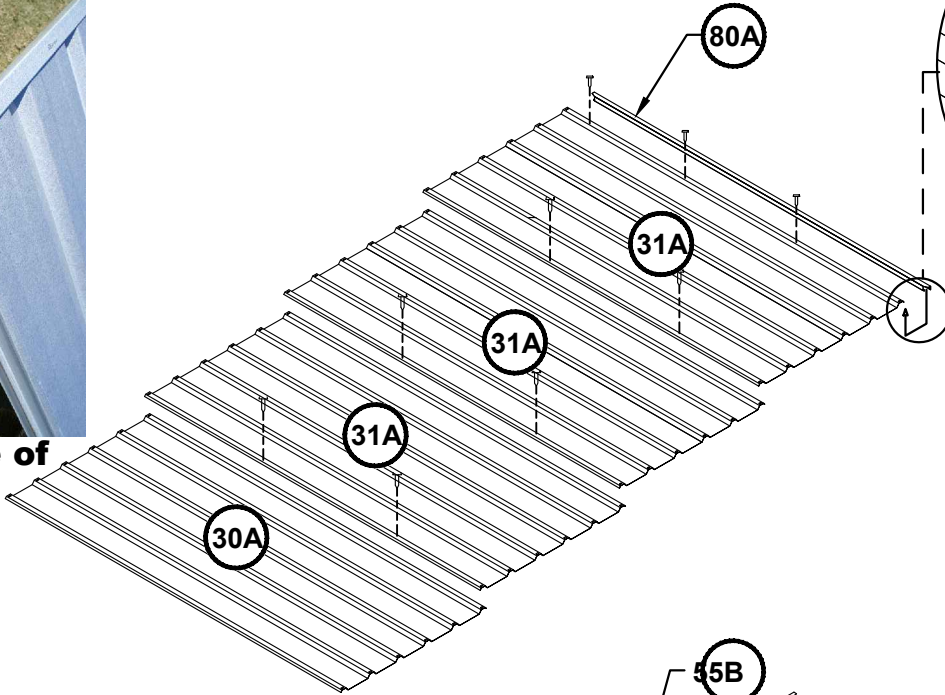



### 3. SIDE PANEL ASSEMBLY

#### RIGHT SIDE PANEL

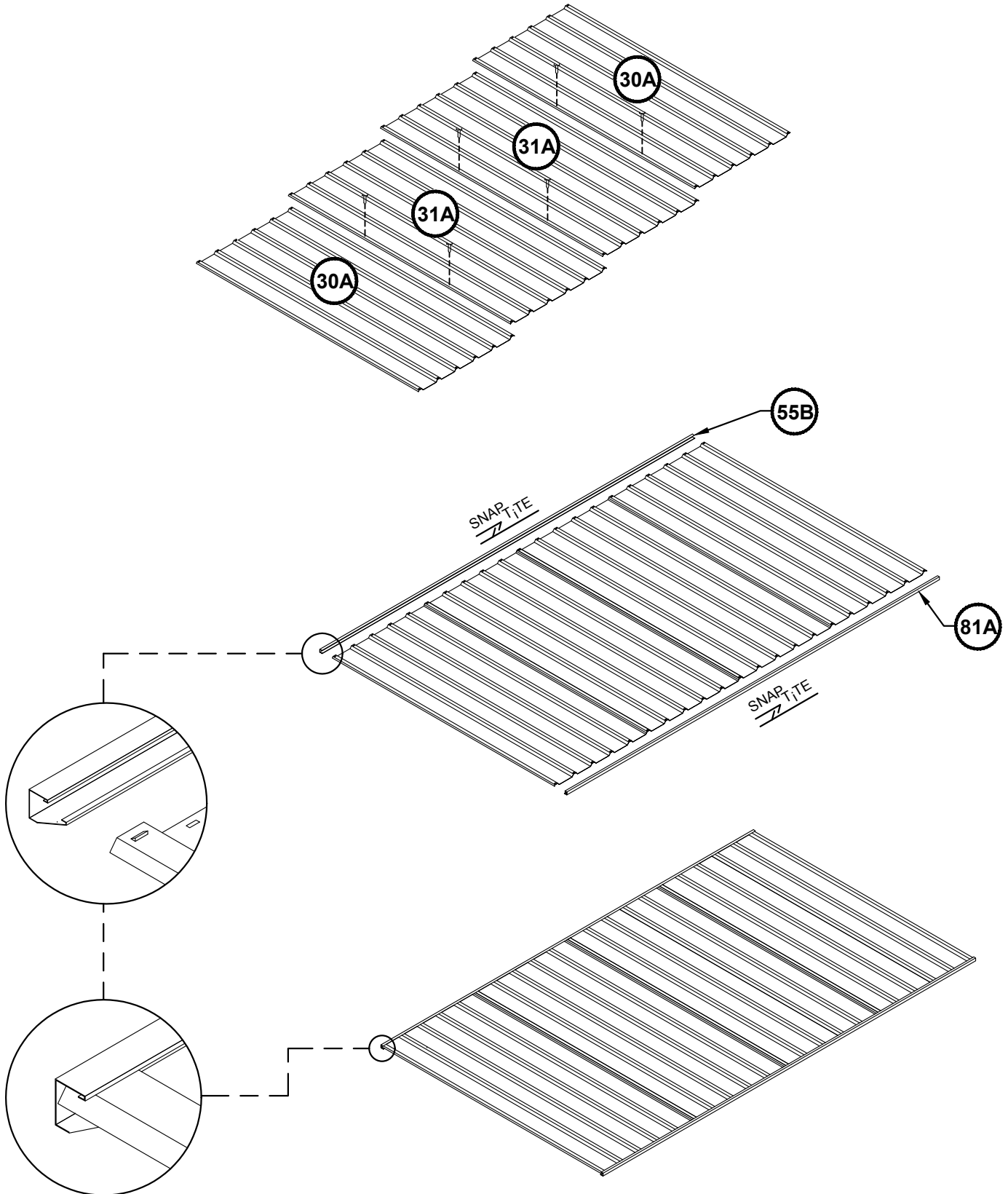



### 4. ROOF PANEL ASSEMBLY

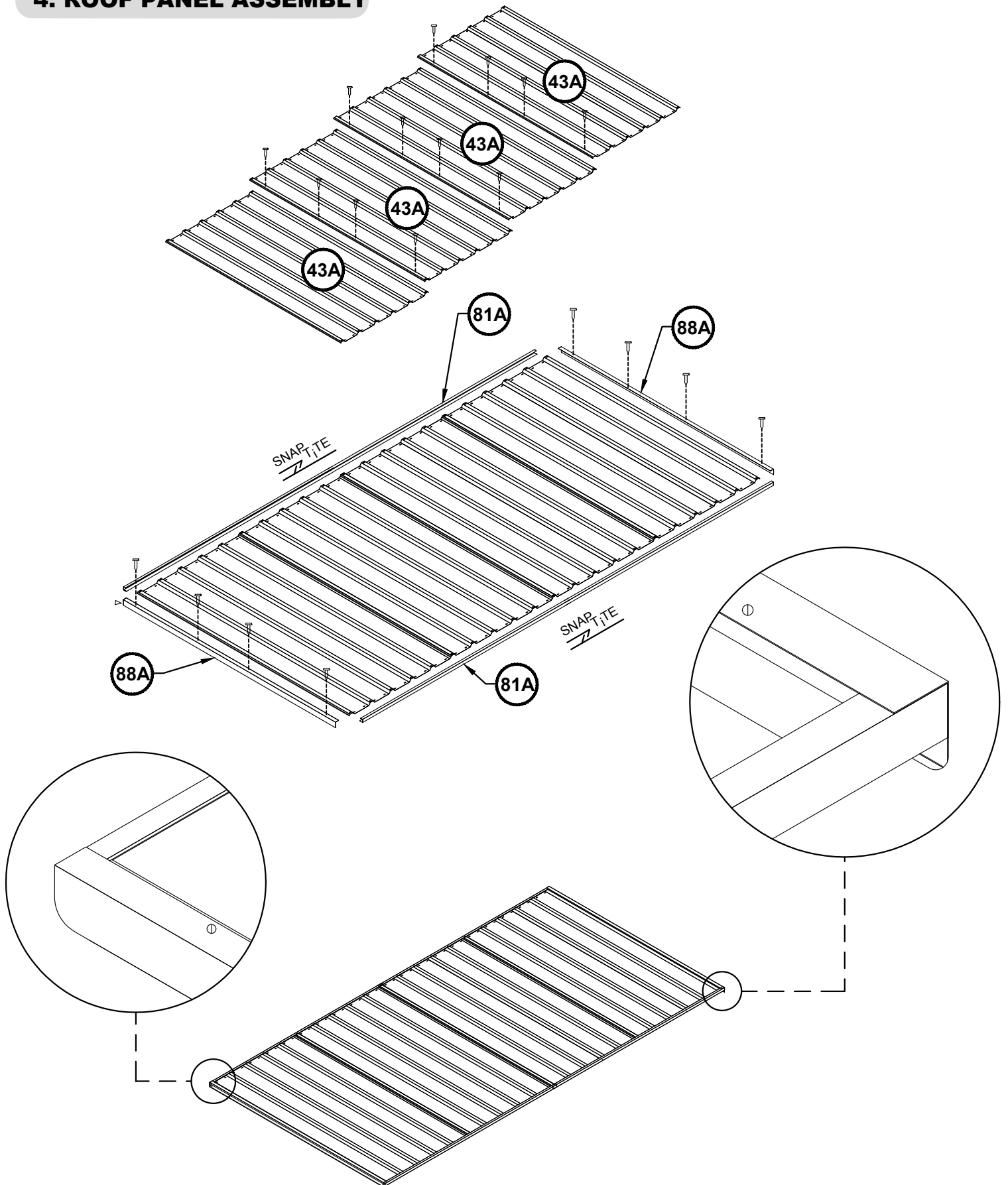



### 5. FRONT PANEL ASSEMBLY

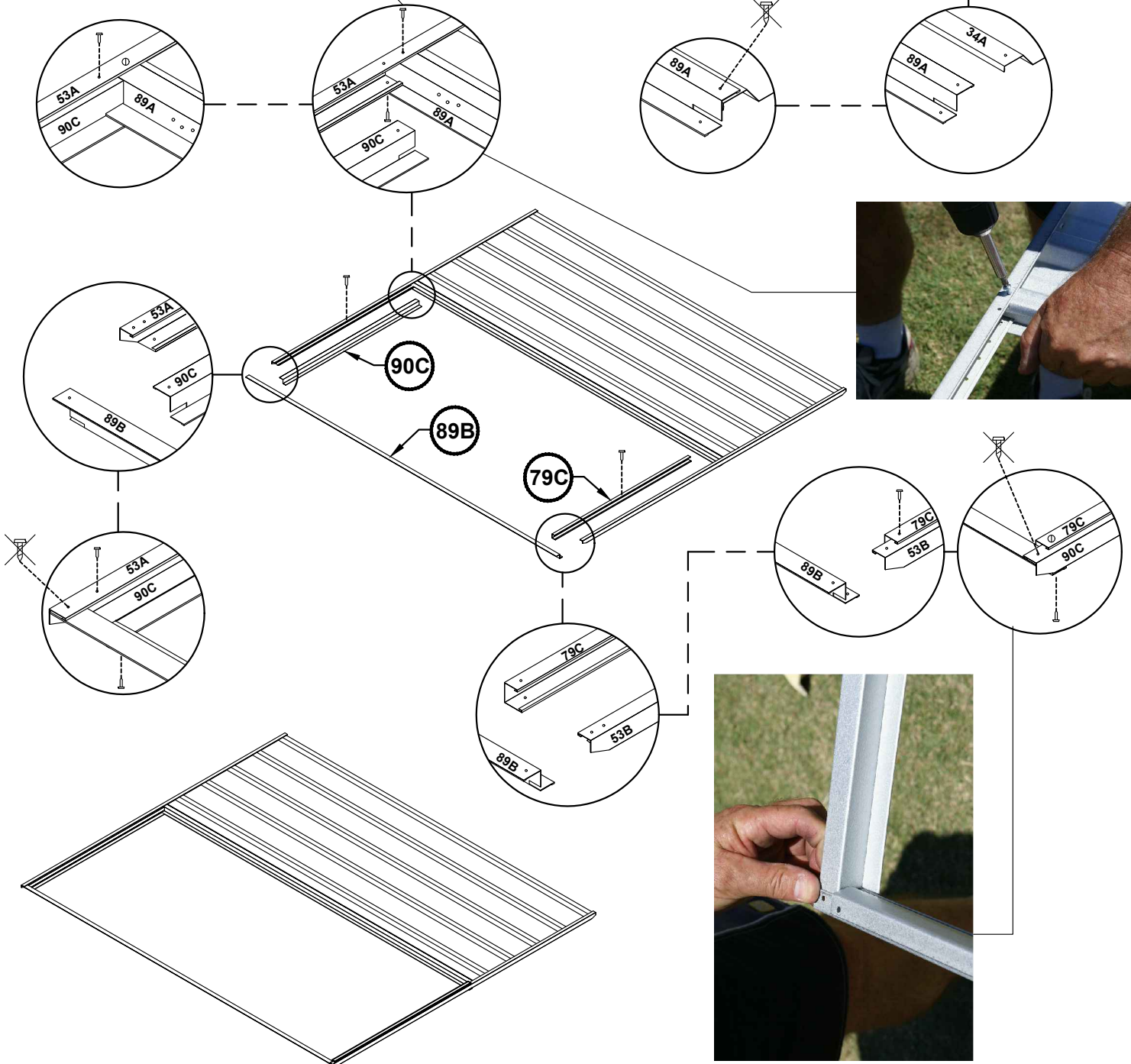
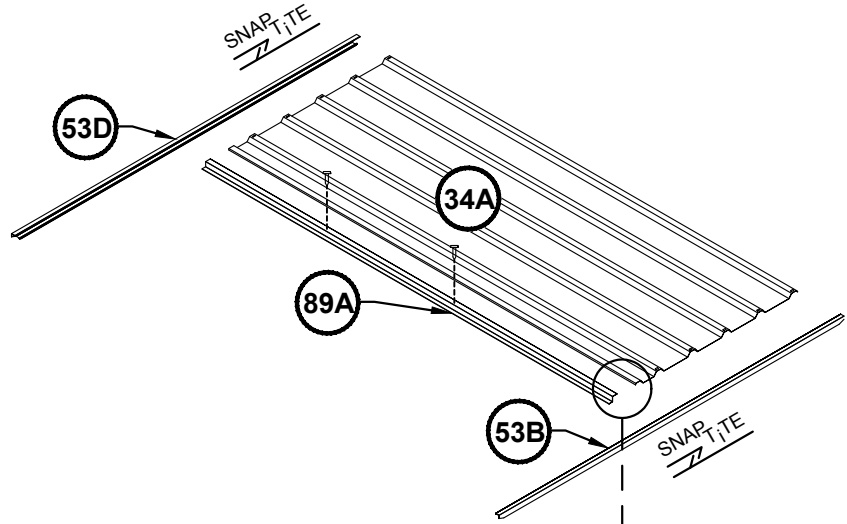



### 6. DOOR PANEL ASSEMBLY

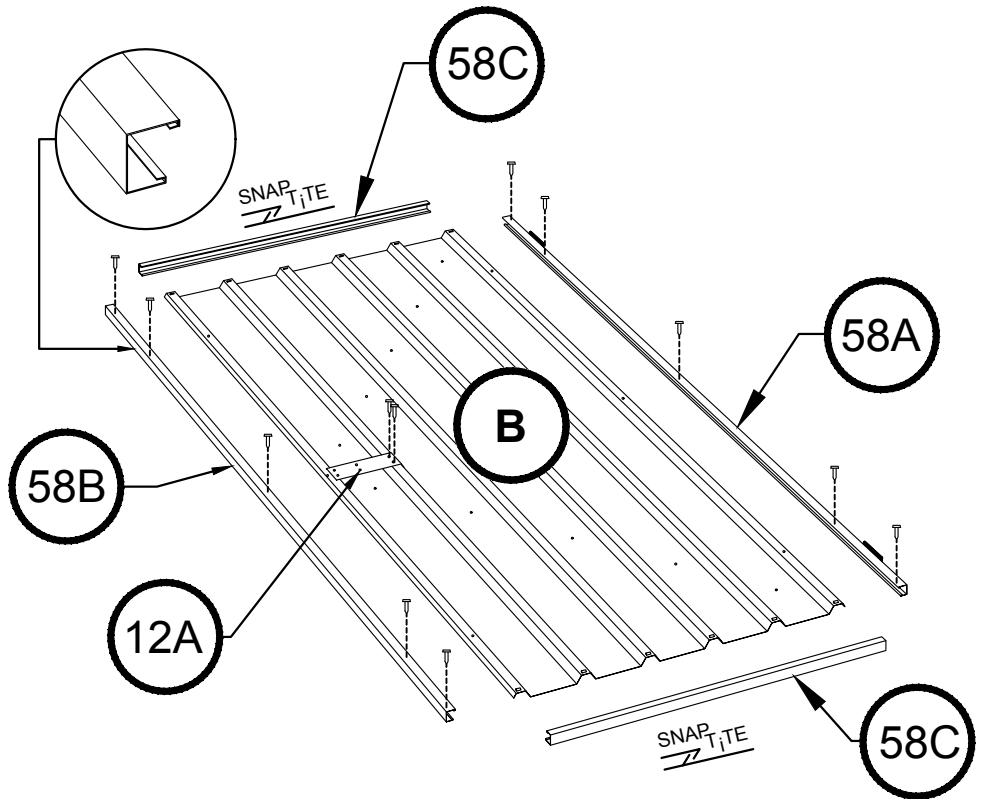

**ALL VERTICAL DOOR CHANNELS ARE INSTALLED IN THE REVERSE DIRECTION IN COMPARISON TO HORIZONTAL DOOR CHANNELS**

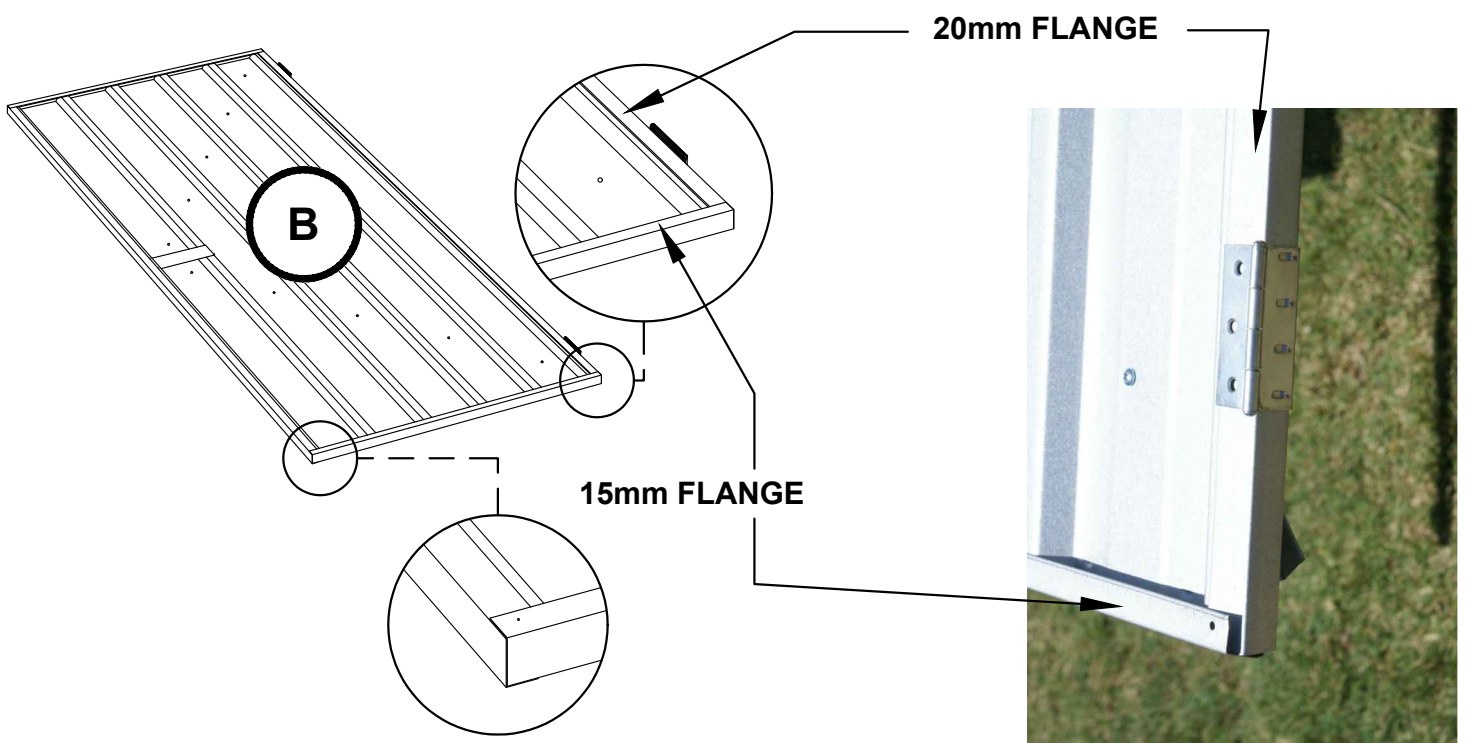



### 7. DOOR PANEL ASSEMBLY

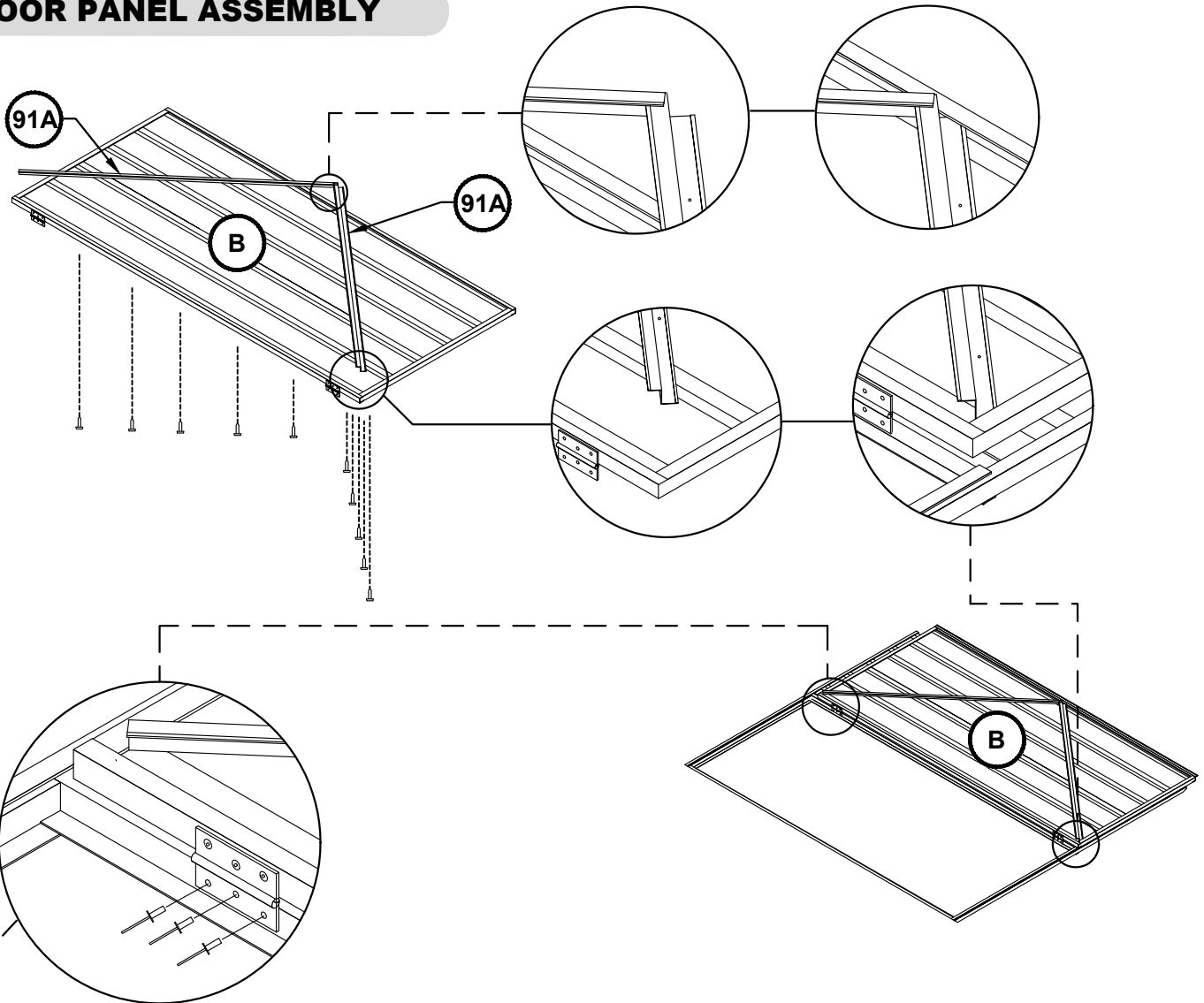

NOTE: NUTS AND BOLTS (SUPPLIED) MAY BE USED INSTEAD OF POP RIVETS (SUPPLIED) BY SIMPLY ENLARGING THE HINGE HOLE SETS IN THE JAMB USING A 4MM DRILL BIT

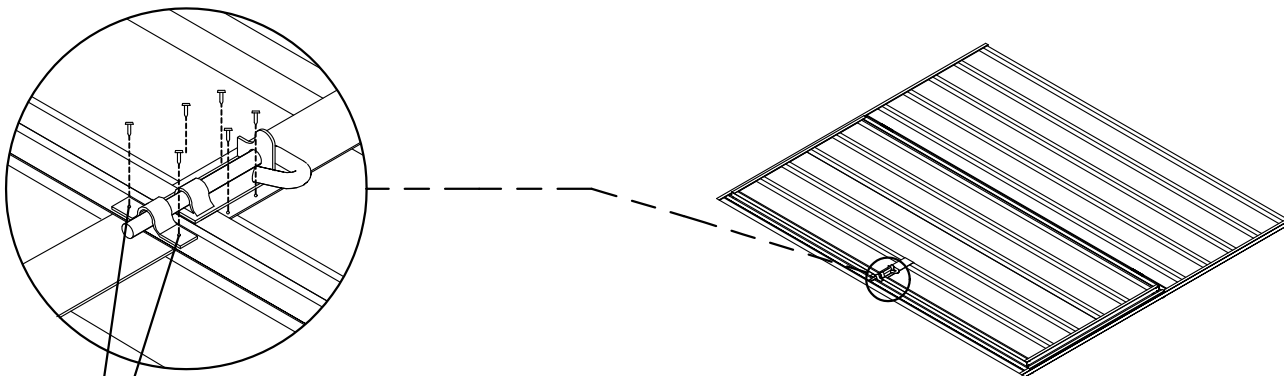

NOTE: The two holes required to connect the padbolt hasp for each door have not been pre-punched, to allow for proper alignment. position each hasp centrally over the padbolt shaft, and drill 3mm holes and secure with screws





### PANEL CONSTRUCTION

NOTE: Take care to ensure that both front and rear wall panels are not positioned upside down. The top channel of each panel is pre-punched for attaching roof sheets. The base channels are not pre-punched.

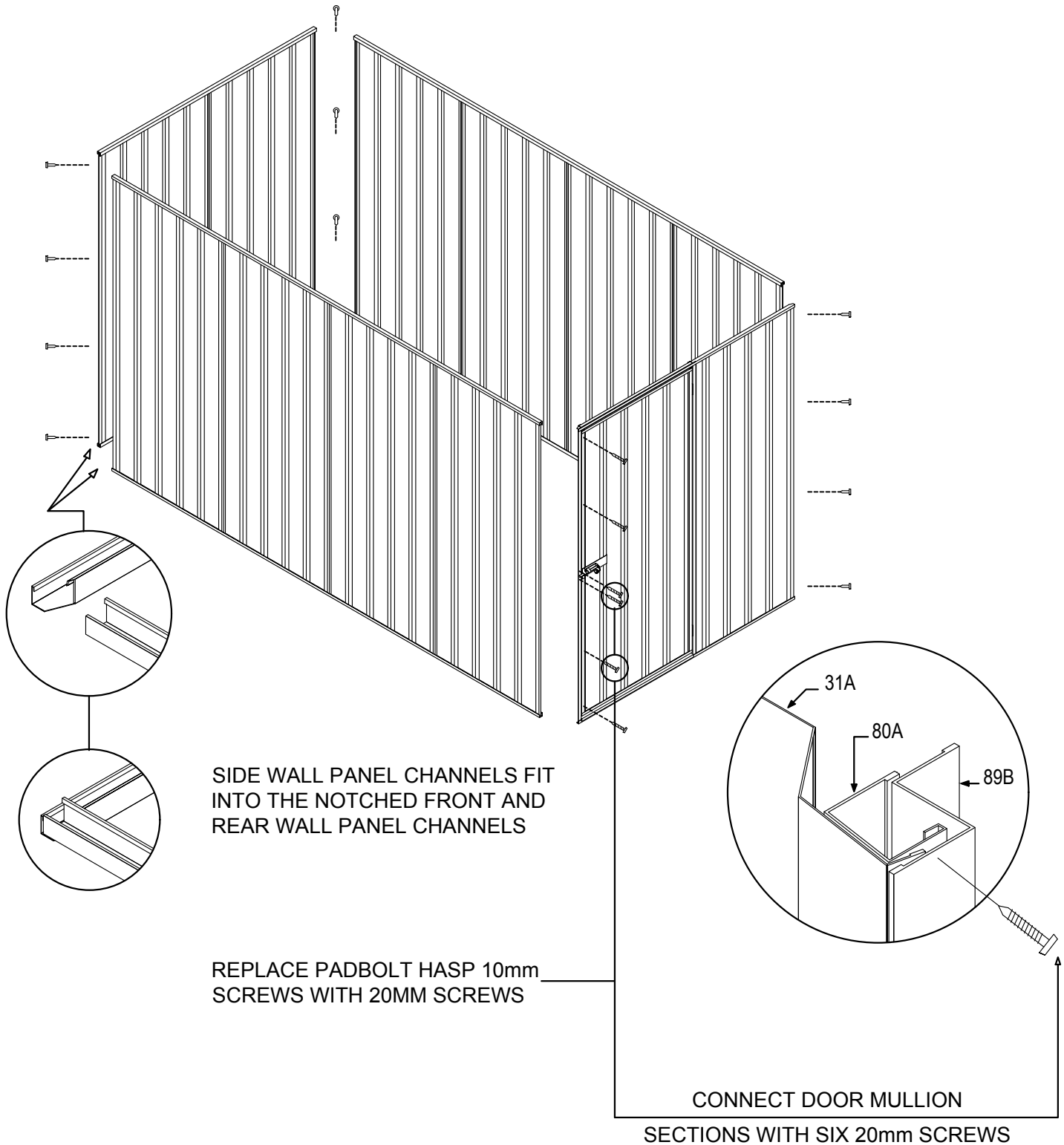



### FINAL CONSTRUCTION

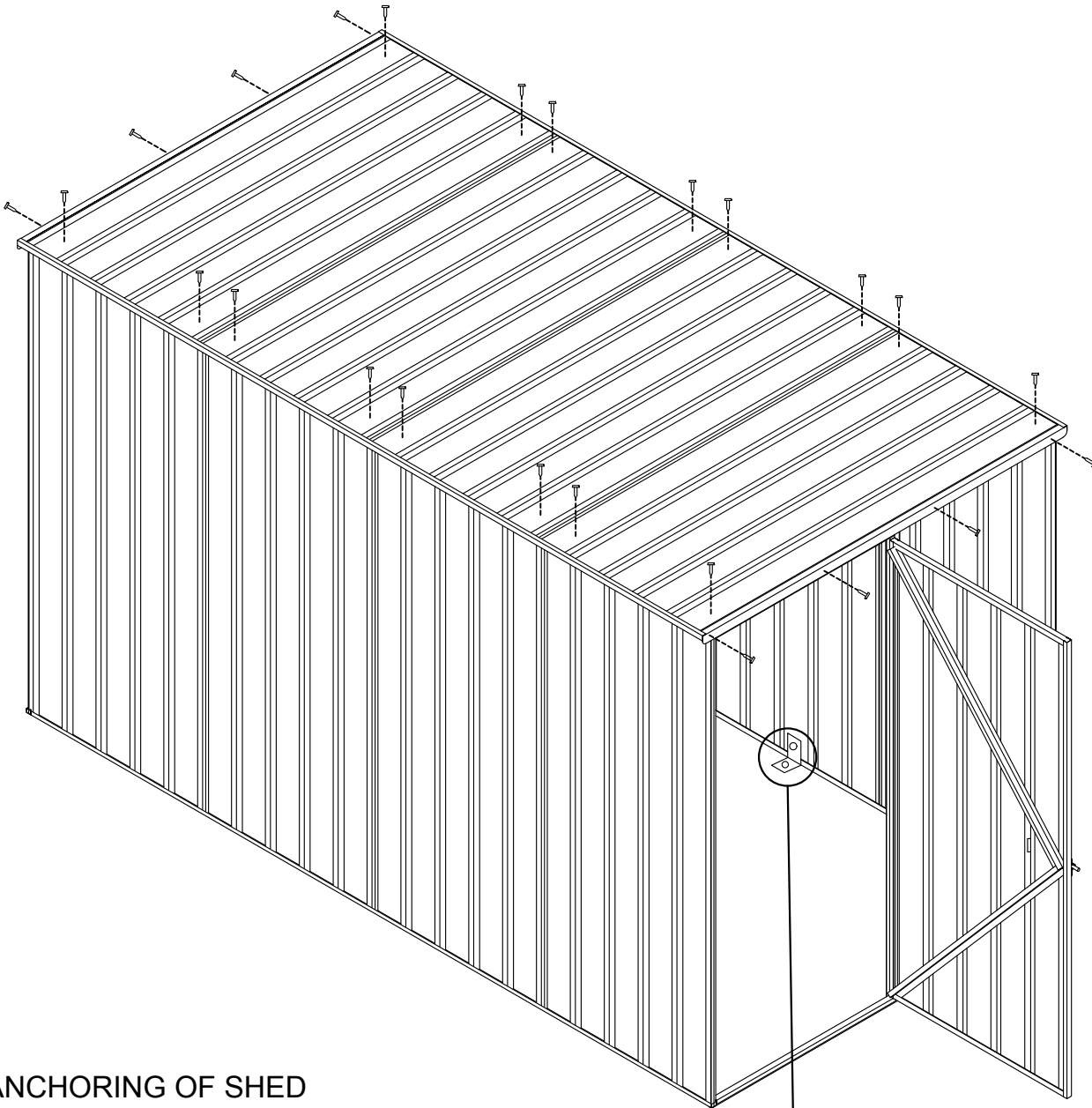

#### ANCHORING OF SHED

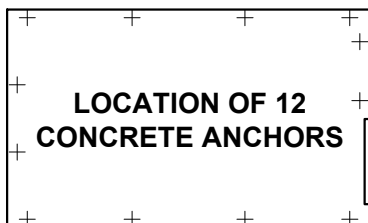

- EACH ANCHOR CONSISTS OF ONE NUT, BOLT, DYNABOLT AND STEEL ANGLE
- DRILL A 10mm HOLE INTO THE WALL SHEET
- DRILL A 10mm HOLE INTO THE CONCRETE

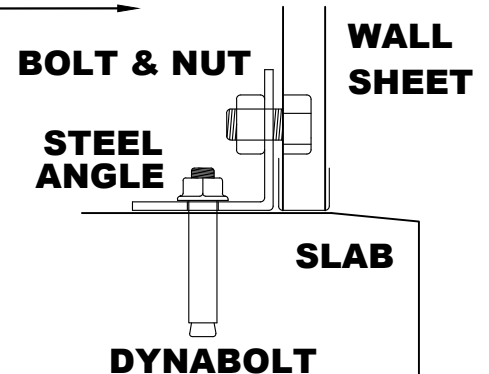

## AUSTRALIA PRODUCT WARRANTY AGAINST DEFECTS

### Congratulations on your purchase of an ABSCO SHED

ABSCO SHEDS, including garden sheds, garden beds, aviaries, storage units, garages, awnings and carports are made using high quality Australian made steel.

We are pleased to advise we warrant that the steel coating will not rust, crack, flake peel or blister for 30 years from date of purchase, when installed within Australia.

This warranty does not apply to surface deterioration of panels caused by 'Swarf' (Tiny particles of steel debris left from cutting, grinding or drilling operations) that has not been removed after building construction, or as a result of contact with damp soil, chemicals, fertilisers or other corrosive substances.

This warranty covers any Absco product used for normal domestic use and installed in accordance with the installation instructions. The warranty does NOT cover Damage caused by storms, wind, rain snow or poor foundations.

This warranty does NOT cover ABSCO products installed in severe coastal, industrial or other highly corrosive environments. The warranty does not cover fasteners (screws, nuts, bolts, rivets, hasps or sliding padbolts).

The warranty is limited to replacement and delivery of components and does not include any labour or installation costs. The benefits given by the warranty are in addition to your other rights and remedies under a law in relation to the goods or services to which the warranty relates.

The warranty applies to the exclusion of all other representations, guarantees or warranties express or implied, our goods come with guarantees that cannot be excluded under the Australian consumer law and is not transferable. You are entitled to a replacement or refund for a major failure and for compensation for any other foreseeable loss or damage. You are also entitled to have the goods repaired or replaced if the goods fail to be of an acceptable quality and the failure does not amount to a major failure. For further information go to <http://www.consumerlaw.gov.au>.

Please retain a proof of purchase (sales docket or invoice) or register your warranty within 30 days of purchase here: [www.absco.com.au/register\\_warranty.php](http://www.absco.com.au/register_warranty.php)

In the unlikely event a warranty claim is made, it must be supported by photographic evidence and details of the defect, including component part numbers, together with proof of purchase documentation (or on-line registration of purchase) and forwarded to the address below. Upon receipt of the warranty claim, the Customer Service Manager will contact you within three business days to advise you of the assessment outcome of the claim, which may include your expenses incurred in making the claim.

THE CUSTOMER SERVICE MANAGER, ABSCO INDUSTRIES, PO BOX 119 ACACIA RIDGE QLD AUSTRALIA 4110

PHONE: 1800 029701 FAX: 07-33441191 EMAIL: [warranty@absco.com.au](mailto:warranty@absco.com.au)

Issued 01 January 2013

## ABSCO SHEDS - STORAGE GUIDELINES

ABSCO SHEDS include garden sheds, garden beds, storage units, aviaries, garages, awnings and carports.

ABSCO SHEDS are designed to be weatherproof for normal weather conditions. In the event of extreme weather conditions such as heavy rain, combined with high wind gusts, the ridge capping, sheeting joints, screw fixings etc., may exhibit minor deformations which may allow some water entry. These areas should be checked regularly to ensure that maximum strength and protection is maintained.

Other weather conditions such as extreme heat and extreme cold, moist or dry air can influence the effects of concrete floor moisture and/or condensation on the underside of the roof sheets.

ABSCO SHEDS and storage units are primarily used for storage of garden equipment such as lawnmowers, wheelbarrows, garden tools etc. Storage items that might be adversely affected by any of the above conditions may require additional protection such as being sealed or covered by plastic sheets and/or stacked above the concrete floor on timber slats.

Waterproof sealants may be used to offer further protection where required around joins and screw fixings, as can rubber door seals and other products which are available from most hardware outlets.

Placement of waterproof sealants (silicone) between the base of the shed and concrete slab is not recommended, as this process can have a reverse effect, preventing excess water from escaping, resulting with water accumulating and being trapped inside the shed.

Absco accepts no responsibility for water entry, floor moisture, condensation or the condition of the Contents inside your Absco steel building arising from any of the pre-mentioned weather conditions.