

## ASSEMBLY INSTRUCTIONS FOR MAXI 400J3

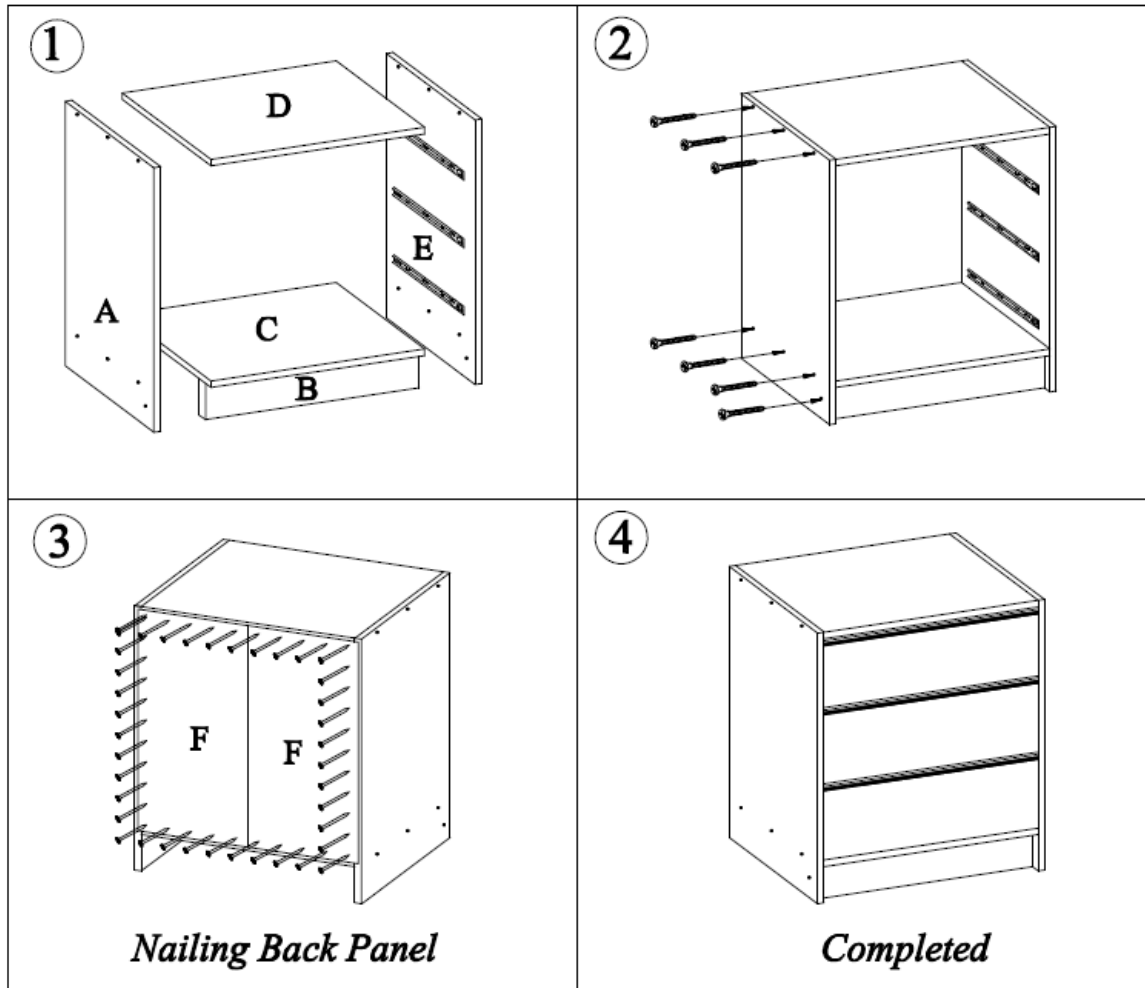

## HARDWARE LIST

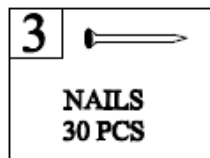

# ASSEMBLY INSTRUCTIONS FOR MAXI 400J3

**CABINET GABLES: ( H 745 X L 608 X D 450 mm )**

A = LEFT HAND  
E = RIGHT HAND

**CABINET RUNNERS:**

CL = LEFT HAND  
CR = RIGHT HAND

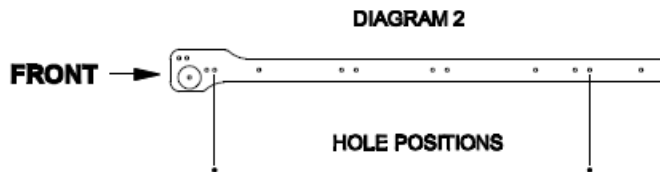

**7.5mm EURO SCREWS TO  
ATTACH RUNNERS TO CABINET  
GABLES**

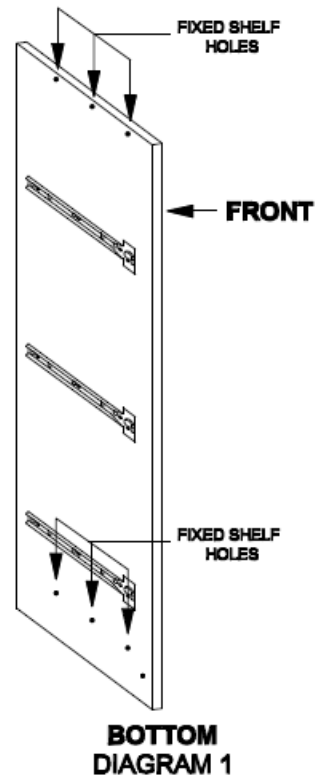

## INSTRUCTIONS:

- Lay cabinet gables marked **A** & **E** on floor and attach the metal cabinet runners to the cabinet gables refer to **Diagram 1**.
- It is important that the runners are fixed to the correct cabinet gables, fix runner marked **CL** to cabinet gable **A** and fix runner marked **CR** to cabinet gable **E** using the special 7.5mm Euro screws provided.
- **Important:** Please note **DIAGRAM 2** this shows the positions of the holes that the metal runners are fixed into.