

# RYOBI®

R18WV

ORIGINAL INSTRUCTIONS

# Window Vacuum



## **Important!**

This appliance is not intended for use by persons (including children) with reduced physical, sensory or mental capabilities, or lack of experience and knowledge, unless they have been given supervision or instruction concerning use of the appliance by a person responsible for their safety. Children should be supervised to ensure that they do not play with the appliance.

It is essential that you read the instructions in this manual before assembling, operating, and maintaining the product.

Subject to technical modifications.

Safety, performance, and dependability have been given top priority in the design of your window vacuum.

### INTENDED USE

The window vacuum is only intended for vacuuming fluids on smooth vertical surfaces such as windows, mirrors, and tiles.

The product is not intended to vacuum up larger amounts of fluids from horizontal surfaces, and is not intended to suck dust.

The product is to be used with conventional window cleaners only, not spirit or foam cleaners.

Do not use the product in any way other than those stated for intended use.

### WINDOW VACUUM SAFETY WARNINGS

- Save these instructions. Refer to them frequently and use them to instruct others who may use this tool. If you loan someone this tool, loan them these instructions also.
- Do not let familiarity gained from frequent use of tools allow you to become complacent and ignore tool safety principles. A careless action can cause severe injury within a fraction of a second.
- Keep handles and grasping surfaces dry, clean and free from oil and grease. Slippery handles and grasping surfaces do not allow for safe handling and control of the tool in unexpected situations.
- The product is intended for household use only.
- Use the product only for its intended use as described in this manual.
- The product is not intended to vacuum fluids from horizontal surfaces, and is not intended to suck dust.
- If the product is not working properly, has been dropped, damaged, left outdoors or dropped into water, return to your nearest service centre.
- Do not handle the product or charger with wet hands.
- Do not put any objects in ventilation openings. Do not use the product with any opening blocked. Keep openings free of dust, lint, hair and anything that may reduce air flow.
- Use extra care when using the product on stairs.
- Do not place the product near fire or heat. They may explode.
- The product should be charged in a location where the temperature is more than 10°C but less than 38°C.

### ⚠ CAUTION

If water is exiting from the exhaust vent, turn off the product immediately and empty the catch tank. Dry the product off and remove the battery to check for water. Dry off any water immediately.

### BATTERY AND CHARGER SAFETY WARNINGS

- Connect and disconnect the battery pack properly.
  - To install battery pack:
    - Place the battery pack on the product.
    - Make sure the latches on each side of the battery pack snap into place and the battery pack is secured on the product before beginning operation.
  - To remove battery pack:
    - Depress the latches on the side of the battery pack.
    - Remove the battery pack from the product.
- Remove battery when the product is not in use and before servicing.
- Use power tools only with specifically designated battery packs. Use of any other battery packs may create a risk of injury and fire.
- When battery pack is not in use, keep it away from other metal objects, like paper clips, coins, keys, nails, screws or other small metal objects, that can make a connection from one terminal to another. Shorting the battery terminals together may cause burns or a fire.
- Under abusive conditions, liquid may be ejected from the battery; avoid contact. If contact accidentally occurs, flush with water. If liquid contacts eyes, additionally seek medical help. Liquid ejected from the battery may cause irritation or burns.
- Do not use a battery pack or tool that is damaged or modified. Damaged or modified batteries may exhibit unpredictable behaviour resulting in fire, explosion or risk of injury.
- Do not expose a battery pack or tool to fire or excessive temperature. Exposure to fire or temperature above 130 °C may cause explosion.
- Recharge only with the charger specified by the manufacturer. A charger that is suitable for one type of battery pack may create a risk of fire when used with another battery pack.
- Follow all charging instructions and do not charge the battery pack or tool outside the temperature range specified in the instructions. Charging improperly or at temperatures outside the specified range may damage the battery and increase the risk of fire.
- Do not expose charger to wet or damp conditions.
- Do not place batteries near fire or heat. They may explode.
- Use of an attachment not recommended or sold by the battery charger manufacturer may result in a risk of fire, electric shock, or injuries to person.
- To reduce risk of damage to charger body and cord, pull by charger plug rather than cord when disconnecting charger.
- Make sure cord is located so that it will not be stepped

on, tripped over, or otherwise subjected to damage and stress.

- An extension cord should not be used unless absolutely necessary. Use of improper extension cord could result in a risk of fire and electric shock. If extension cord must be used, make sure:
  - a) That pins on plug of extension cord are the same number, size and shape as those of plug on charger.
  - b) That extension cord is properly wired and in good electrical condition.
- Do not operate charger with a damaged cord or plug. If damaged, have it replaced immediately by a qualified serviceman.
- Do not operate charger if it has received a sharp blow, been dropped, or otherwise damaged in any way; take it to a qualified serviceman.
- Do not disassemble charger; take it to a qualified serviceman when service or repair is required. Incorrect reassembly may result in a risk of electric shock or fire.
- To reduce risk of electric shock, unplug the charger from outlet before attempting any maintenance or cleaning. Turning off controls will not reduce this risk.
- Disconnect charger from power supply when not in use.
- Risk of electric shock. Do not touch uninsulated portion of output connector or uninsulated battery terminal.
- Rechargeable batteries are to be removed from the product before being charged.
- Different types of batteries or new and used batteries are not to be mixed.
- Batteries are to be inserted with the correct polarity.
- Exhausted batteries are to be removed from the product and safely disposed of.
- If the product is to be stored unused for a long period, the batteries should be removed.
- The supply terminals are not to be short-circuited.
- Under extreme usage or temperature conditions, battery leakage may occur. If liquid comes in contact with skin, wash at least 10 minutes then seek immediate medical attention.
- Batteries vent hydrogen gas and can explode in the presence of a source of ignition, such as a pilot light. To reduce the risk of serious personal injury, never use any cordless product in the presence of an open flame. An exploded battery can propel debris and chemicals. If exposed, flush with water immediately.
- Electric shock could occur if the battery is charged outdoors or on wet surfaces.

## TRANSPORTING LITHIUM BATTERIES

Transport the battery in accordance with local and national provisions and regulations.

Follow all special requirements on packaging and labelling when transporting batteries by a third party. Ensure that no batteries can come in contact with other batteries or conductive materials while in transport by protecting exposed connectors with insulating, non-conductive caps or tape. Do not transport batteries that are cracked or leaking. Check with the forwarding company for further advice.

### ⚠ WARNING

The product is not intended for use by persons (including children) with reduced physical, sensory or mental capabilities, or lack of experience and knowledge, unless they have been given supervision or instruction concerning use of the product by a person responsible for their safety.

Children should be supervised to ensure that they do not play with the product.

### RESIDUAL RISKS

Even when the vacuum is used as prescribed, it is still impossible to completely eliminate certain residual risk factors. The following hazards may arise and the operator should pay special attention to avoid the following:

- Use the product only for its intended use. Do not alter or modify the product from the original design or function.
- Always be aware that misuse and improper handling of this vacuum can cause injury to yourself and others.
- Never vacuum up larger amounts of fluids from horizontal surfaces and do not vacuum dust.

### MAINTENANCE

- Cleaning and user maintenance shall not be made by children without supervision.
- Wipe the product dry after every use. Ensure the battery is dry.
- Do not clean with harsh chemicals or strong detergents.
- Empty liquid container and clean wiping cloth after every use for hygiene purposes.
- Keep rubber nozzle clean and free of foreign objects for optimal performance.

### ⚠ CAUTION

When the foam or liquid achieves MAX level of the indicator, empty the liquid container.

### ENVIRONMENTAL PROTECTION



Recycle raw materials instead of disposing of as waste. The machine, accessories and packaging should be sorted for environment-friendly recycling.

## SYMBOLS ON THE PRODUCT



Safety alert



No-load speed



Volts



Direct current



Please read the instructions carefully before starting the machine.



Regulatory Compliance Mark (RCM). Product meets applicable regulatory requirements.



Waste electrical products should not be disposed of with household waste. Please recycle where facilities exist. Check with your local authority or retailer for recycling advice.

## SYMBOLS IN THIS MANUAL



Note



Parts or accessories sold separately



Wash at or below 60°C.



Do not bleach.



Do not dry clean.



Do not iron.



Do not tumble dry.

The following signal words and meanings are intended to explain the levels of risk associated with this product:

### DANGER

Indicates an imminently hazardous situation, which, if not avoided, will result in death or serious injury.

### WARNING

Indicates a potentially hazardous situation, which, if not avoided, could result in death or serious injury.

### CAUTION

Indicates a potentially hazardous situation, which, if not avoided, may result in minor or moderate injury.

### CAUTION

(Without Safety Alert Symbol) Indicates a situation that may result in property damage.

## TROUBLESHOOTING

PROBLEM	SOLUTION
Vacuum has poor suction	Ensure that liquid container drain hole cover is closed. Ensure that nozzle is inserted fully. Ensure that liquid container separator is assembled correctly. Ensure that the nozzle and squeegee are clean. Remove squeegee to clean if necessary.
Resistance when moving squeegee nozzle on surface	Check if the surface is wet across the complete width of nozzle. Nozzle will grip and be noisy on dry surface.
Water is exiting from the exhaust vent	Check if liquid container is over filled. Do not use if liquid level is above MAX indicator. Check if detergent concentration is too high. Strong soap will create too much foam and raise above the MAX level. Avoid shaking the unit during use as it could bring liquid close to the suction port in liquid container.
Spray gun is not spraying	Check if spray nozzle is in SPRAY or STREAM position.

## BATTERY AND CHARGER

Model	Compatible battery pack (not included)	Compatible charger (not included)
	Model series RB18LXX** includes models below:	
Lithium-Ion	RB18L13	BCS618G
	RB18L15	BCL14181H
	RB18L20	BCL14183H
	RB18L20A	BCL14181V*
	RB18L25	RC18150
	RB18L25A	RC18150U
	RB18L40	RC18627U
	RB18L50	RC18115
		RC18120

\* for vehicles with 12V DC outlets

\*\* RB18L60A and RB18L90A is not suitable for use in this product

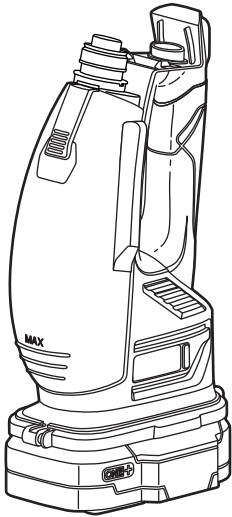
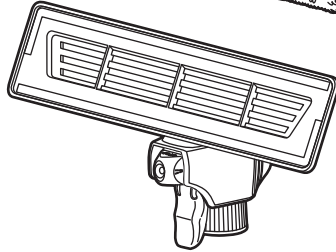
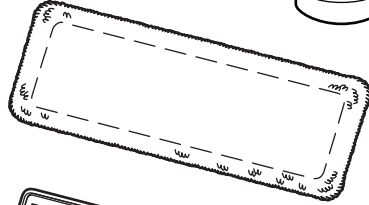
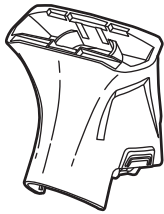
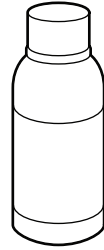
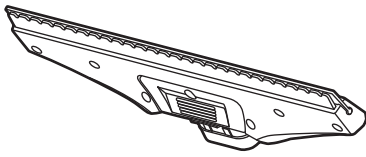

**RYOBI ONE+**  
18V System

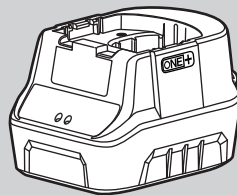
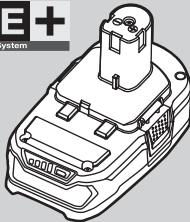

## KNOW YOUR PRODUCT

1. Nozzle with squeegee
2. Squeegee
3. Nozzle latch
4. Nozzle connector
5. Nozzle connector latch
6. Liquid container drain hole cover
7. Liquid container
8. Handle
9. Exhaust Vent
10. On / off switch
11. Wiping cloth
12. Spray nozzle
13. Wiping cloth holder
14. Spray trigger
15. Spray bottle
16. Battery port
17. Concentrate glass cleaner

\* 13. Wiping cloth holder and 15. Spray bottle cannot be disassembled.

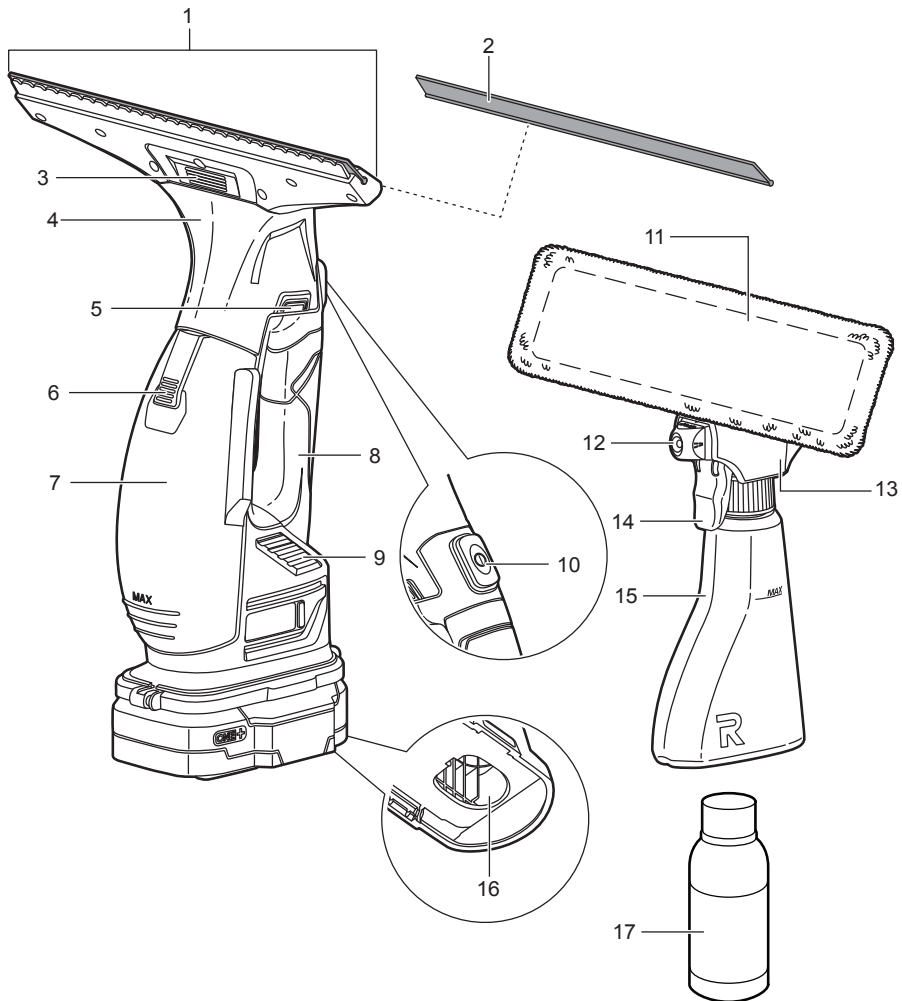

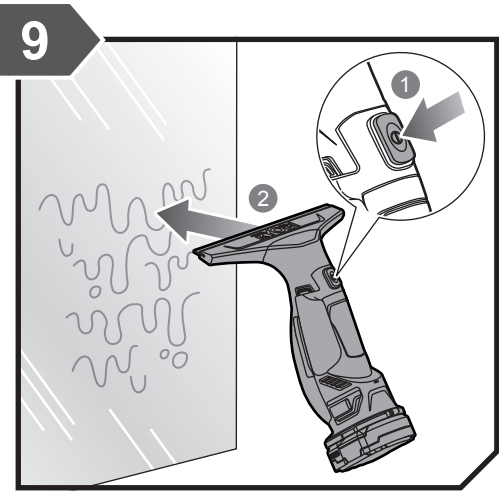
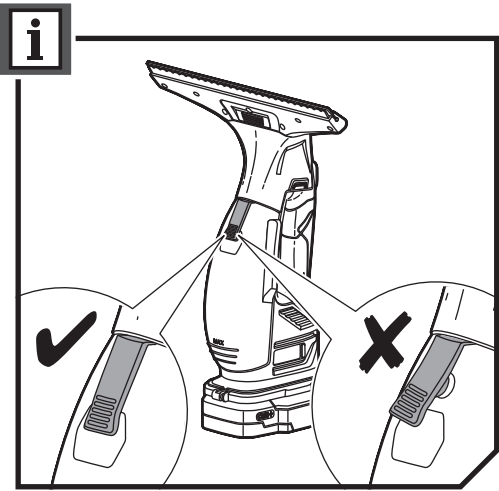
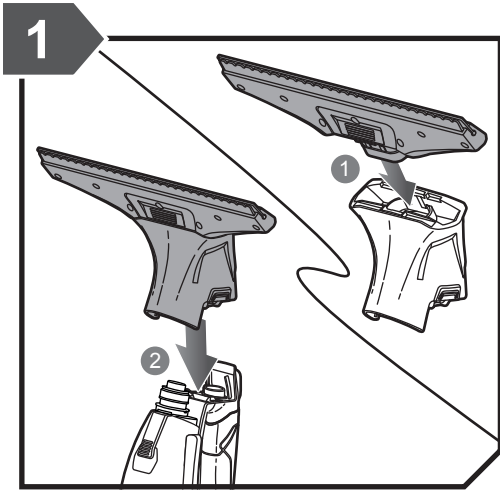



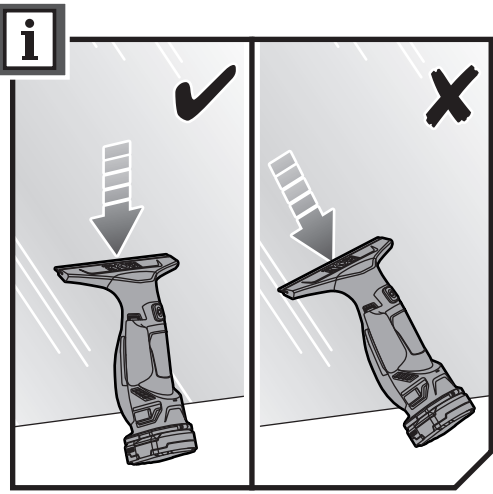
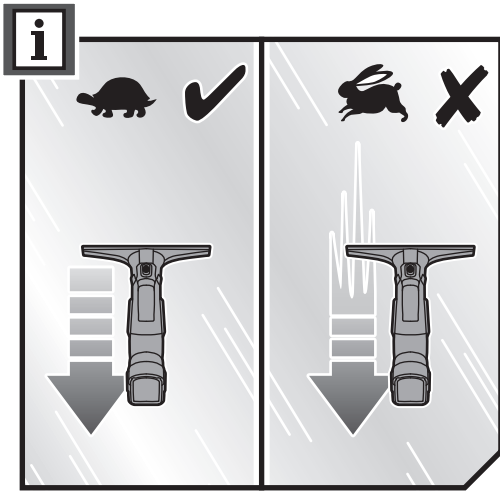
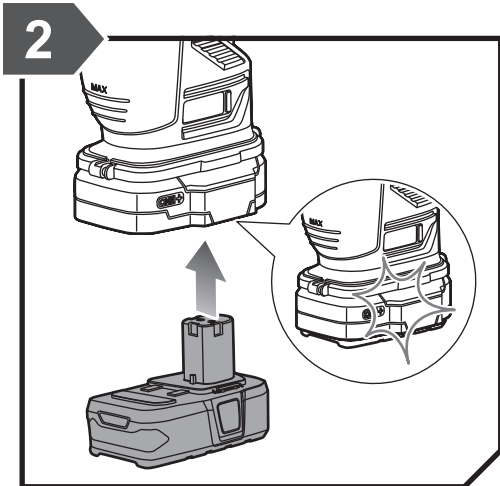

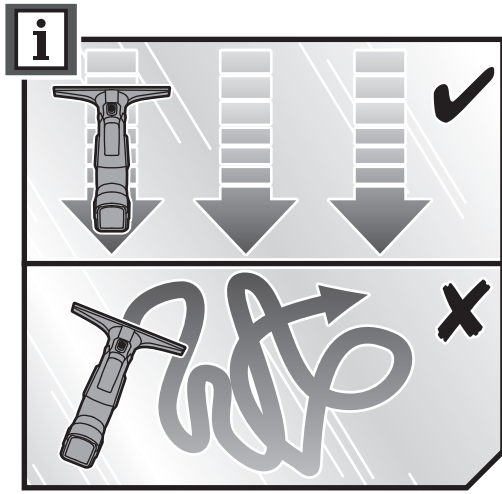
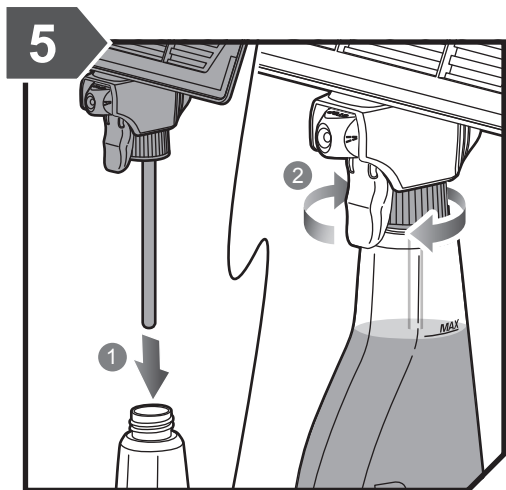
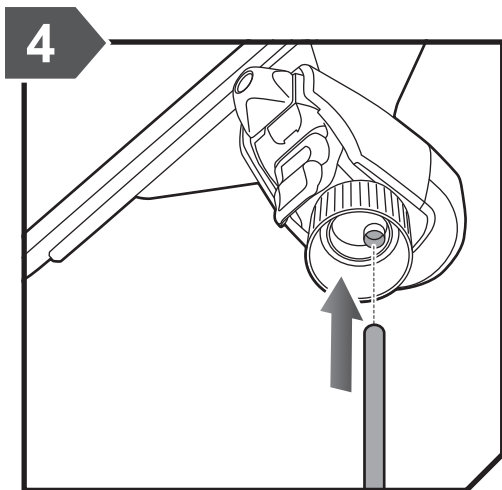

6

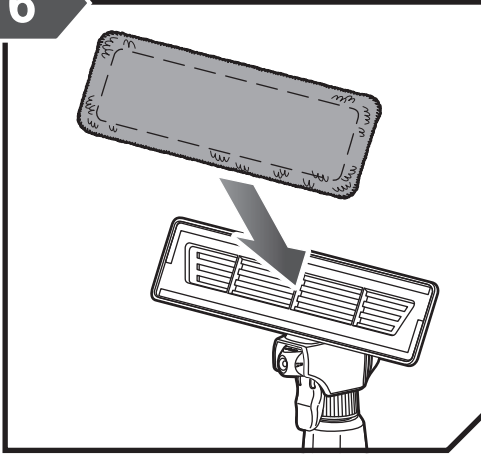

7

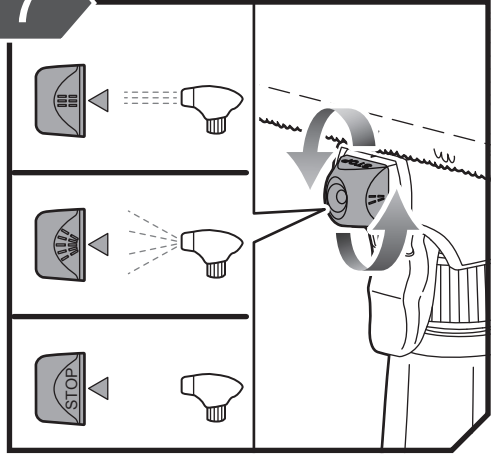

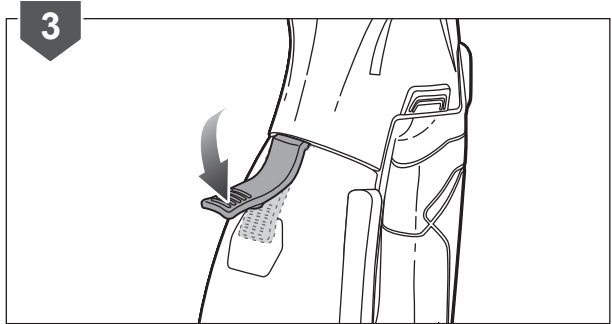
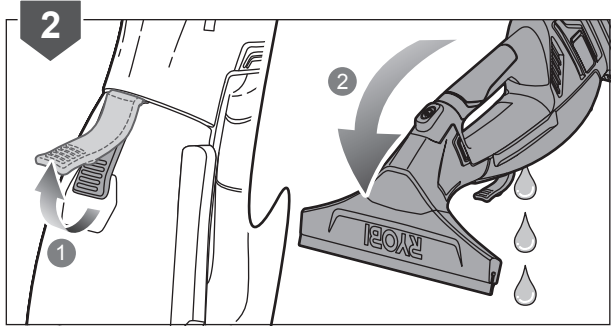
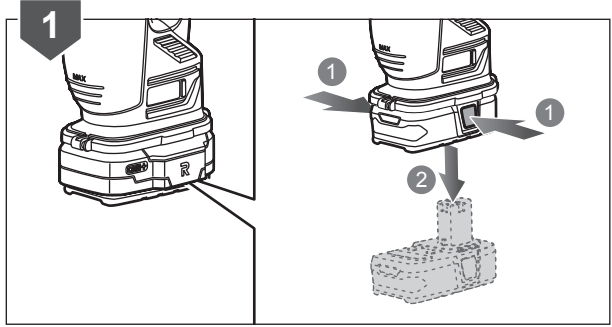
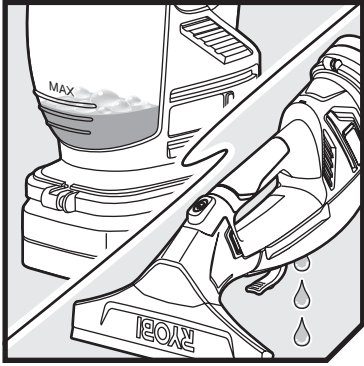

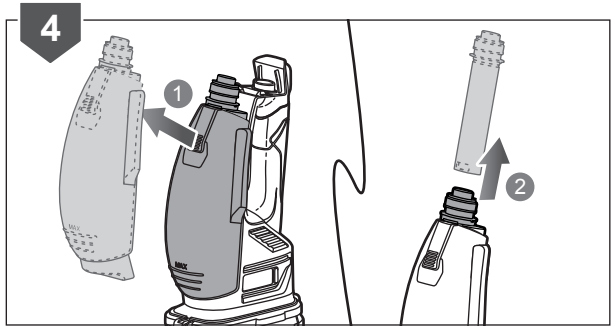
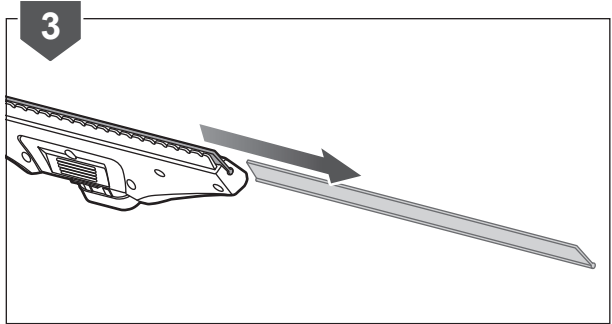
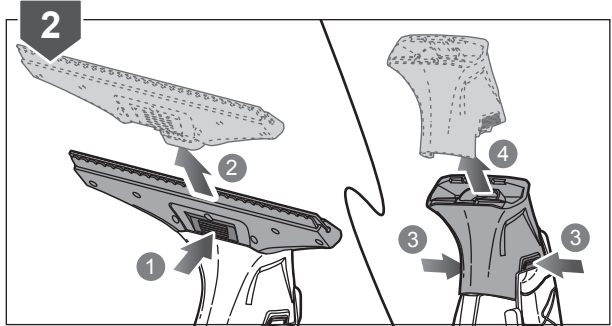
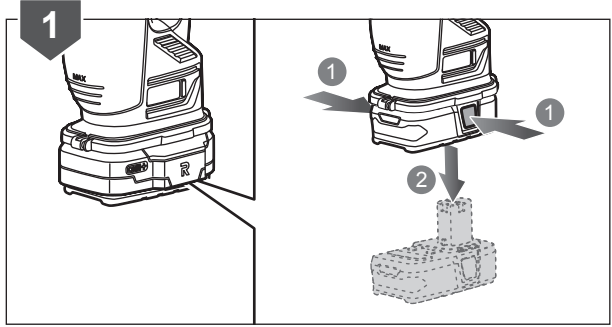
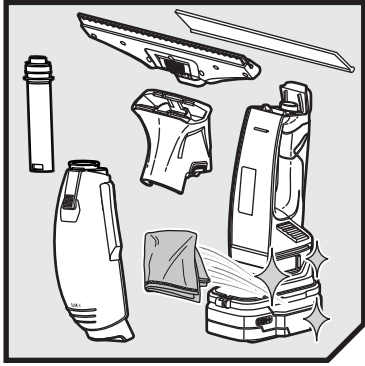

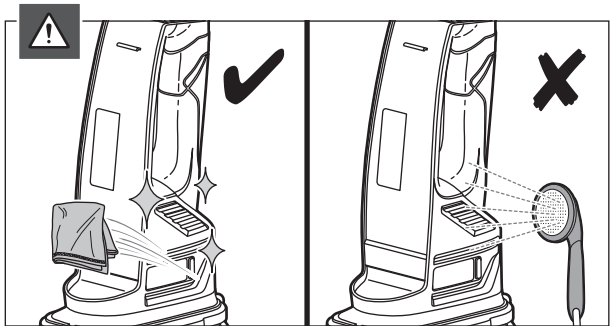
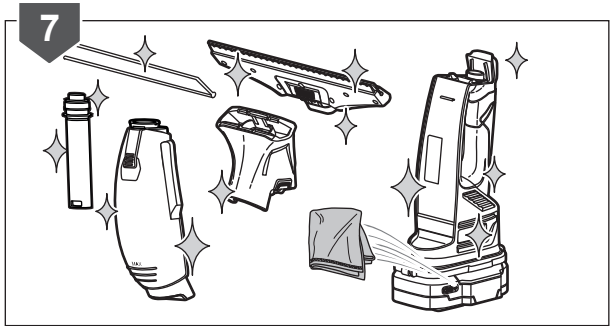
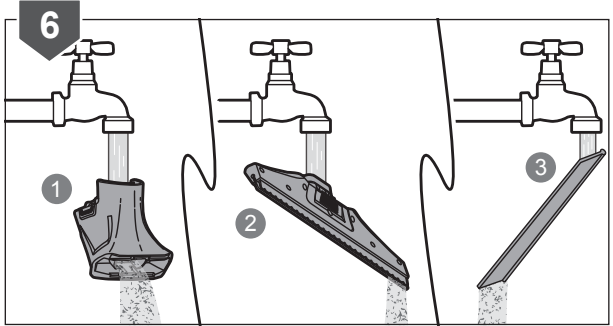
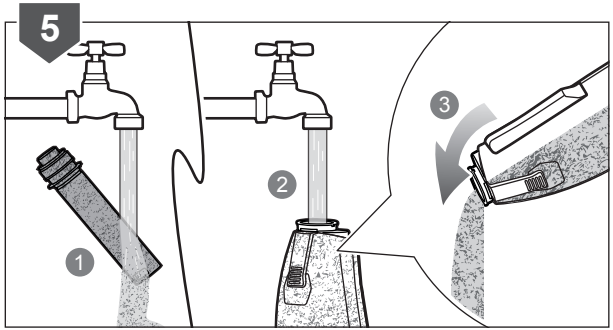

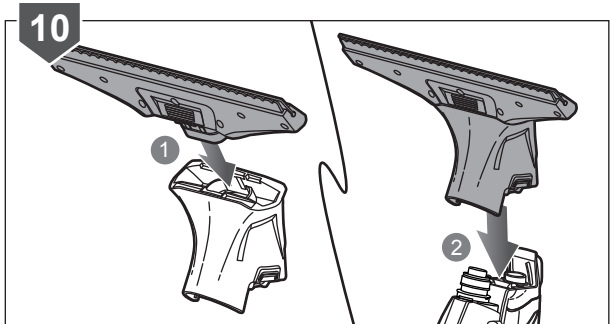
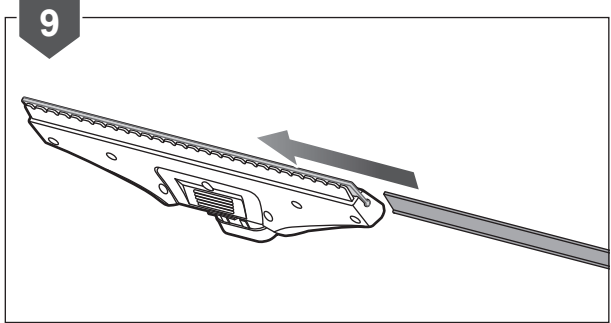
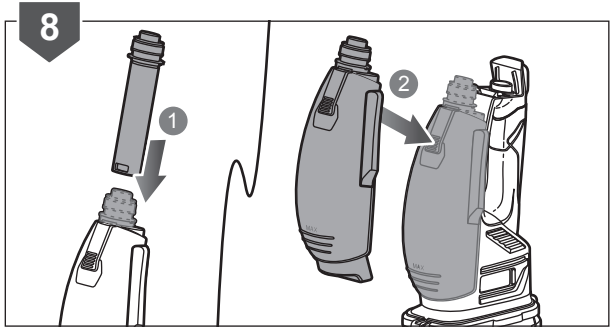

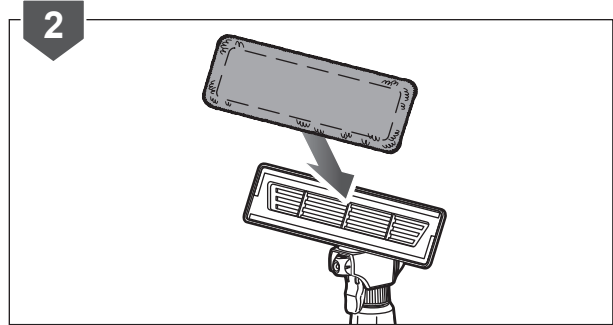
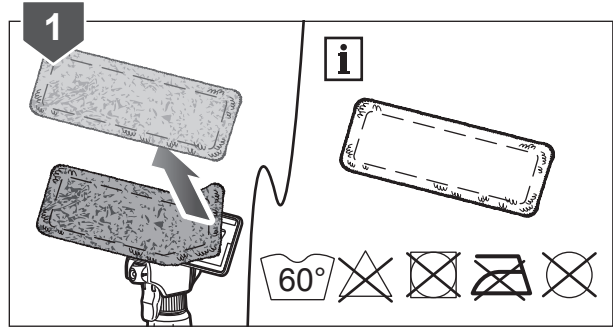
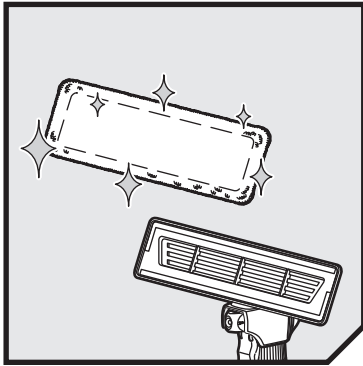

## PRODUCT SPECIFICATIONS

Window vacuum	
Model	R18WV
Voltage	18 V
Air flow volume	0.36 m <sup>3</sup> / min
Liquid container capacity	70 ml
Spray bottle capacity	256 ml
Ingress protection	IPX4
Weight	
Window vacuum - excluding battery pack	0.82 kg
Spray bottle - including wiping cloth	0.15 kg
Measured sound values determined according to IEC60704:	
A-weighted sound pressure level Uncertainty K	$L_{PA} = 65 \text{ dB(A)}$ 3 dB(A)
A-weighted sound power level Uncertainty K	$L_{WA} = 76 \text{ dB(A)}$ 3 dB(A)

Wear ear protectors.

Imported by:

**Techtronic Industries Australia Pty Ltd**  
31 Gilby Road, Mount Waverley, VIC 3149  
Melbourne, Australia

**Techtronic Industries N.Z. Limited**  
2 Landing Drive, Mangere  
Auckland, 2022, New Zealand

*RYOBI is a trademark of Ryobi Limited,  
and is used under license.*