



HERITAGE RANGE SQUARE ELEVATED PLANTER

SM : 400mm (L) 400mm (W) 500mm (H)
MED : 600mm (L) 600mm (W) 600mm (H)
LG : 700mm (L) 700mm (W) 700mm (H)

IMPORTANT

ASSEMBLE THIS PLANTER ON A FLAT LEVEL SURFACE

This heritage timber bed is manufactured from the highest quality cypress heartwood. To prevent discolouration over time it is recommended that once assembled the external surfaces are coated with a quality natural oil or stain.

Before filling the bed with soil, ensure it is square and level.

Be aware that this timber product may splinter so it is recommended that protective gloves are worn during assembly.

KIT CONTENTS

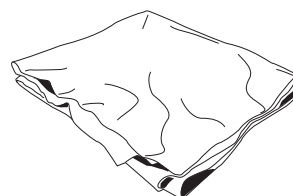
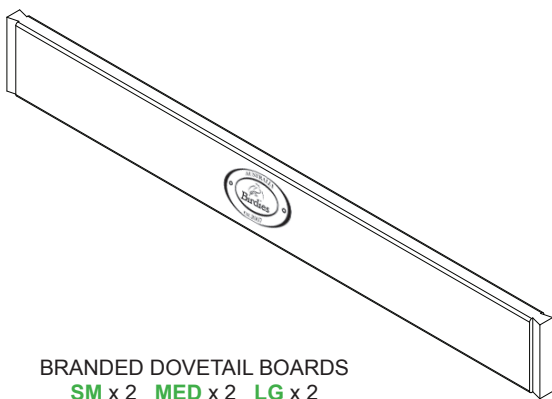
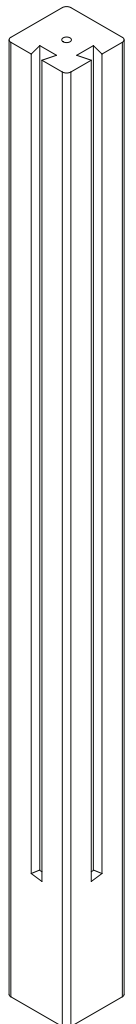
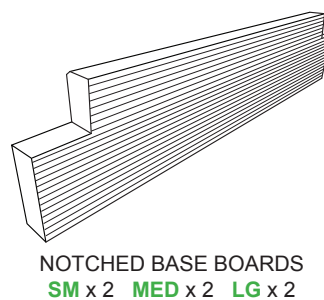
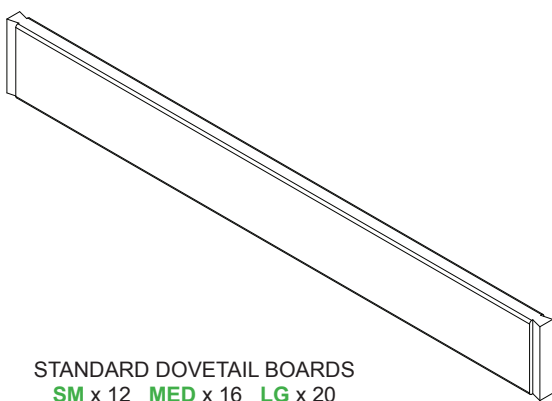
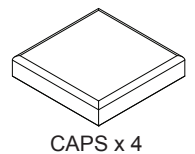
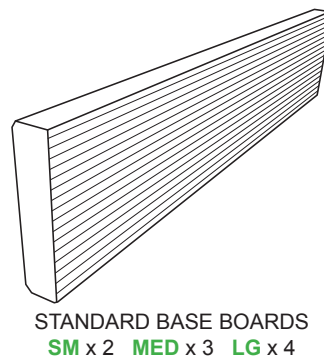
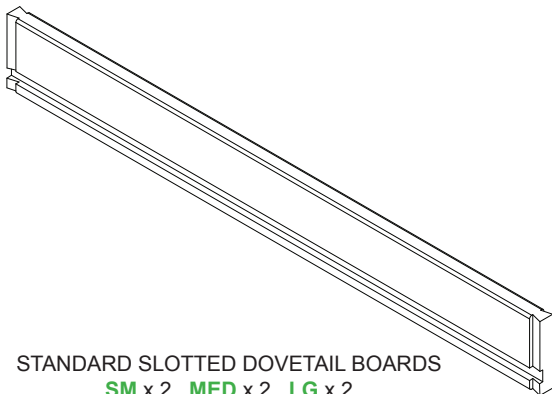

ASSEMBLY

IMPORTANT: THIS PLANTER MUST BE ASSEMBLED ON A FLAT LEVEL SURFACE

STAGE 01

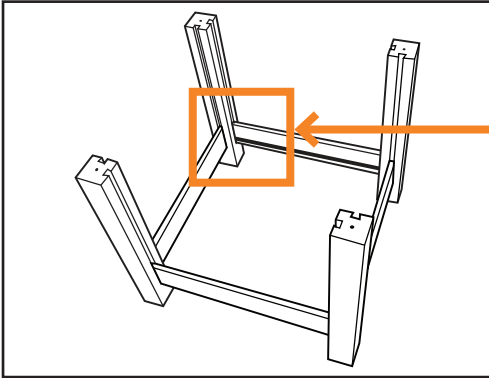

Ensuring the 8mm hole is on the top & the grooved (reeded) side of the timber boards is facing inwards slide in 2 standard & 2 slotted boards opposite to each other.

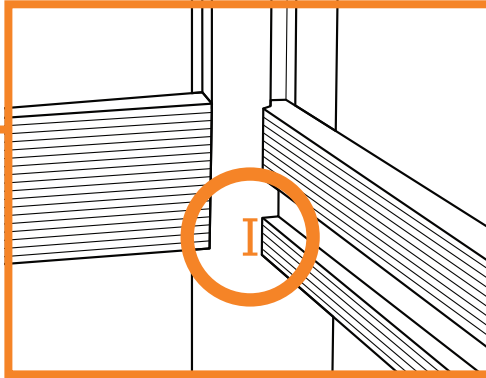

IMPORTANT
The slotted board must go in with the **SMALLER** section of reeded timber **UNDER** the slot.

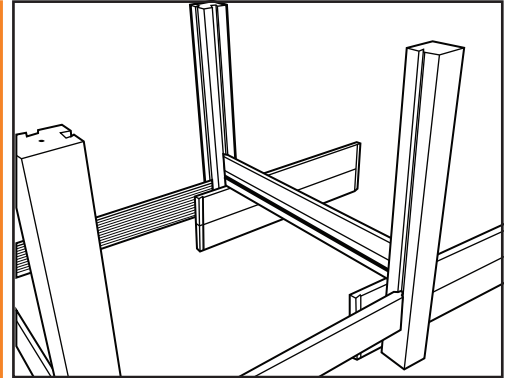

Raise one slotted board resting it on 2 boards, as shown.

STAGE 03

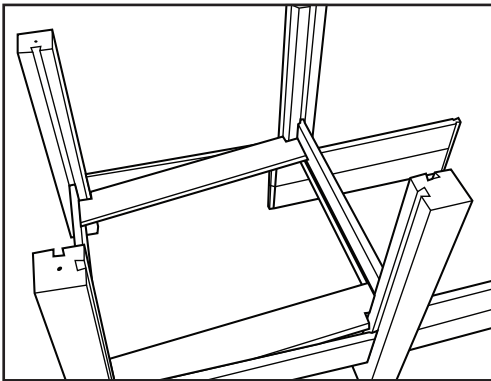

Place in notched boards and remaining base boards. The boards will sit at an angle

STAGE 04

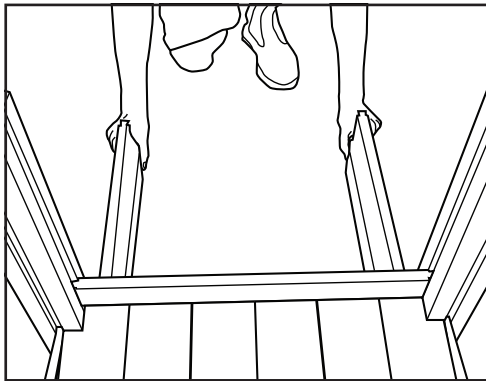

Once the base boards are installed, hold the 2 support boards and pull them out equally, this will lock the base in.

STAGE 05

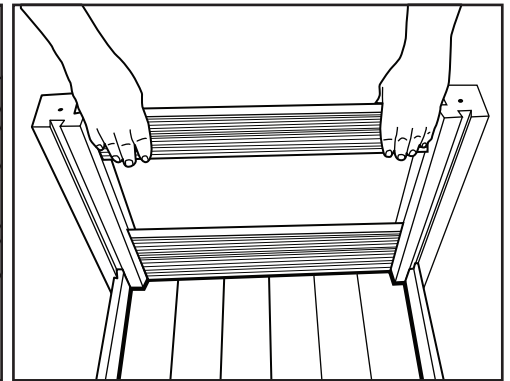

Slide in the remaining boards ensuring the branded board is on top. **Please note:** Hold the boards equally allowing the weight of the board to find the correct position.

STAGE 06

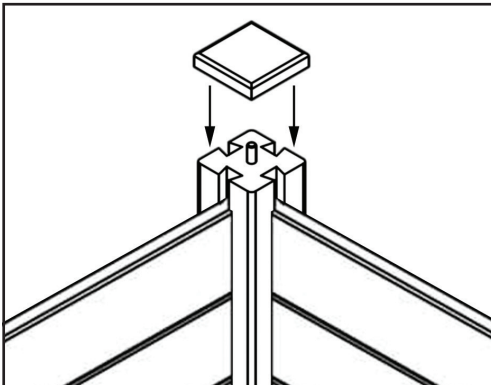

Insert the 4 hardwood dowels into the holes on the top of the posts by hand and then place 4 caps over these dowels. Push down to secure.

Optional: Wood glue can be used to fix the cap in place.

STAGE 07

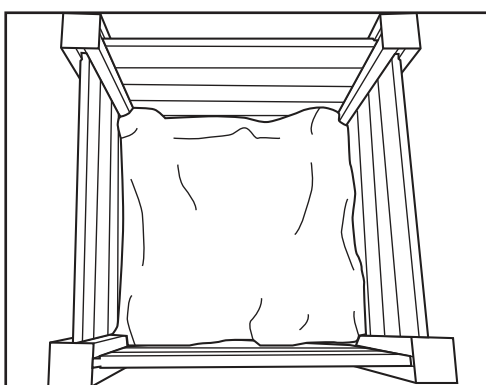

Lay the black geotextile fabric in evenly. Allow excess fabric to lay up the walls. Start filling by placing the soil into each corner of the planter whilst holding the fabric up, this will prevent soil from washing away once filled.

STAGE 08

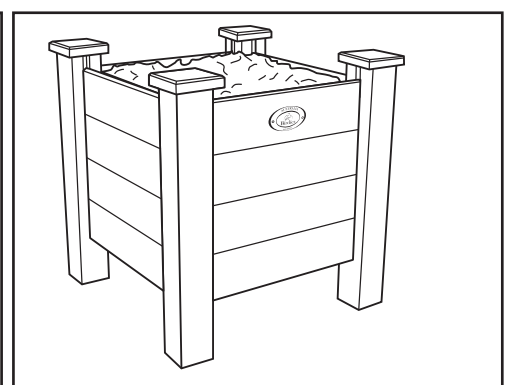

Completed Planter