

THESE INSTRUCTIONS MUST BE READ BEFORE INSTALLATION IS ATTEMPTED. FAILURE TO DO SO MAY COMPROMISE WARRANTY. FOLLOWING INSTALLATION PLEASE LEAVE ALL PAPERWORK WITH CLIENT AS IT CONTAINS IMPORTANT INFORMATION ON HOW TO UNDERTAKE ONGOING CARE FOR YOUR SANITOP PUMP TOGETHER WITH WARRANTY PAPERS.

1. Description - THIS UNIT IS FOR DOMESTIC USE ONLY

The Sanitop is a compact macerator pump designed to receive and pump away sewage waste and water from one standard P-trap WC pan alone or together with one vanity basin.

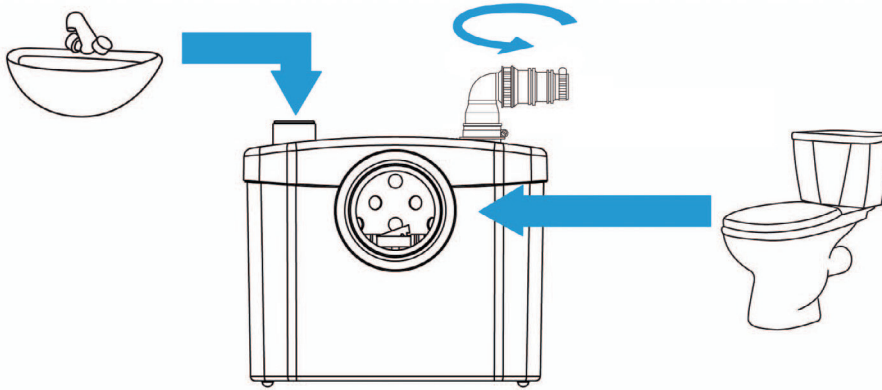

The Sanitop will activate automatically following the flush of your WC or inflow from your vanity fixture.

Please pay particular attention to the following:



Possible danger to personnel



Warning of possible electrical hazard

“ATTENTION” This is a general warning that failure to follow instructions could result in poor functioning of the unit.

This pump benefits from the latest technological innovations concerning soundproofing. To benefit fully from the advantages provided by this new generation of appliances, it is important to comply with the installation instructions in section 5, 6 and 7.

2. List of Accessories included

<p>A x1</p>  <p>Discharge elbow</p>	<p>B x4</p>  <p>32 x 55 Hose clip</p>	<p>C x1</p>  <p>25 x 40 Hose clip</p>	<p>D x1</p>  <p>20 x 32 Hose clip</p>
<p>E x1</p>  <p>Inlet Connector</p>	<p>F x1</p>  <p>100mm 90 x 110 Hose clip</p>	<p>G x2</p>  <p>Floor mounting bracket</p>	<p>H x4</p>  <p>Foam feet</p>
<p>I x1</p>  <p>Pan Collar and Cable Tie</p>			

3. Dimensions and overall measurements

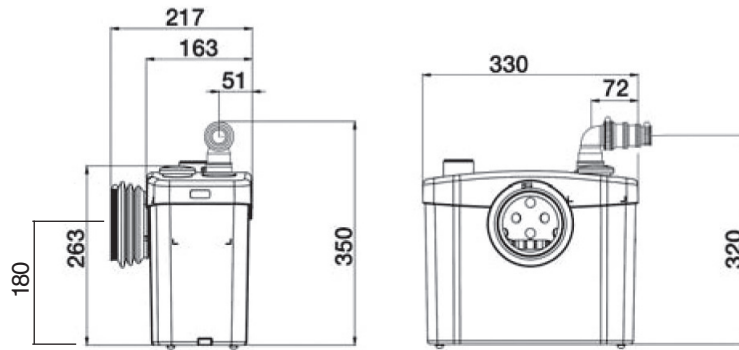

4. Performance curve

USE ONLY Ø 20MM PRESSURE PIPE FOR VERTICAL LIFT

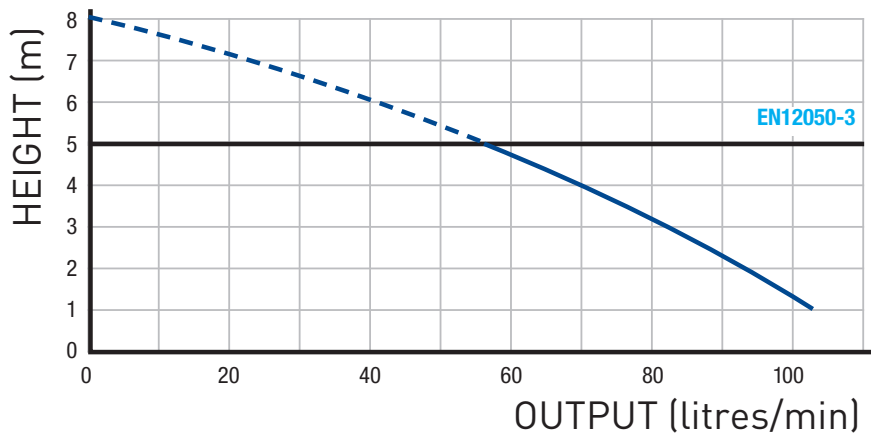

5. Vertical and horizontal pumping parameters

All elbows must be 2 x 45°

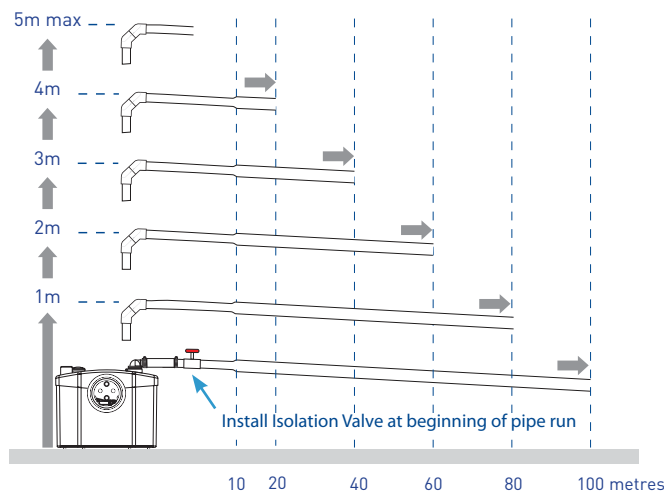

All horizontal pipework requires a minimum of 1:100 fall

Following vertical lift, increase discharge pipe diameter by one size on the Horizontal run to Sewer or vent connection.

N.B. VERTICAL LIFT MUST PRECEDE HORIZONTAL RUN

6. Installation

TO BE UNDERTAKEN BY A REGISTERED PLUMBER IN CONJUNCTION WITH: AS3500 10:10

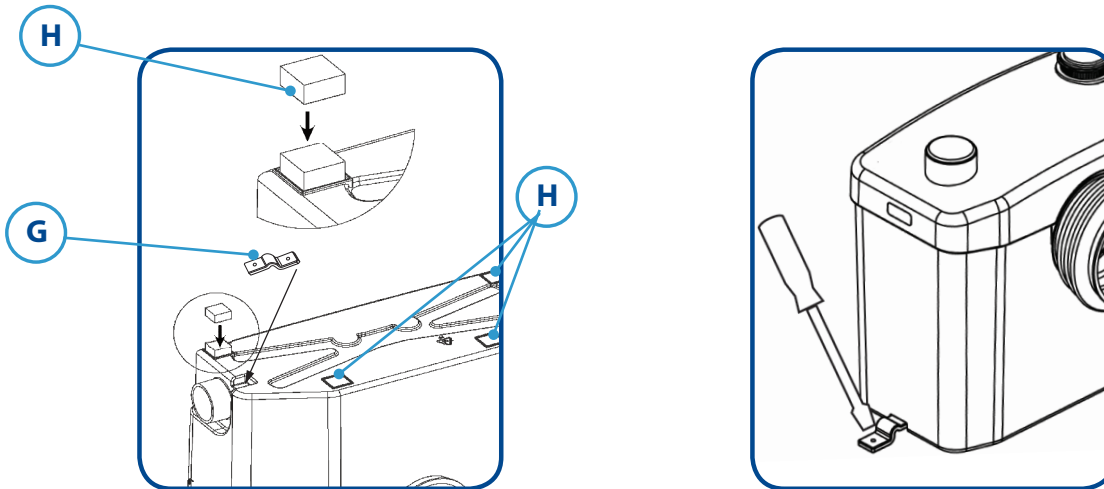

- The Sanitop should be installed to allow full access in the event that servicing and or removal is necessary.
- The Sanitop is supplied with floor mounting lugs and foam feet to minimise vibration and to prevent possible movement during operation.
- The Sanitop must be coupled directly to the spigot (outlet) of the P-trap WC pan.
- The Sanitop must be located on the same ground or floor level to that of the WC pan, do not locate in a Pit or in-ground opening

Connections - Incoming waste water

- All pipework (32/40mm) from a vanity fixture running into the Sanitop must have a constant grade of 1:40.
- The inlet port for a Vanity basin connection is located on top of the Sanitop lid.
- If using the lid port use a stanley blade or hack-saw to remove the very top of the port to allow connection.
- Use rubber connectors and pipe clips (supplied) to make secure connections. Ensure connectors are facing in the right direction before securing. See diagram **E** on page 1.

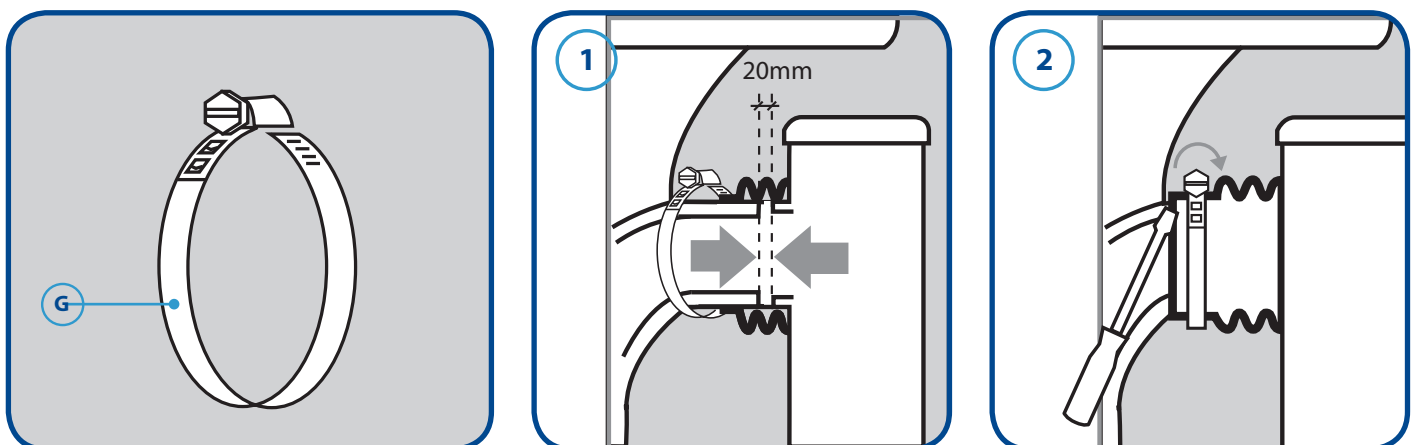

- Position the pump so that it is not in contact with a partition or wall of the room ensuring that the foam feet are attached to the underside of the pump.
- Place the WC pan on a level surface.
- Apply soapy water to the WC spigot and position the pan to the pump, ensuring that there is a 20mm gap between them. The reason for this is two-fold **1.** If in contact with the pump sound vibration occurs, and **2.** the pump can be removed if service is needed.
- Locate pan collar onto front of the pump, ensuring small diameter opening is secured to the pump using plastic cable tie provided. The other end of the pan collar has a larger opening to allow easier fitting to WC pan outlet (spigot).
- Pull the pan collar over the pan spigot
- Position the metal hose clip (**G**) over the end of the pan collar (Spigot end) and tighten with a screwdriver. Affix plastic cable tie to other end of pan collar.
- Once the pump has been positioned, use 2 screws through the floor mounting brackets to fix it to the floor. (optional)

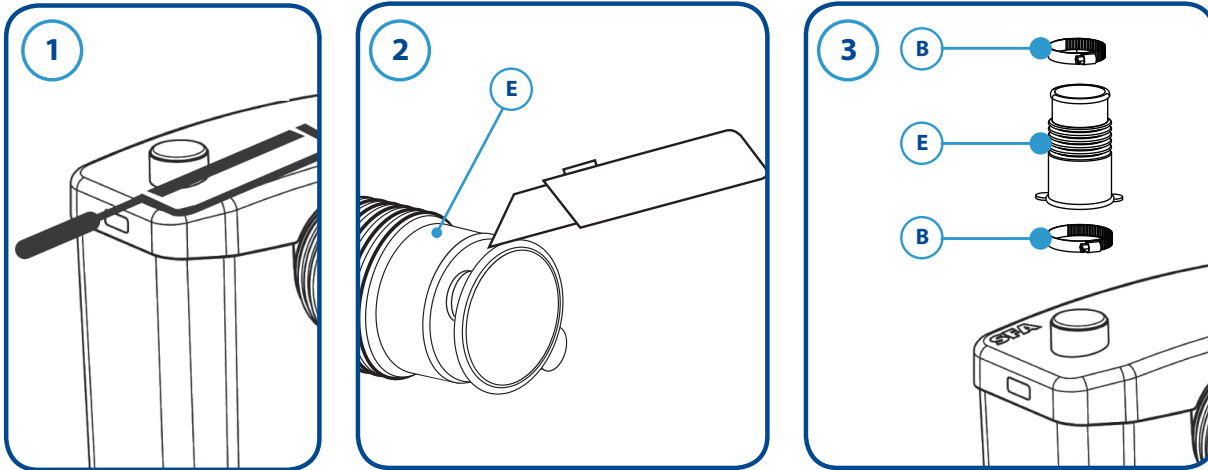

- ① To use the top entry, use a sharp knife or hacksaw to cut off the top of the spigot.
- ② Use a Stanley knife to cut off the blank end of the rubber inlet connector (E).
- ③ Attach the inlet connector to the top entry using the metal hose clip (B), and use another hose clip (B) to attach to the incoming waste pipe. The small diameter faces the pump lid, the larger diameter accepts incoming waste line.

Connections - Discharge outgoing waste water

Select discharge pipework as follows:-

- Vertical lifts must occur prior to any horizontal runs, except for the initial short run at the pump connection, this should be NO MORE than 300mm in length.
- Only ONE vertical lift is permitted in the discharge line, all changes of direction in the discharge line MUST be made with 45deg bends rather than 90deg bends.
- For vertical pipework USE ONLY 20mm upvc (pressure pipe)
- Horizontal pipework (following initial vertical lift) can be upgraded by one size to 25mm.
If manifolding more than one pump, sizing should be in line with fixture loading requirements.
- Once selection has been made, insert discharge elbow (supplied) into the rubber discharge pipe protruding from lid of the Sanitop, trim rubber connector to size and make connection between discharge elbow and upvc discharge pipe.
- Before securing all connections connect a PVC Ball Valve in the upvc pipework as near to the beginning of the discharge line as possible.
- Do NOT install a Non Return Valve (NRV) in the discharge line as the discharge elbow (supplied) incorporates an inbuilt nrv.
- All horizontal pipework that follows initial vertical lift must run with a constant Downhill gradient of 1:100 MIN (or better) to eventual sewer or vent connection.
- Connection to sewer or vent stack can be made via a 45deg junction or boss-strap fitting.
- If running your discharge pipe-work below the floor level on which the pump is located ensure you install an Air Admitance Valve (AAV) at the highest point of the pipework, this will eliminate the effect of Syphonage.

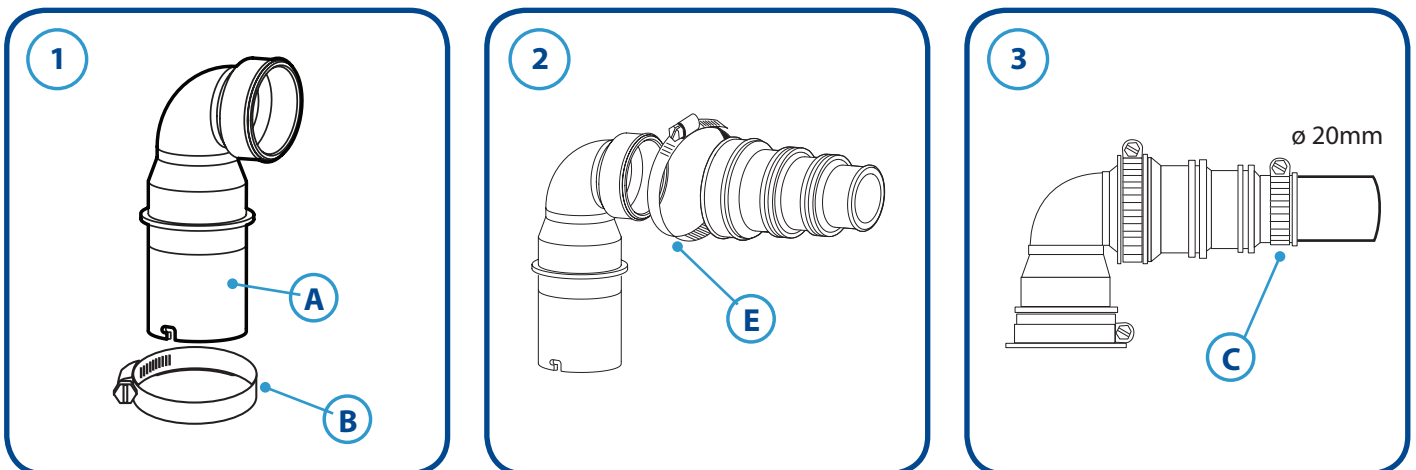

- ① Insert the elbow (A) into the rubber discharge pipe that rises up through the lid and turn it clockwise to the direction required and secure with steel hose clip (B). Lubricate with soapy water or similar to make insertion easier.
- ② Attach the rubber step down reducer to the discharge elbow and secure with steel hose clip (E).
- ③ Connect to the other end to 20mm uPVC pressure pipe, using steel hose clip (C).

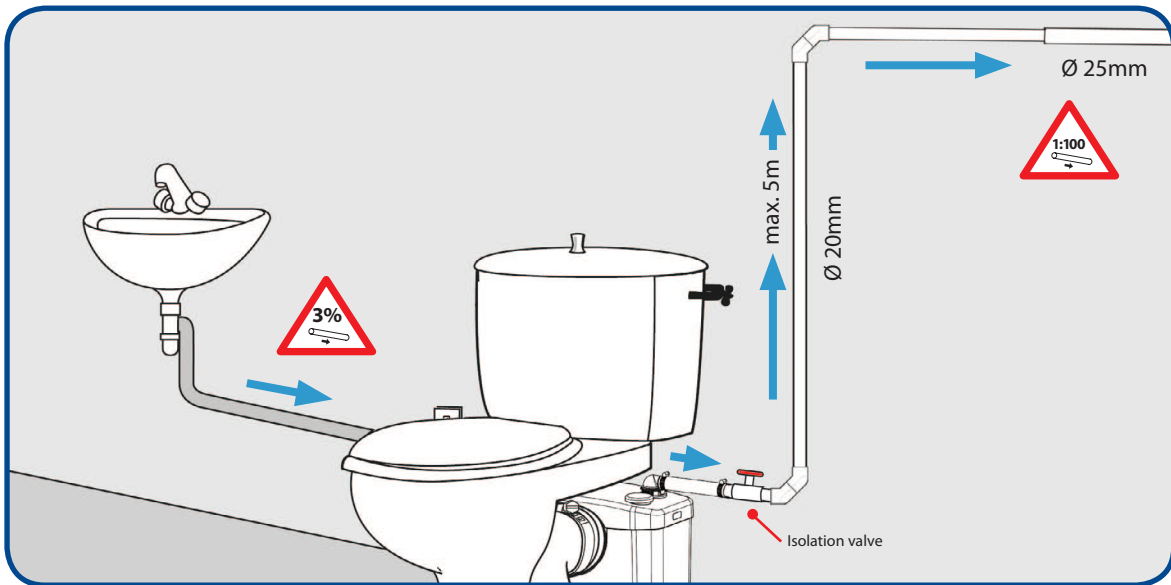
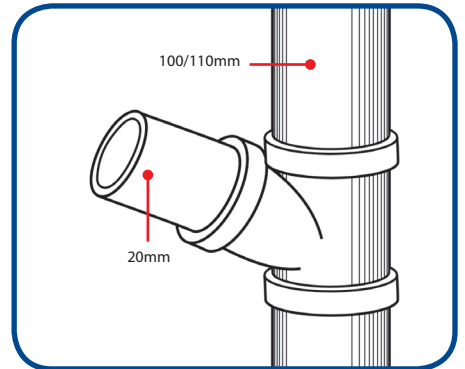
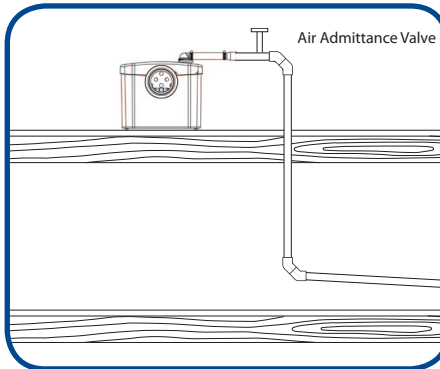
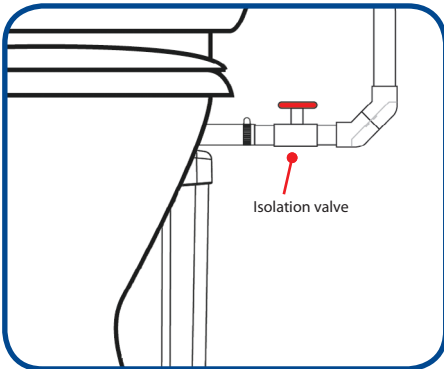
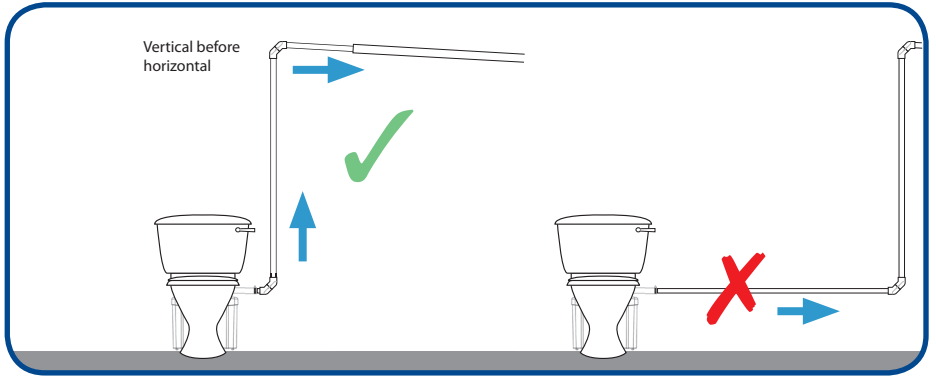
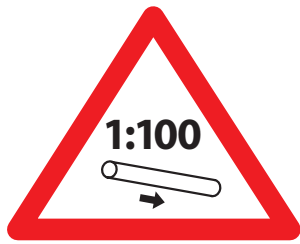

Connections - Venting

- Where possible venting should always be made in a manner consistent with common plumbing practice venting requirements referred to in Australian Standards AS 3500 10:10 & 6:7:4.
- You can use suitable pvc pipe or plastic hose to run the vent, either to the open atmosphere or to an existing vent stack located nearby.
- However if this is not possible, the Sanitop is supplied with a carbon filter pod and covering cap, periodical replacement of this filter pod is recommended approximately every 12 months.

7. Electrical connection

TO BE UNDERTAKEN BY A REGISTERED ELECTRICAL CONTRACTOR IN CONJUNCTION WITH : AS/NZS 3000.2007



The electrical installation should be carried out by a registered electrician.

The Sanitop pump is equipped with a 3 core electrical cable which contains Earth Active and Neutral wires, it has a three pin moulded plug attachment. All wires in this cable are colour coded in accordance with International colour coding ie BROWN - ACTIVE (LIVE), BLUE - NEUTRAL, GREEN / YELLOW - EARTH.

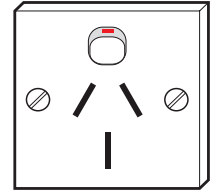

- All wiring connections and GPO locations must conform to AS/NZS 3000:2007 requirements.
- Supply must be protected via a 30mA RCD rated at 16amps, located at the switchboard.
- The Sanitop requires a 240V single phase 50 Hz AC power supply
- If a decision is made to hard wire, in the event that servicing is required then cost to disconnect and re-connect will be at consumers expense.

8. Commissioning the SANITOP pump

BEFORE COMMISSIONING THE PUMP MAKE SURE ALL CONNECTIONS ARE SECURE AND WATER-TIGHT

Once ALL connections are secure and before you switch the power on, press the full flush button on your cistern and allow water to enter the pump, this allows the pump to Prime. Once flush is complete switch the power to the pump ON. Your pump should immediately activate and begin discharging into the discharge pipe system. Initial run time is normally between 5 -10 secs. Duration of run time is generally determined by the length of travel in the pump-out line and type of waste, Pump operation will shut down after this time. Should the pump continue running for longer than the recommended time, an installation or manufacturing problem may exist, immediately contact SANIFLO on 03 9543 3891 and speak with a tech. support t person, they will be only too happy to assist.

9. Approvals

The Sanitop pump conforms to Australian and New Zealand standards AS/NZS and Watermark approvals.

A lifting plant for waste water containing faecal matter and for limited applications, and to European directives and standards applicable to Electrical and electromagnetic compatibility.

Sanitop®

Société Française d'Assainissement

EN 12050-3

LA01-x10

220 - 240 V - 50 Hz -550 W - IP44 2.9A - $\frac{1}{2}$ - 5.4 KG



10. Care and use

DO NOT... dispose of sanitary materials, plastics, wood, solvents, paints, turps, caustic acid, or other corrosive acids or cleaners.

DO NOT... dispose of hot water in excess of 40° C.

DO NOT... use Blu Loo or similar products with your Sanitop as this may cause the pump to cavitate. Cavitation occurs when there is an excessive build of foam or froth from detergents; this may cause motor damage.

DO... dispose of organic matter ie faeces and WC paper (with a full flush) and waste water ONLY.

DO... periodically clean the Sanitop with a basic household detergent cleaner ie domestos, pine o clean or actizyme.

DO... consider calling a Service agent, if you experience operational problems at any time, eg pump sounds different than it did during previous operation, sooner rather than later.

NOISE LEVELS

All Sani pumps (domestic rated) conform to the National Code of Practice for Noise Management and Protection of Hearing in a workplace or domestic environs (NOHSC 2004-2009)

All Saniflo grey water and macerator pumps are not in themselves very noisy and the sound of operation is generally not invasive. However, noise levels can be increased/amplified due to sympathetic resonance from stud partitions, some floors and tight locations.

Example - decibel comparison

- People conversation (normal) 60-70 db
- Sanipumps (domestic) Max 65 db
- Toilet cistern flushing 75 db
- Vacuum cleaner 80 db

11. Servicing

Periodical servicing may be required, depending on your usage cycle. On average we would recommend that a service be undertaken every 2 years or alternatively if you believe that your Sanitop is not functioning as it has been, then give our Technical department a call to obtain details of your nearest Service Agent.

Saniflo Technical support can be contacted on 1300 554 779.

12. Warranty

A 2 Yr Manufacturers Warranty applies to your Sanitop pump this commences from the date of purchase and is subject to CORRECT INSTALLATION and CORRECT USAGE. Any failure or motor burn-out attributed to incorrect installation or consumer misuse is NOT covered under this Warranty.

13. Fault Finding / Remedies

For the most part, any inconsistencies in the operation of the unit will be minor and easily rectified. Please refer to the chart below. **If the problem cannot be easily remedied in this way, please call us on 1300 554 779.**



IN ALL CASES, YOU MUST DISCONNECT THE MACERATOR FROM THE POWER SUPPLY.

ALL WORK INVOLVING DISMANTLING OF THE APPLIANCE MUST BE CARRIED OUT BY AN APPROVED REPAIR AGENT.

SYMPTOMS	PROBABLE CAUSES	REMEDIES
<ul style="list-style-type: none"> The unit stops 	<ul style="list-style-type: none"> An object is blocking the blades The unit has been running for too long and the (self re-setting) thermal cut out has engaged 	<ul style="list-style-type: none"> Call approved service engineer. The unit will reset itself.
<ul style="list-style-type: none"> The motor intermittently activates 	<ul style="list-style-type: none"> The connected fixtures are dripping The non-return valve is faulty Cistern is leaking 	<ul style="list-style-type: none"> Check the installation upstream Clean or replace the non-return valve (externally mounted) Call plumber to replace flush pipe seal
<ul style="list-style-type: none"> The water in the WC pan goes down very slowly and is pumped away in bursts 	<ul style="list-style-type: none"> The air vent (under carbon filter) is clogged up The WC pan is partially blocked 	<ul style="list-style-type: none"> Clear the air vent. Clear the WC pan
<ul style="list-style-type: none"> The motor operates normally, but continues to run for a long time 	<ul style="list-style-type: none"> The length or height of the installation is over the specification, or there are too many bends/elbows The pump chamber is blocked An electrical component has failed 	<ul style="list-style-type: none"> Check the installation Call approved service engineer
<ul style="list-style-type: none"> The motor does not activate 	<ul style="list-style-type: none"> The electrical power supply is not active The motor or the control system is defective 	<ul style="list-style-type: none"> Restore the electrical supply Call approved service engineer
<ul style="list-style-type: none"> The motor emits a rattling or crunching sound, hums, but does not run 	<ul style="list-style-type: none"> Foreign object in the pump Problem with the motor or the control system 	<ul style="list-style-type: none"> Call approved service engineer

14. Parts

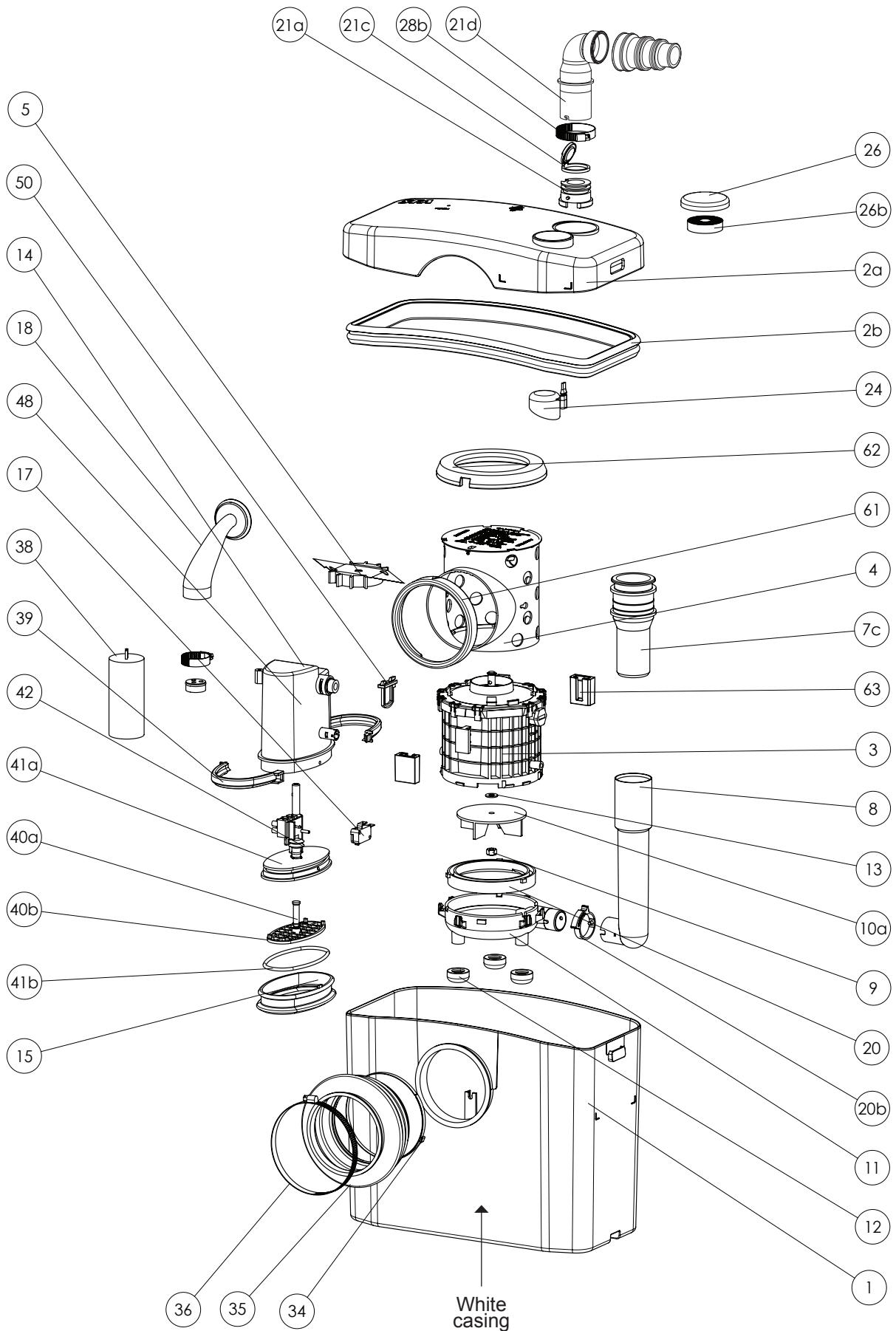

15. Ten golden rules for correct installation

