

Operating Instructions

XTRP-420

XU1

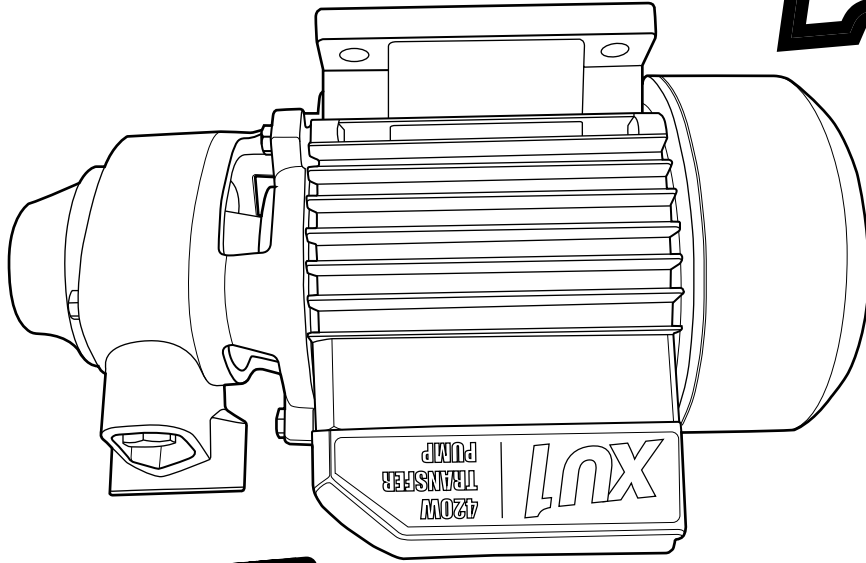

**12 MONTHS HOME USE
REPLACEMENT WARRANTY**

**420W
Transfer
Pump**

XU1 Power tools

1-23 Letcon Drive, Bangholme, Victoria, Australia 3175

Telephone: 1800 069 486

Website: www.xuone.com.au

SAFETY INSTRUCTIONS

Electrical safety



WARNING! When using mains-powered tools, basic safety precautions, including the following, should always be followed to reduce risk of fire, electric shock, personal injury and material damage. Read the whole manual carefully and make sure you know how to switch the tool off in an emergency, before operating the tool.

Save these instructions and other documents supplied with this tool for future reference.

The electric motor has been designed for 230V and 240V only. Always check that the power supply corresponds to the voltage on the rating plate.

Note: The supply of 230V and 240V on XU1 tools are interchangeable for Australia and New Zealand.

This pump is earthed in accordance with AS/NZS 60335-2-41.

If the supply cord is damaged, it must be replaced by an electrician or a power tool repairer in order to avoid a hazard.

Note: The power outlet used for the water pump must be protected by a 30mA residual current device or earth leakage circuit breaker. If the power outlet is external, ensure that it is weather proof. The water pump has a built-in thermal protection overload switch. The water pump stops if an overload occurs. The motor restarts automatically after it has cooled down.

Using an Extension Lead

Always use an approved extension lead suitable for the power input of this tool. Before use, inspect the extension lead for signs of damage, wear and ageing. Replace the extension lead if damaged or defective.

When using an extension lead on a reel, always unwind the lead completely. Use of an extension lead not suitable for the power input of the tool or which is damaged or defective may result in a risk of fire and electric shock.

Do not allow plug to enter water.

Description of symbols



Read instruction manual



Warning



R.C.M. Regulatory compliance mark

V

Volts

Hz

Hertz

~

Alternating current

W

Watts

/min

Revolutions, reciprocations or strokes per minute

no

No load speed

Hp

Horse power

°C

Degrees Celsius

p/hr

Per hour

kpa

Pressure rating (kilopascals)

Bar

Pressure rating

L

Litres

F

Insulation class

PVC

Polyvinyl chloride

IPX4

Ingress protection from water

Caring for the environment



Power tools that are no longer usable should not be disposed of with household waste but in an environmentally friendly way. Please recycle where facilities exist. Check with your local council authority for recycling advice.



Recycling packaging reduces the need for landfill and raw materials. Reuse of recycled material decreases pollution in the environment. Please recycle packaging where facilities exist.

Check with your local council authority for recycling advice.

General Power Tool Safety Warnings



WARNING! Read all safety warnings and all instructions. Failure to follow the warnings and instructions may result in electric shock, fire and/or serious injury.
Save all warnings and instructions for future reference. The term "power tool" in all of the warnings refers to your mains-operated (corded) power tool or battery-operated (cordless) power tool.

1) Work area safety

a) Keep work area clean and well lit. Cluttered and dark areas invite accidents.

b) Do not operate power tools in explosive atmospheres, such as in the presence of flammable liquids, gases or dust.

Power tools create sparks which may ignite the dust or fumes.

c) Keep children and bystanders away while operating a power tool. Distractions can cause you to lose control.

2) Electrical safety

a) Power tool plugs must match the outlet. Never modify the plug in any way. Do not use any adapter plugs with earthed (grounded) power tools. Unmodified plugs and matching outlets will reduce risk of electric shock.

b) Avoid body contact with earthed or grounded surfaces such as pipes, radiators, ranges and refrigerators. There is an increased risk of electric shock if your body is earthed or grounded.

c) Do not expose power tools to rain or wet conditions. Water entering a power tool will increase the risk of electric shock.

d) Do not abuse the cord. Never use the cord for carrying, pulling or unplugging the power tool. Keep cord away from heat, oil, sharp edges or moving parts. Damaged or entangled cords increase the risk of electric shock.

e) When operating a power tool outdoors, use an extension cord suitable for outdoor use. Use of a cord suitable for outdoor use reduces the risk of electric shock.

f) If operating a power tool in a damp location is unavoidable, use a residual current device (RCD) protected supply. Use of an RCD reduces the risk of electric shock.

3) Personal safety

a) Stay alert, watch what you are doing and use common sense when operating a power tool. Do not use a power tool while drugs, alcohol or medication. A moment of inattention while operating power tools may result in serious personal injury.

b) Use personal protective equipment. Always wear eye protection. Personal protective equipment such as dust mask, non-skid safety shoes, hard hat, or hearing protection used for appropriate conditions will reduce personal injuries.

c) Prevent unintentional starting. Ensure the switch is in the off-position before

connecting to power source and/or battery pack, picking up or carrying the tool. Carrying power tools with your finger on the switch or energising power tools that have the switch on invites accidents.

d) Remove any adjusting key or wrench before turning the power tool on. A wrench or a key left attached to a rotating part of the power tool may result in personal injury.

e) Do not overreach. Keep proper footing and balance at all times. This enables better control of the power tool in unexpected situations.

f) Dress properly. Do not wear loose clothing or jewellery. Keep your hair, clothing and gloves away from moving parts. Loose clothes, jewellery or long hair can be caught in moving parts.

g) If devices are provided for the connection of dust extraction and collection facilities, ensure these are connected and properly used. Use of dust collection can reduce dust-related hazards.

4) Power tool use and care

a) Do not force the power tool. Use the correct power tool for your application.

The correct power tool will do the job better and safer at the rate for which it was designed.

b) Do not use the power tool if the switch does not turn it on and off. Any power tool that cannot be controlled with the switch is dangerous and must be repaired.

c) Disconnect the plug from the power source and/or the battery pack from the power tool before making any adjustments, changing accessories, or storing power tools. Such preventive safety measures reduce the risk of starting the power tool accidentally.

d) Store idle power tools out of the reach of children and do not allow persons unfamiliar with the power tool or these instructions to operate the power tool.

Power tools are dangerous in the hands of untrained users.

e) Maintain power tools. Check for misalignment or binding of moving parts, breakage of parts and any other condition that may affect the power tools operation. If damaged, have the power tool repaired before use. Many accidents are caused by poorly maintained power tools.

f) Keep cutting tools sharp and clean.

Properly maintained cutting tools with sharp cutting edges are less likely to bind and are easier to control.

g) Use the power tool, accessories and tool bits etc. in accordance with these instructions and in the manner intended for the particular type of power tool, taking into account the working conditions and the work to be performed.

Use of the power tool for operations different from those intended could result in a hazardous situation.

5) Service

a) Have your power tool serviced by a qualified repair person using only identical replacement parts. This will ensure that the safety of the power tool is maintained.

Pump Safety Warnings



WARNING! This product is intended for pumping water in a Home Domestic application. Do not use it for corrosive, abrasive, explosive or dangerous liquids. Fluids other than water will damage the water pump and/or create a fire hazard. Failure to follow all instructions listed below may result in electric shock, fire and/or serious injury.



WARNING! This product is not suitable for use with drinking (potable) water.

This appliance is not intended for use by person (including children) with reduced physical, sensory or mental capabilities, or lack of experience and knowledge, unless they have been given supervision or instruction concerning use of the appliance by a person responsible for their safety.

Children should be supervised to ensure that they do not play with the appliance.

- **Ensure the water pump is disconnected from mains power when installing.**
- **Do not install or operate the water pump in an explosive environment or near flammable material.**
- **Do not operate the water pump without liquid.**
- **Do not run the water pump dry.**



WARNING! The water pump together with associated pipe work operate under pressure. Do not disconnect water pump or pipe work until internal pressure has been released. Failure to do this could result in personal injury and damage to property.

- **Avoid inserting hands into the inlets/outlets of the water pump while it is connected to power.**
- **Before using the water pump, always inspect it visually. Do not use the pump if it is cracked and/or damaged. If the water pump is damaged, contact XU1 customer service.**
- **The water pump has a built-in thermal protection overload switch. The water pump stops if an overload occurs. The motor restarts automatically after it has cooled down.**
- **The pump must not be used when people are in the water.**
- **Never work or perform maintenance on the pump without first making sure it has been disconnected from the mains power.**
- **Pollution of the liquid could occur due to leakage of lubricants.**

Important: Avoid inserting hands into the mouth of the pump if it is connected to the mains.

The electrical connection must always be made in a dry area. Make sure that electrical connections are protected from inundations.

Protect the plug and the power cable from heat, oil or sharp edges.

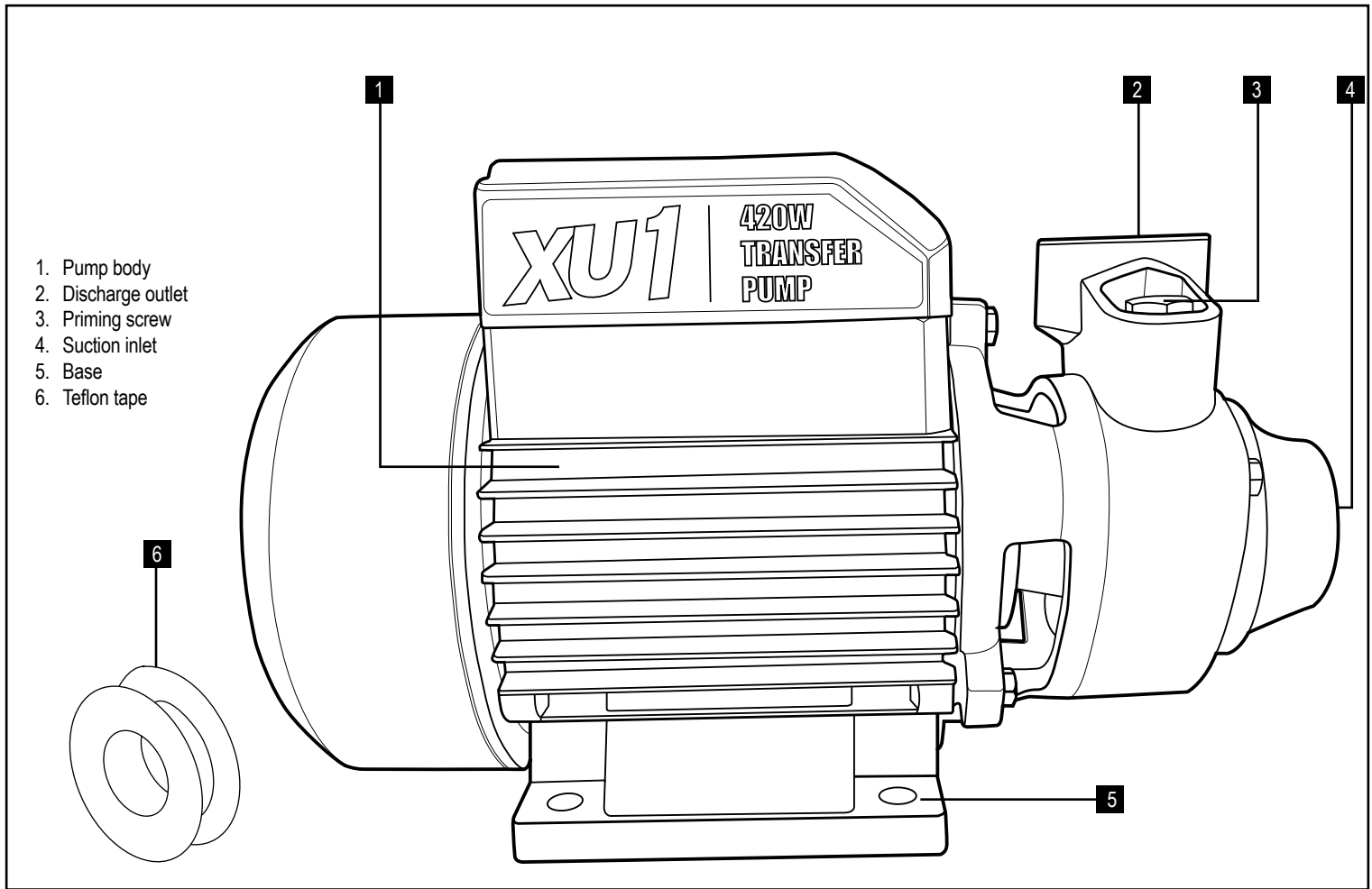

1. Pump body
2. Discharge outlet
3. Priming screw
4. Suction inlet
5. Base
6. Teflon tape

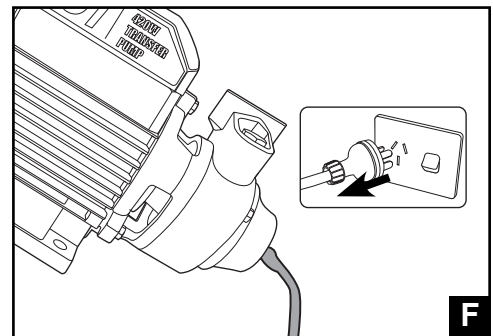
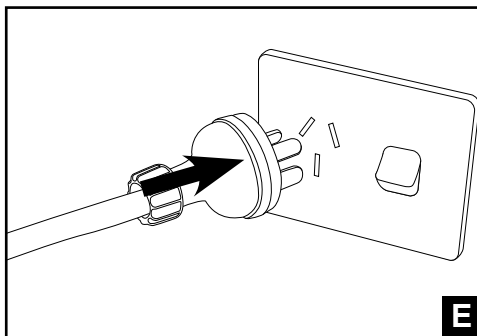
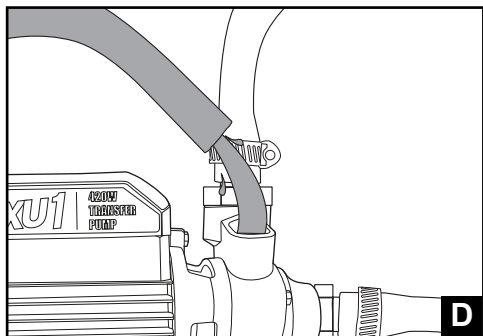
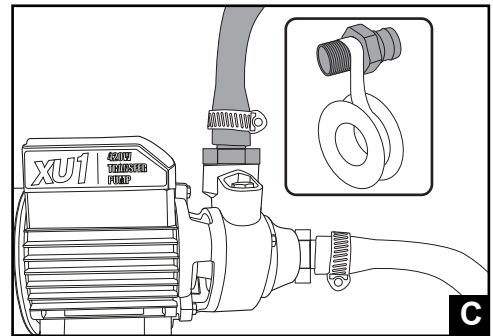
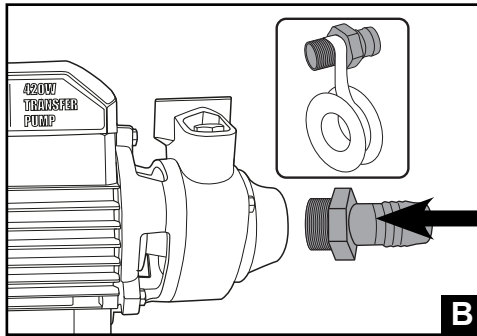
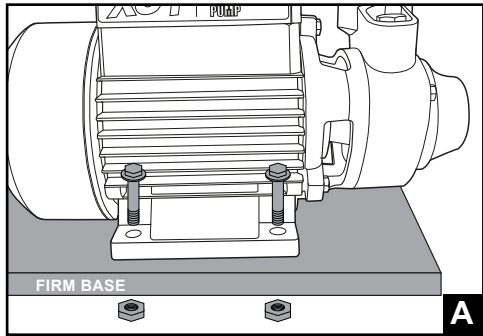

SPECIFICATIONS

| | |
|--------------------------------|--------------|
| Wattage: | 420W |
| Max. Flow Rate: | 1,900 l/h |
| Max. Suction Height: | 0m |
| Max. Total Head: | 33m |
| Inlet: | Ø25.4mm (1") |
| Outlet: | Ø25.4mm (1") |
| Max. Delivery Pressure: | 3.30 bar |
| Water Temp.: | 1°C - 35°C |
| IP Rating: | IPX4 |
| Weight: | 5.5kg |

USING YOUR PUMP



WARNING! Before use always read the safety instructions given on the rear of this manual. Failure to comply with the precautions stated could lead to a fire, serious injury or death.

Setting Up



WARNING! Ensure the pump is disconnected from the power supply before performing any of the following operations.

This transfer pump is designed for pumping clean water in the house and garden. It is ideal for drawing water from pools, spas, rainwater tanks and providing irrigation and watering of green areas, vegetable beds and gardens.

Your pump requires no assembly before use other than the connection of suitable inlet/outlet hose or pipe adaptors (not included).

Positioning the pump

The device must be placed on a horizontal, level surface that is sufficiently capable of supporting the total weight of the device when filled with water.

Four mounting recesses allow for fixing the base to the mounting surface (bolts not supplied), **fig. A**.

NOTE: The installation site must be well ventilated and protected from the effects of weather.

NOTE: When operating indoors you must ensure that there is a drain in the floor or a mechanism to prevent leakage.

Connecting to the suction inlet

The inlet allows for a 25.4mm (1") supply line to be connected.

NOTE: The Ozito TPIK-025 Tank to pump installation kit is available from Bunnings stores.

1. Teflon tape is required on threads to ensure a water tight seal and prevent any leakage. Wind Teflon clockwise on fittings.
2. Remove the plastic protection cover from the suction inlet.
3. Insert a 1" male threaded hose adaptor (not included). Tighten firmly with a spanner (not included) **fig. B**.

4. Securely attach the input hose or pipe (not included) to the other end of the adaptor. Ensure you have the correct diameter hose or pipe that is compatible with your water drawing source.

NOTE: The suction pipe should have an internal diameter of at least 25.4mm (1"); it must be kink resistant and suitable for pump use. Ensure the input hose or pipe is not restricted in any way.

CAUTION! The input hose or pipe should be low enough in the water to ensure that if the water level falls, the pump will not run dry. Ensure that this is checked when in operation.

Connecting to the discharge outlet

The outlet allows for a 25.4mm (1") delivery line to be connected and is capable of a maximum head of 33m.

1. Teflon tape is required on threads to ensure a water tight seal and prevent any leakage. Wind Teflon clockwise on fittings.
2. Remove the plastic protection cover from the discharge outlet.
3. Insert a 1" male threaded hose adaptor (not included). Tighten firmly with a spanner (not included).
4. Securely attach the output hose or pipe (not included) to the other end of the adaptor. Ensure you have the correct diameter hose or pipe that is compatible with your water discharge application. **fig. C**

NOTE: The discharge hose or pipe you are using must have a minimum diameter of 19mm (3/4").



WARNING! Risk of injury! If the components are not compression-proof or if they are improperly installed, the pressure line could burst during operation.

OPERATION

Priming the Pump

CAUTION! The pump should be filled with water after each new connection or if water loss or air intake has occurred. Extended operation without a water refill will damage the pump.

Priming the pump is required to purge air from the hose. Don't operate the pump without it being primed.

1. Ensure the pump is switched off at the mains power.
2. Remove the priming plug from the top of the pump housing by turning anti-clockwise.
3. Fill the pump completely with water. Ensure the pump and inlet pipe or hose are full. Replace the priming plug **fig. D**.



WARNING! Danger due to electrical shock! Do not operate the device in wet surroundings!

Starting



WARNING! The pump must be used with residual current device rated 30mA or less.

Insert the power plug into the mains power socket. Where possible avoid using extension cords as this can lead to a voltage drop which may cause power loss and overheating.

1. Switch the device on at the mains plug **fig. E**.
2. Check to make sure that water is coming out.

NOTE: When the pump is fully primed and air is flushed out of the suction cycle, the pump is ready to operate. The pump may take several minutes to fully prime air from the suction line and inside the pump.

If the motor does not start up or the pump does not build up any pressure or if similar faults occur, turn the device off and refer to **TROUBLESHOOTING** section to find a remedy.

CAUTION: The pump must not be allowed to run dry. Sufficient water must be on hand at all times.



WARNING! This product is intended for pumping water in home domestic application. Do not use it for corrosive, abrasive, explosive or dangerous liquids.

Recommended Setup

Position the input hose or pipe so that it rises from the water drawing source to the pump. Where possible, avoid positioning the input hose or pipe higher than the pump, as this would delay the escape of air bubbles from the input hose or pipe and impede the priming process (see section 'Priming the pump' for description on priming the pump).

NOTE: The suction line should be as short as possible, since the conveying capacity decreases as the length of the line increases.

NOTE: A leaking hose or pipe will draw in air and therefore not draw in any water.

NOTE: During the initial set-up, please purge all air from the system via the discharge outlet highest in the system.

RECOMMENDED SET-UP

Connection with tank base level with transfer pump

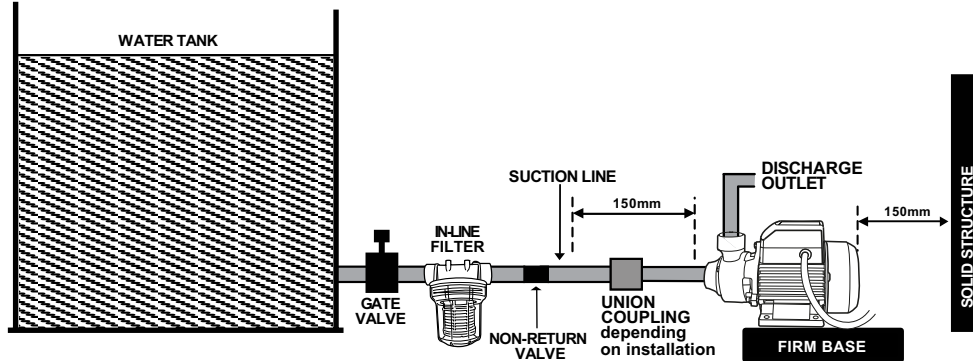

RECOMMENDED SET-UP

Connection with tank base above transfer pump

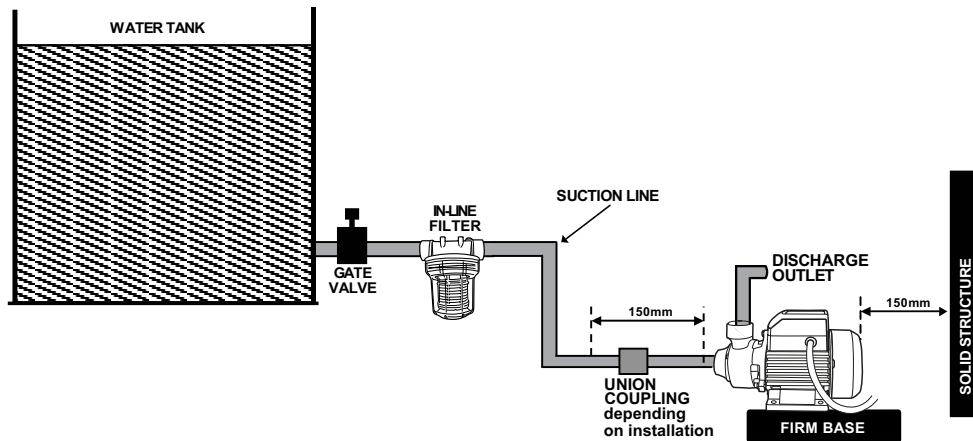

DO NOT

Connection with tank base below transfer pump

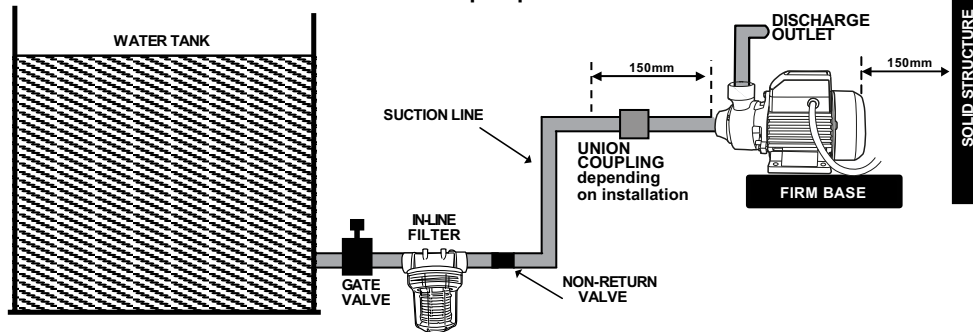

DO NOT

POTENTIAL FOR AIR ENTRAPMENT

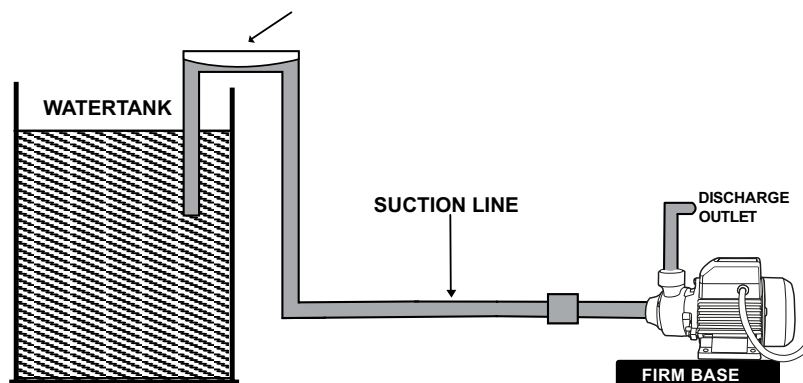

MAINTENANCE



WARNING! Make sure the pump is disconnected from electric power supply before performing maintenance procedures.

Cleaning the Pump Housing

Use a moist cloth to wipe down the pump housing. Allow to dry thoroughly before storing in a dry location that is protected from bad weather conditions.

Storage

If there is danger of frost, dismantle the device and accessories, clean and store them in a place protected from frost.

Draining the Pump

Before moving or storing the pump, the tank will need to be drained of any water using the drain screw.

1. Disconnect the pump from the mains supply.
2. Ensure the gate valve on your water tank is not left open as this will allow water to drain from the water tank.
3. Dismantle the suction and discharge lines.
4. Completely empty the pump by unscrewing the water drain plug **fig. F**.
5. Store the pump in a frost-free room (at least 5°C)

Note: XU1 will not be responsible for any damage or injuries caused by the repair of the tool by an unauthorised person or by mishandling of the tool.

TROUBLESHOOTING

| Problem | Possible Cause | Solution |
|----------------------------------------------------------------------------------|---------------------------------------------------------------------------------------------------------------------------------------------------------------------------------------------------------------------------------------------------------------|------------------------------------------------------------------------------------------------------------------------------------------------------------------------------------------------------------------------------------------------------------------------------------------------------------------------------------------------------------------------------------------------------------------------------------------------------------------------------------------------------------------------------------------------------------------------------------|
| The pump does not start, or pump water | Pump is not connected to the power supply Pump is blocked Pump is not connected to the water supply | Check that the pump is connected to the mains power supply Disconnect the pump from the mains power. Inspect the discharge outlet and filter Ensure the pump is connected to the water supply |
| The pump does not supply water when the motor is running | The pump has not been primed Suction line is leaking The pump is sucking air Pump is blocked Pump is not producing enough pressure Water source does not have enough water The suction height is too high The hose diameter is too small | Fill the pump with water, ensure the suction line and pump are filled with water Check the suction line for leaks and replace hose or pipe if it is damaged or worn Ensure all connections and fittings are secured tightly Disconnect the mains power and check the discharge outlet and filter for any foreign matter Check all parts of the pump and clean Wait until the water source increases so the pump can operate Ensure the suction height is no higher than 0m Ensure the hose diameter is at least 25mm (suction line) and 19mm (discharge line) |
| Tube or piping does not stay on the male thread when water is travelling through | The hose or tubing may be worn or vary slightly with the dimensions | Add a hose clamp to prevent leaks and secure the hose or pipe |
| The pump operates intermittently | There is a water leak in the household plumbing The voltage is out of range Air flow is not allowing the motor to cool The motor is faulty or damaged | Inspect and fix any leaks Supply the pump in accordance with the rating label requirements (230-240V) Ensure the pump is in a well ventilated area Contact Ozito customer service |
| Poor Performance low pressure flow | Faulty suction line The pump has not been primed fully | Check all the suction lines for leaks or any damage. Replace if they are faulty and check that you are using a reinforced hose to prevent the hose from collapsing Fill the pump with water, ensure the suction line and pump are filled with water |

WARRANTY

YOUR WARRANTY FORM SHOULD BE RETAINED BY YOU AT ALL TIMES. IN ORDER TO MAKE A CLAIM UNDER THIS WARRANTY YOU MUST RETURN THE PRODUCT TO YOUR NEAREST BUNNINGS WAREHOUSE WITH YOUR BUNNINGS REGISTER RECEIPT. PRIOR TO RETURNING YOUR PRODUCT FOR WARRANTY. PLEASE TELEPHONE OUR CUSTOMER SERVICE HELPLINE:

Australia 1800 069 486

New Zealand 0508 069 486

TO ENSURE A SPEEDY RESPONSE PLEASE HAVE THE MODEL NUMBER AND DATE OF PURCHASE AVAILABLE. A CUSTOMER SERVICE REPRESENTATIVE WILL TAKE YOUR CALL AND ANSWER ANY QUESTIONS YOU MAY HAVE RELATING TO THE WARRANTY POLICY OR PROCEDURE.

The benefits provided under this warranty are in addition to other rights and remedies which are available to you at law.

Our goods come with guarantees that cannot be excluded at law. You are entitled to a replacement or refund for a major failure and for compensation for any other reasonably foreseeable loss or damage. You are also entitled to have the goods repaired or replaced if the goods fail to be of acceptable quality and the failure does not amount to a major failure.

Generally you will be responsible for all costs associated with a claim under this warranty, however, where you have suffered any additional direct loss as a result of a defective product you may be able to claim such expenses by contacting our customer service helpline above.

1 YEAR REPLACEMENT WARRANTY

Your product is guaranteed for a period of 12 months from the original date of purchase and is intended for DIY (Do It Yourself) use only. If a product is defective it will be replaced in accordance with the terms of this warranty. Warranty excludes consumable parts, for example: O-rings, bearings, seals and gaskets.

WARNING

The following actions will result in the warranty being void.

- Professional, Industrial or high frequency use.
- If the tool has been operated on a supply voltage other than that specified on the tool.
- If the tool shows signs of damage or defects caused by or resulting from abuse, accidents or alterations.
- Failure to perform maintenance as set out within the instruction manual.
- If the tool is disassembled or tampered with in any way.

XU1

Australia/New Zealand (Head Office) 1-23 Letcon Drive, Bangholme, Victoria, Australia 3175