

COMPACT WORKBENCH

1405H x 1100W x 540Dmm

ITEM NO: G0S018

**POWDER
COATED
BLACK**

**200kg
PER SHELF**

SAFETY TIP:

When assembling or installing this product wear protective gloves and eyewear.

Very Important: Unpack the unit and confirm that you have all the parts listed. Assemble the unit on a solid, level surface. Avoid carpet. You will need the assistance of a second person during assembly.
Safety tip: For added safety and support we recommend you fix unit to a wall.
You will need the following: Rubber mallet, Phillips-head screwdriver and adjustable spanner.

Parts List		
	Front Leg 'A'	X 2
	Back Leg Left 'B'	X 1
	Back Leg Right 'C'	X 1
	Long Bracket 'D'	X 4
	Short Bracket 'E'	X 4
	Middle Brace 'F'	X 4
	Peg Board Frame Left 'G'	X 1
	Peg Board Frame Right 'H'	X 1
	Tool Tray 'I'	X 1
	Tool Tray Bracket Left 'J'	X 1
	Tool Tray Bracket Right 'K'	X 1
	Peg Board 'L'	X 1
	Bench Top 'M'	X 1
	Bottom Shelf 'N'	X 1
	Peg Board Hooks	X 20
	Foot Caps	X 4
	Phillips Head Bolts M6*15mm	X 11
	Hex Nuts M6	X 9

NOT TO SCALE

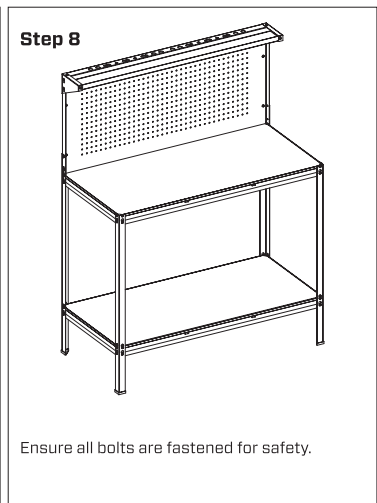
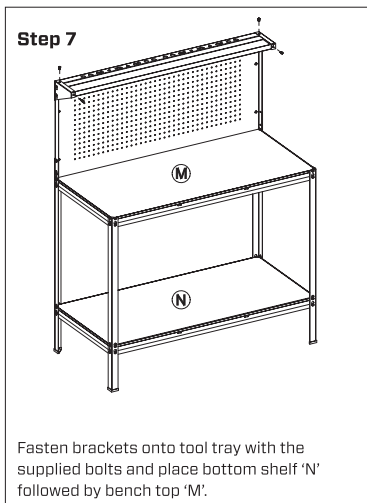
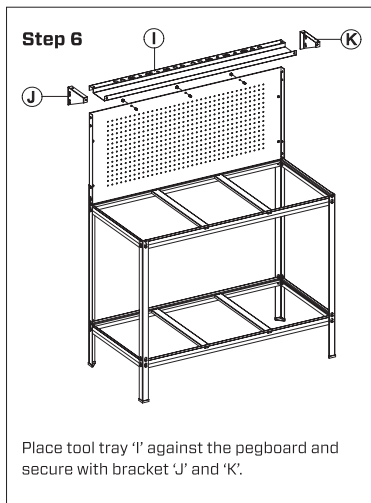
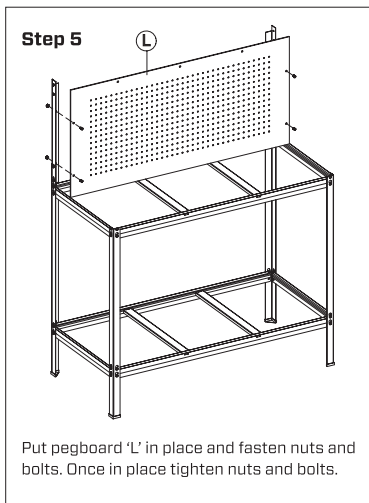
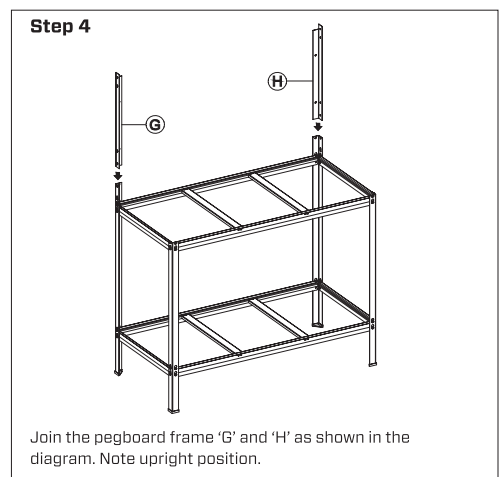
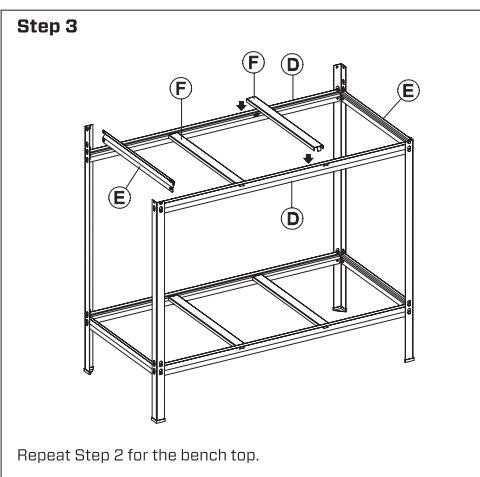
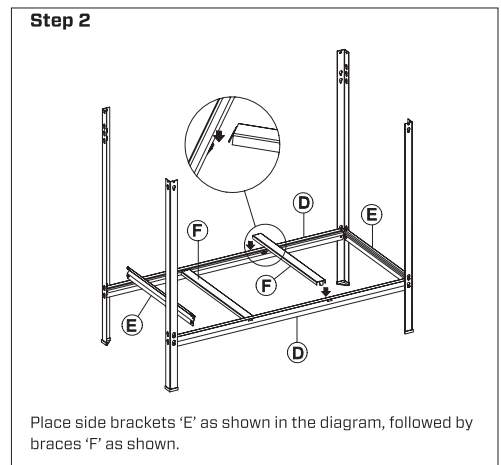
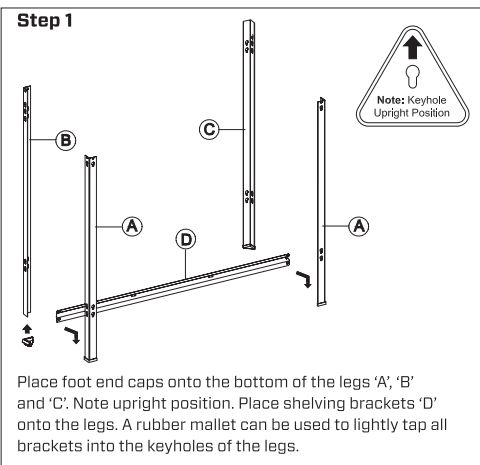

WARRANTY CONDITIONS

Any claim under this warranty must be made within 1 year of the date of purchase of the product. To make a claim under this warranty, take the product (with proof of purchase) to any Bunnings store (see www.bunnings.com.au for store locations). Pinnacle Hardware bears reasonable, direct expenses of claiming under the warranty. You may submit details and proof of purchase to our support centre for consideration. The warranty covers manufacturer defects in materials, workmanship and finish under normal use. This warranty is provided in addition to other rights and remedies you may have under law. Our goods come with guarantees that cannot be excluded under the Australian consumer law or Consumer Guarantees Act 1993 (NZ). You are entitled to a replacement or refund for a major failure and compensation for any other reasonably foreseeable loss or damage. You are also entitled to have the goods repaired or replaced if the goods fail to be of acceptable quality and the failure does not amount to a major failure. This warranty excludes damage resulting from product misuse or product neglect. The warranty covers domestic use only and does not apply to commercial applications. This warranty is given by Pinnacle Hardware, ABN 87 614 496 196, 28 Hudson Court, Keysborough Vic 3173, 1800 349 776, Email: support@pinnacle.net.au. New Zealand customers please contact HARCO (Harkness & Young Ltd), 09 27 64071, Email: sales@harknessyoung.co.nz. 'Pinnacle' is a trademark. © Pinnacle Hardware. Suitable for model number G0S018.