

4 PIECE PEGBOARD & BRACKET SET

900H x 1800Wmm

ITEM NO: GOS025

**POWDER
COATED**

Very Important: Unpack the unit and confirm that you have all the parts listed. Assemble the unit on a solid, level surface. Avoid carpet. You will need the assistance of a second person during assembly. **You will need the following:** Rubber mallet, Phillips-head screwdriver and an adjustable spanner.

SAFETY TIP:

When assembling or installing this product wear protective gloves and eyewear.

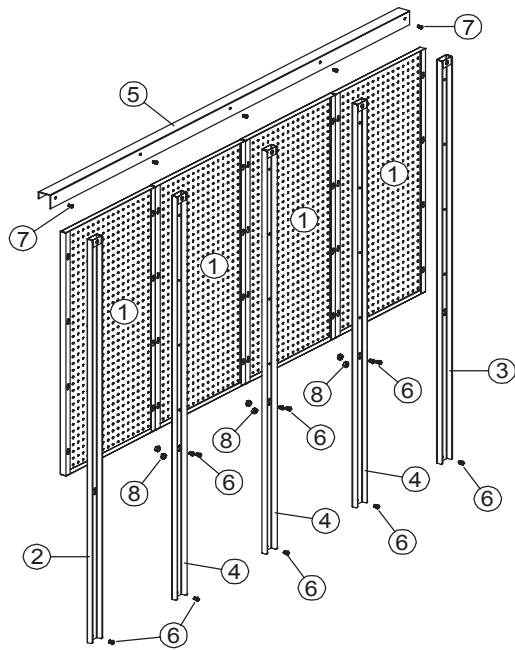

NO.	PARTS LIST	PCS
1	Pegboard (450x900mm)	4 PCS
2	Right support rail	1 PC
3	Left support rail	1 PC
4	Middle support rail	3 PCS
5	Top support rail	1 PC
6	Pan head bolt (M8x15mm)	11 PCS
7	Pan head screw (M6x15mm)	5 PCS
8	Hex nut (M8)	6 PCS

Step 1

Undo the pan head bolts (M8x70mm) from the backside of the workbench as per diagram above.

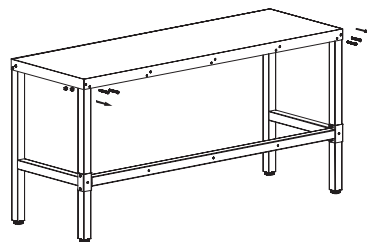

Step 2

Fix the right, left and middle support rails (2, 3 and 4) onto the workbench by reinserting the bolts removed from step 1. Then fix the lower section of the support rails with the provided pan head bolts (6) and hex nuts (8) in the pre-drilled holes as shown in the diagram on the right.

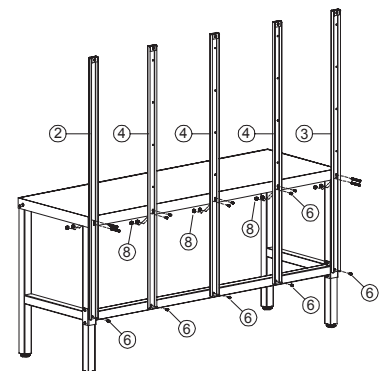

Step 3

Attach the pegboards onto the support rails as shown in the diagram on the right.

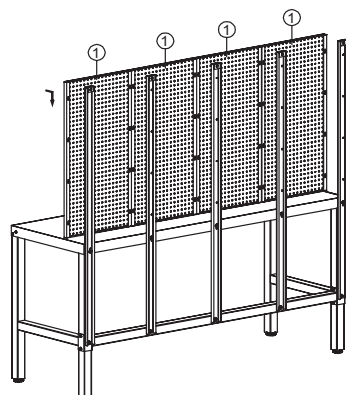

Step 4

Fix the top support rail (5) in place using the provided pan head screws (7) as per diagram to the right.

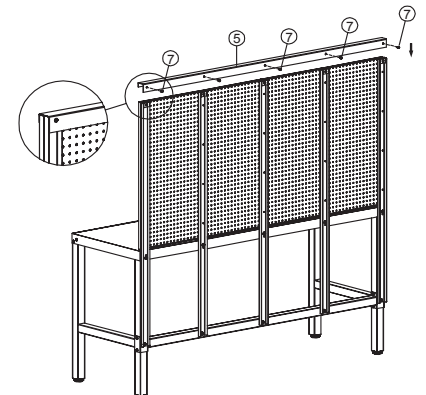

WARRANTY CONDITIONS

Any claim under this warranty must be made within 1 year of the date of purchase of the product. To make a claim under this warranty, take the product (with proof of purchase) to any Bunnings store (see www.bunnings.com.au for store locations). Pinnacle Hardware bears reasonable, direct expenses of claiming under the warranty. You may submit details and proof of purchase to our support centre for consideration. The warranty covers manufacturer defects in materials, workmanship and finish under normal use. This warranty is provided in addition to other rights and remedies you may have under law. Our goods come with guarantees that cannot be excluded under the Australian consumer law. You are entitled to a replacement or refund for a major failure and compensation for any other reasonably foreseeable loss or damage. You are also entitled to have the goods repaired or replaced if the goods fail to be of acceptable quality and the failure does not amount to a major failure. This warranty excludes damage resulting from product misuse or product neglect. The warranty covers domestic use only and does not apply to commercial applications. This warranty is given by Pinnacle Hardware, ABN 67 614 496 196, 28 Hudson Court, Keysborough Vic 3173, 1800 349 776, Email: support@pinnacle.net.au. New Zealand customers please contact HARCO (Harkness & Young Ltd), 09 27 64071, Email: sales@harknessyoung.co.nz. 'Pinnacle' is a trademark. © Pinnacle Hardware. Suitable for model number GOS025.