

ozito

AIRLESS PAINT SPRAYER

650W

INSTRUCTION MANUAL

SPECIFICATIONS

Input Power:	650W
Voltage:	230-240V ~ 50Hz
Max. Pressure:	3000psi (21MPa)
Max. Flow Rate:	1.09±10% l/min
Spray Tip Size:	515
Outlet Paint Connector:	1/4-18NPSM
Max. Hose Pressure:	12000psi (83MPa)
High Pressure Hose:	7.6m
Full-load Current:	2.0-3.1A
Short Circuit Rating:	5kA
Paint Temperature:	5-40°C
Weight:	7.69kg

ozito.com.au

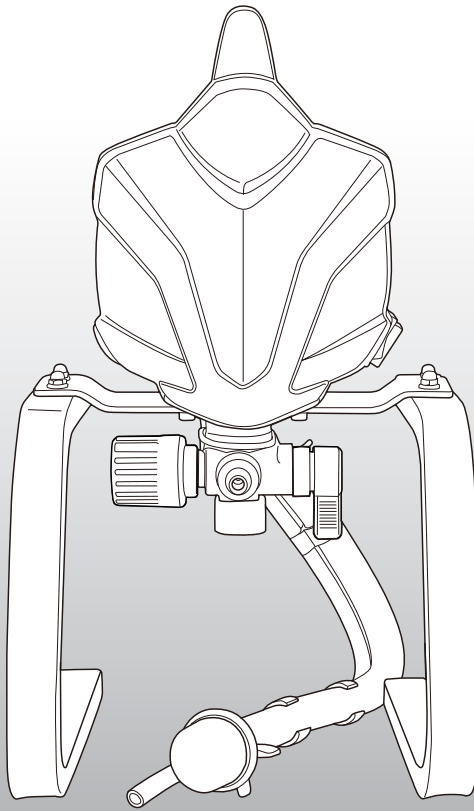

WHAT'S IN THE BOX



Airless Sprayer



Spray Gun



High Pressure Hose

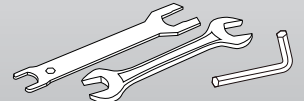

Hex Key and Spanner x 2



Cleaning Brush

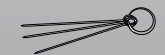

Fine Needle x 3

1 YEAR REPLACEMENT WARRANTY

ASG-6000

WARRANTY

IN ORDER TO MAKE A CLAIM UNDER THIS WARRANTY YOU MUST RETURN THE PRODUCT TO YOUR NEAREST BUNNINGS WAREHOUSE WITH YOUR BUNNINGS REGISTER RECEIPT. PRIOR TO RETURNING YOUR PRODUCT FOR WARRANTY PLEASE TELEPHONE OUR CUSTOMER SERVICE HELPLINE:

Australia 1800 069 486

New Zealand 0508 069 486

TO ENSURE A SPEEDY RESPONSE PLEASE HAVE THE MODEL NUMBER AND DATE OF PURCHASE AVAILABLE. A CUSTOMER SERVICE REPRESENTATIVE WILL TAKE YOUR CALL AND ANSWER ANY QUESTIONS YOU MAY HAVE RELATING TO THE WARRANTY POLICY OR PROCEDURE.

The benefits provided under this warranty are in addition to other rights and remedies which are available to you at law.

Our goods come with guarantees that cannot be excluded at law. You are entitled to a replacement or refund for a major failure and for compensation for any other reasonably foreseeable loss or damage. You are also entitled to have the goods repaired or replaced if the goods fail to be of acceptable quality and the failure does not amount to a major failure.

Generally you will be responsible for all costs associated with a claim under this warranty, however, where you have suffered any additional direct loss as a result of a defective product you may be able to claim such expenses by contacting our customer service helpline above.

1 YEAR REPLACEMENT WARRANTY

Your product is guaranteed for a period of **12 months from the original date of purchase**. If a product is defective it will be replaced in accordance with the terms of this warranty.

Warranty excludes consumable parts, for example: carbon brushes, chuck, depth rod, chuck key, auxiliary handle.

WARNING

The following actions will result in the warranty being void.

- If the tool has been operated on a supply voltage other than that specified on the tool.
- If the tool shows signs of damage or defects caused by or resulting from abuse, accidents or alterations.
- Failure to perform maintenance as set out within the instruction manual.
- If the tool is disassembled or tampered with in any way.

KNOW YOUR PRODUCT

AIRLESS SPRAY GUN

- | | |
|-------------------------|-----------------|
| 1 Pressure Control Dial | 6 Inlet Hose |
| 2 Stand | 7 Priming Lever |
| 3 Return Pipe | 8 On/Off Switch |
| 4 Paint Outlet | 9 Carry Handle |
| 5 Filter | |

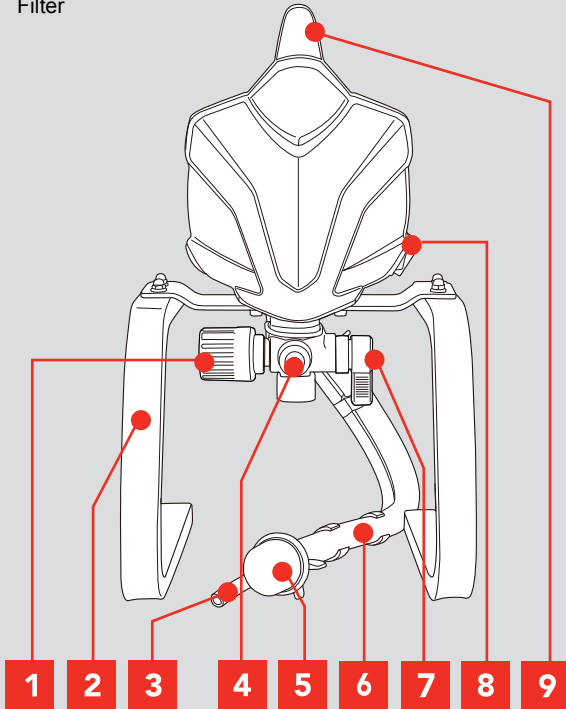

- | | |
|----------------------------|--------------------|
| 10 Nozzle Tip | 14 Spanner x 2 |
| 11 Spray gun | 15 Hex Key |
| 12 7.6m High pressure hose | 16 Fine Needle x 3 |
| 13 Spray Gun Filter | 17 Cleaning Brush |

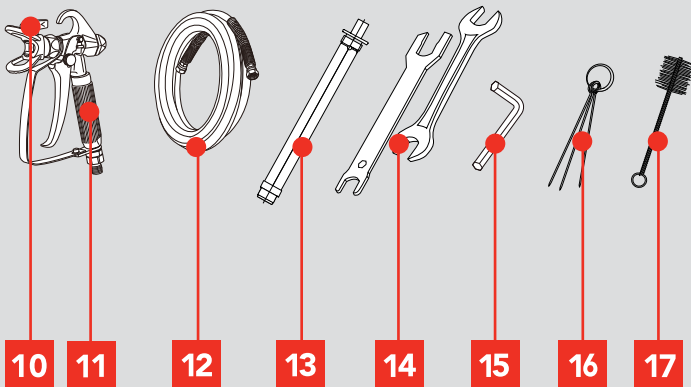

ONLINE MANUAL

Scan this QR Code with your mobile device to take you to the online manual.



SETUP & PREPARATION

1. ASSEMBLY



WARNING! ENSURE THE TOOL IS DISCONNECTED FROM THE POWER SUPPLY BEFORE PERFORMING ANY OF THE FOLLOWING OPERATIONS.

Frame Connection

- 1 Remove four bolts from frame.

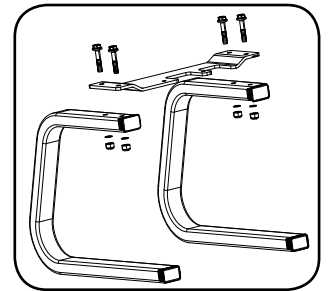

- 2 Reposition pump on frame, so legs face backwards. Reconnect pump to frame with four bolts.

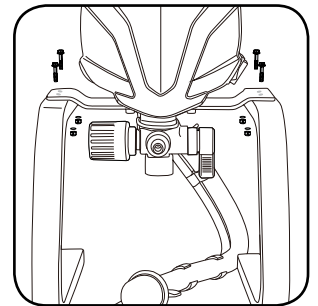

Hose Connection

- 1 Connect high pressure hose to paint outlet and tighten.

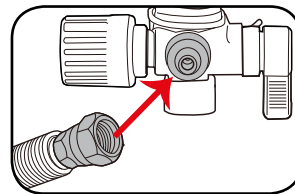

- 2 Connect other end of hose to gun swivel and tighten.

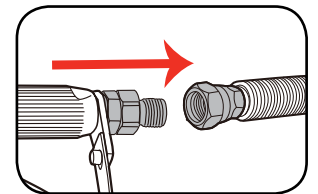

- 3 Ensure all connections have been correctly tightened with a 19mm spanner.

- 4 Connect the inlet hose and return pipe to the back of the unit. Secure the return pipe by releasing the tabs on the hose clamp.

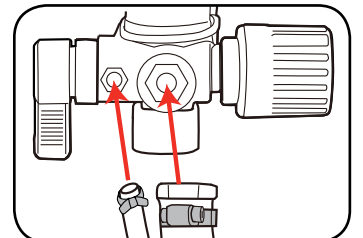

- 5 Secure inlet hose by tightening screw on hose clamp with a flat head screwdriver.

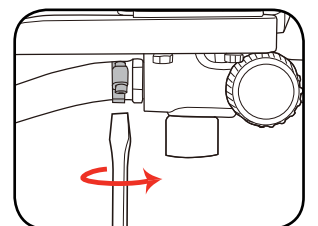

1 YEAR WARRANTY

2. ASSEMBLY CONT.

Spray Tip & Guard

Note: The spray gun comes assembled from the factory. If the spray gun has been disassembled for cleaning, follow the steps below to re-assemble.

- 1 Insert the mesh filter into the handle and align the handle with the upper part of the spray gun.

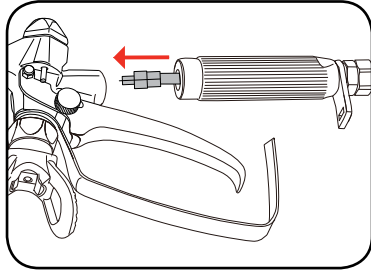

- 2 While holding the upper section of the spray gun, tighten the handle using a 21mm spanner.

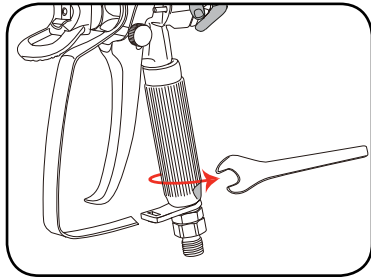

- 3 Slide the trigger guard onto the tab on the handle and tighten using a 3mm hex key and spanner.

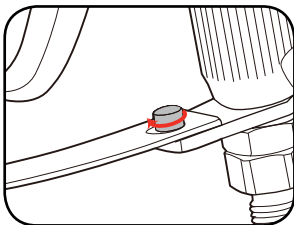

- 4 Ensure the small spacer and washer that locate the nozzle tip are inserted in the nozzle.

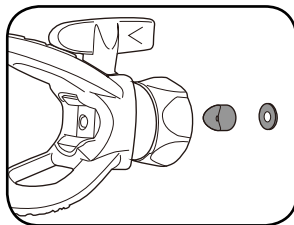

- 5 Place guard over end of gun then insert nozzle tip.

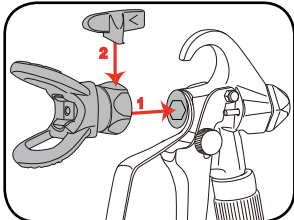

- 6 Tighten retaining nut.

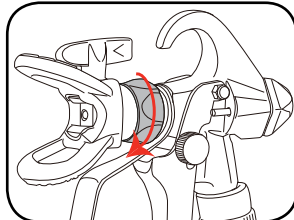

3. PREPARATION



WARNING! THIS TOOL IS RECOMMENDED FOR THE USE WITH RESIDUAL CURRENT DEVICE WITH A RATED RESIDUAL CURRENT OF 30MA OR LESS.

Note: Do not thin paint for use in this spray gun.

Locking the Spray Gun Trigger

The spray gun trigger should be locked prior to preparing the spray station to ensure the trigger does not accidentally get released.

- 1 To lock the spray gun trigger, rotate the trigger locking screw clockwise.

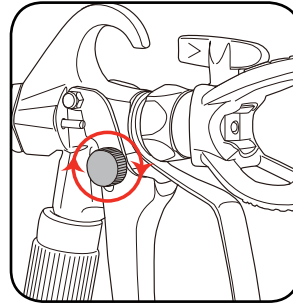

- 2 To unlock the trigger, rotate the trigger locking screw clockwise.

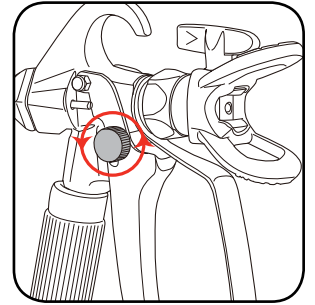

Priming Operation

- 1 Fully submerge filter and return pipe in coating material.

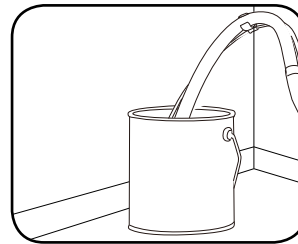

- 2 Set pressure control dial to prime.

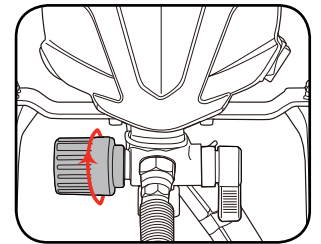

- 3 To set the pressure control dial correctly, align the central mark with the desired setting icon.

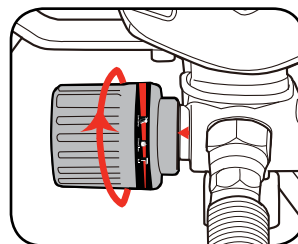

- 4 Set priming lever to prime, then turn unit on.

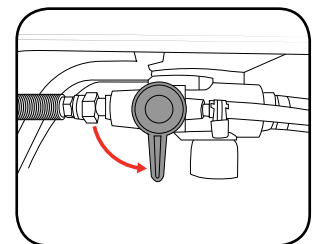

OPERATION

4. PREPARATION CONT.

5 Wait for air bubbles to clear return pipe, this is indicated by a steady stream of paint out of return pipe.

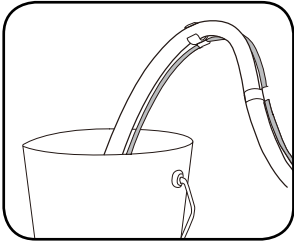

6 Return priming lever to spray position.

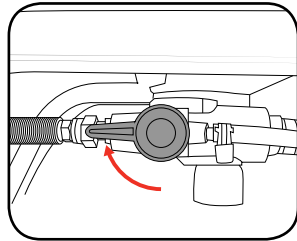

7 Wait for the Airless Sprayer to automatically cut out, after a few moments. The sprayer is now ready to use.

Note: If the Airless Sprayer does not shut off automatically, repeat steps 4 to 7.

5. TEST SETTINGS

Setting Pressure

1 Set the pressure control dial to a medium - high pressure.

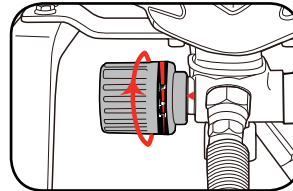

2 Test this pressure setting on a scrap piece of material.

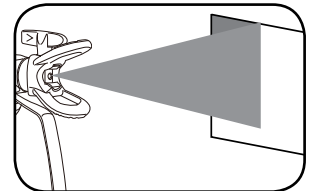

3 Adjust the pressure setting until a smooth even consistency is achieved.

Speed

1 On a scrap piece of material, spray a test patch assessing the speed of stroke required for pressure setting. Lower pressure will require slower speeds and higher pressure faster speeds.

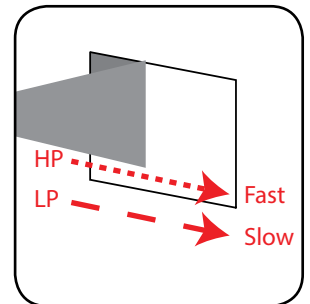

Aligning Spray

1 Refer to section 7 Pressure Release. Then rotate the spray guard to match the direction of preferred spray pattern.

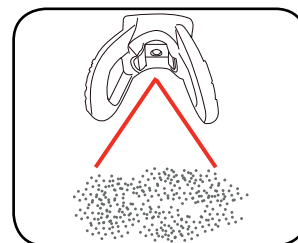
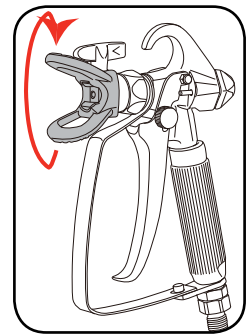

Horizontal

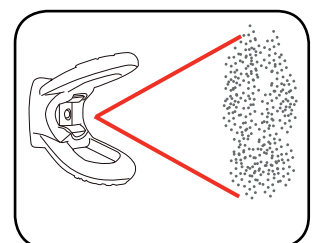

Vertical

Note: The spraying result depends considerably on how well prepared the surface is for painting. Carefully complete proper surface preparation for painting before beginning to spray.

6. SPRAYING PROCEDURE

Note: Ensure the Airless Sprayer has been properly primed before commencing spraying procedure.

- 1 Stand 30cm from area to be sprayed. Maintain this distance.
- 2 Turn the Airless Sprayer on. Release the trigger lock. Ensure the priming lever is in the spray position.

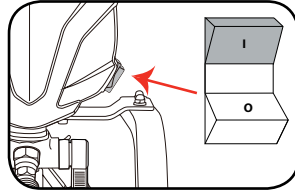
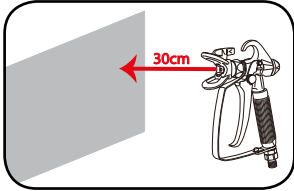

- 3 Begin 15cm off the edge of the area being sprayed. Start the movement of the stroke before squeezing the trigger.

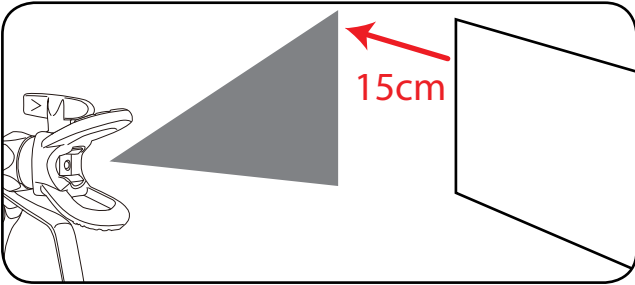

- 4 Release the trigger once past the opposite edge of the area being sprayed.

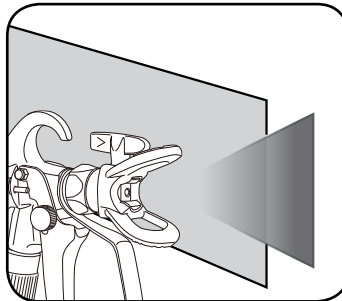

7. SPRAYING TECHNIQUE

- 1 Move the gun with the entire arm, not by flexing the wrist. This will keep the spray gun at right angles to the surface, keeping the pattern even.

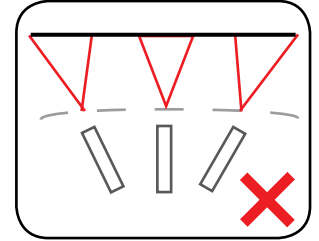
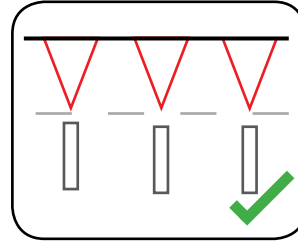

- 2 Keep the spray gun perpendicular to the surface, so spray distance is consistent.

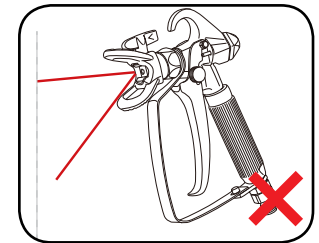
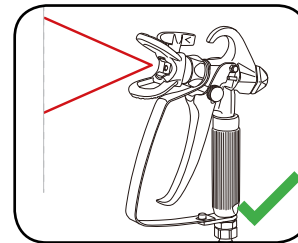

- 3 Overlap each stroke by 30% to ensure even coverage.

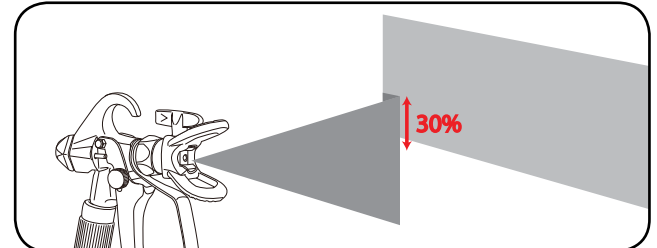

Helpful Hints

- 1 Do not spray outdoors on a windy day as the results may be unsatisfactory.
- 2 Only apply one coat at a time, always allow a coat to completely dry before adding another coat.
- 3 Avoid stopping and starting as this can lead to a patchy finish. It is best to start spraying outside the surface to be sprayed and avoid stopping in the middle of the surface, continue just past the opposite edge.

8. PRESSURE RELEASE

Interim Procedure

If taking a break from spraying for more than several minutes, perform the pressure release procedure below. Place the spray tip in a bucket of water to prevent paint from drying and forming blockages in the spray gun.

Pressure Release Procedure

- 1 Turn trigger safety lock on.
- 2 Adjust the pressure control dial to cleaning setting.

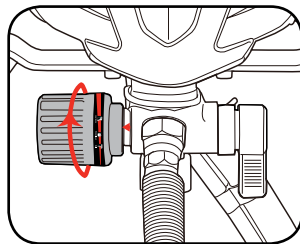
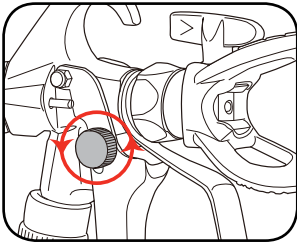

- 3 Turn off pump and then put the priming lever into prime position.

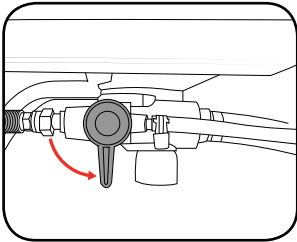

Prime Position

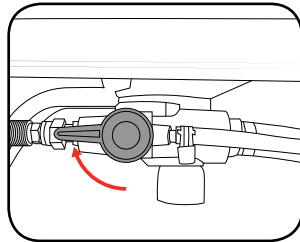

Spray Position

- 4 Unlock the trigger and squeeze to release any remaining pressure in the gun.

Back-up Pressure Release

If the priming lever fails to reduce pressure in the system, press the button located underneath the paint outlet to release the suction pressure.

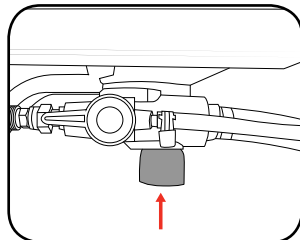

9. SPRAY TIP SELECTION

Spray tips are numbered so that:

- The first digit, when multiplied by two, gives the spray width in inches
- The last two digits specify the orifice size in thousandths of an inch (Note: a larger orifice increases paint flow).

The following are recommended spray tip orifice sizes for varying types of coating material:

Lacquer & Stain: 0.007 - 0.013

Enamel: 0.011 - 0.015

Acrylic: 0.015 - 0.021

This product is provided with a 0.015 tip size.

When selecting a spray tip, choose one that has an orifice size within the above recommended ranges and a spray width to suit the object to be painted. **The below table has been provided to help with spray tip selection.**

Spray Width (Inches)	Orifice Size (Inches)															
	.007	.009	.011	.013	.015	.017	.019	.021	.023	.025	.027	.029	.031	.033	.035	
2-4	107															
4-6		209	211	213	215	217	219	221		225	227	229	231		235	
6-8		309	311	313	315	317	319	321	323	325	327	329	331	333	335	
8-10			411	413	415	417	419	421	423	425	427	429	431	433	435	
10-12			511	513	515	517	519	521	523	525	527	529	531	533	535	
12-14			611	613	615	617	619	621	623	625	627	629	631	633	635	
14-16			711	713	715	717	719	721	723	725	727	729	731	733	735	
16-18				813	815	817	819	821	823	825	827	829	831	833	835	
18-20									923		927		931	933	935	

Note: When changing tip sizes, the spray gun filter size may also need to be changed. Please contact our Customer Service Department.





CLEANING PROCEDURE

Please follow instructions in Cleaning Manual.

Caution: It is crucial to perform the pressure release procedure before starting the cleaning procedure. Follow this procedure diligently as a build-up of dried paint on the operating components can stop the unit from working.

If coating material was acrylic based, use water in the following procedure. If coating material was oil based ie. enamel or lacquer, use solvent based cleaners such as turps.

DESCRIPTION OF SYMBOLS

V	Volts	Hz	Hertz
~	Alternating current	L/min	Liters per minute
psi	Pounds per square inch	MPa	Megapascals
	Double insulated		Regulator compliance mark
	Warning		Read instruction manual
	Wear eye, ear and respiratory protection		

CARING FOR THE ENVIRONMENT



Power tools that are no longer usable should not be disposed of with household waste but in an environmentally friendly way. Please recycle where facilities exist. Check with your local council authority for recycling advice.



Recycling packaging reduces the need for landfill and raw materials. Reuse of recycled material decreases pollution in the environment. Please recycle packaging where facilities exist. Check with your local council authority for recycling advice.

MAINTENANCE

Follow the cleaning procedure after each use. Ensure the unit is thoroughly cleaned before storing to prevent build up of dried paint which can cause blockages and stop the unit from working.

Coil the high pressure hose after cleaning and for storage to prevent damage to the hose.

Caution: Be sure to follow the pressure release procedure when shutting the airless sprayer down for any purpose, including cleaning or adjusting.

TROUBLESHOOTING

Problem	Cause	Remedy
Little or no material flow	Nozzle clogged	Clean using needle
	Suction tube clogged	Clean
	Pressure control dial turned too low (-)	Increase pressure control dial setting (+)
	Suction tube loose	Insert and tighten hose clamp
Material leaking	Inlet filter clogged	Clean or replace
	Nozzle loose	Tighten
	Nozzle worn	Replace
	Nozzle seal worn	Replace
	Material build-up on air cap and nozzle	Clean
Atomization is too coarse	Larger tip and filter required	Refer to spray tip selection chart
	Material volume too large	Decrease pressure control dial setting (-)
	Nozzle clogged	Clean
	Inlet filter clogged	Clean or replace
Pattern runs or sags	Applying too much material	Adjust pressure control dial or increase movement of spray gun
Too much over-spray	Gun too far from spray object	Reduce distance
	Too much material applied	Decrease pressure control dial setting (-)
Pattern is very light and splotchy	Moving the spray gun too fast	Adjust pressure control dial or decrease movement of spray gun
Spluttering paint	Air bubbles in the return pipe	Complete bleeding operation to remove air bubbles
Inlet hose not sucking up water when cleaning the unit	Lack of pressure	Complete the bleeding operation to re-prime the unit

SPARE PARTS

Spray Gun	SPASG6000-127
Filter (hose)	SPASG6000-031
High Pressure Hose	SPASG6000-128
Filter (nozzle)	SPASG6000-12709
Output Lever	SPASG6000-12738
Spray Guard Assembly	SPASG6000-12741A
Tip Guard Seal	SPASG6000-12737A
Bleeder Valve Assembly	SPASG6000-010A
Pressure Relief Valve Assembly	SPASG6000-019A
Pump Column Assembly	SPASG6000-060A

Spare parts can be ordered from the Special Orders Desk at your local Bunnings Warehouse.

For further information, or any parts not listed here, visit www.ozito.com.au or contact Ozito Customer Service:

Australia 1800 069 486

New Zealand 0508 069 486

E-mail: enquires@ozito.com.au

ELECTRICAL SAFETY



WARNING! When using mains-powered tools, basic safety precautions, including the following, should always be followed to reduce risk of fire, electric shock, personal injury and material damage.

Read the whole manual carefully and make sure you know how to switch the tool off in an emergency, before operating the tool.

Save these instructions and other documents supplied with this tool for future reference.

The electric motor has been designed for 230V and 240V only. Always check that the power supply corresponds to the voltage on the rating plate.

Note: The supply of 230V and 240V on Ozito tools are interchangeable for Australia and New Zealand.

If the supply cord is damaged, it must be replaced by an electrician or a power tool repairer in order to avoid a hazard.

If operating a power tool in a damp location is unavoidable, use a residual current device (RCD) protected supply. Use a RCD reduces the risk of electric shock.

Using an Extension Lead

Always use an approved extension lead suitable for the power input of this tool. Before use, inspect the extension lead for signs of damage, wear and ageing. Replace the extension lead if damaged or defective.

When using an extension lead on a reel, always unwind the lead completely. Use of an extension lead not suitable for the power input of the tool or which is damaged or defective may result in a risk of fire and electric shock.

GENERAL POWER TOOL SAFETY WARNINGS



WARNING! Read all safety warnings and all instructions. Failure to follow the warnings and instructions may result in electric shock, fire and/or serious injury.

Save all warnings and instructions for future reference. The term "power tool" in the warnings refers to your mains-operated (corded) power tool or battery-operated (cordless) power tool.

1. Work area safety

- Keep work area clean and well lit. Cluttered or dark areas invite accidents.
- Do not operate power tools in explosive atmospheres, such as in the presence of flammable liquids, gases or dust. Power tools create sparks which may ignite the dust or fumes.
- Keep children and bystanders away while operating a power tool. Distractions can cause you to lose control.

2. Electrical safety

- Power tool plugs must match the outlet. Never modify the plug in any way. Do not use any adapter plugs with earthed (grounded) power tools. Unmodified plugs and matching outlets will reduce risk of electric shock.
- Avoid body contact with earthed or grounded surfaces, such as pipes, radiators, ranges and refrigerators. There is an increased risk of electric shock if your body is earthed or grounded.
- Do not expose power tools to rain or wet conditions. Water entering a power tool will increase the risk of electric shock.
- Do not abuse the cord. Never use the cord for carrying, pulling or unplugging the power tool. Keep cord away from heat, oil, sharp edges or moving parts. Damaged or entangled cords increase the risk of electric shock.
- When operating a power tool outdoors, use an extension cord suitable for outdoor use. Use of a cord suitable for outdoor use reduces the risk of electric shock.
- If operating a power tool in a damp location is unavoidable, use a residual current device (RCD) protected supply. Use of an RCD reduces the risk of electric shock.

3. Personal safety

- Stay alert, watch what you are doing and use common sense when operating a power tool. Do not use a power tool while you are tired or under the influence of drugs, alcohol or medication. A moment of inattention while operating power tools may result in serious personal injury.
- Use personal protective equipment. Always wear eye protection. Protective equipment such as dust mask, non-skid safety shoes, hard hat, or hearing protection used for appropriate conditions will reduce personal injuries.
- Prevent unintentional starting. Ensure the switch is in the off-position before connecting to power

source and/or battery pack, picking up or carrying the tool. Carrying power tools with your finger on the switch or energising power tools that have the switch on invites accidents.

- Remove any adjusting key or wrench before turning the power tool on.

A wrench or a key left attached to a rotating part of the power tool may result in personal injury.

- Do not overreach. Keep proper footing and balance at all times. This enables better control of the power tool in unexpected situations.

- Dress properly. Do not wear loose clothing or jewellery. Keep your hair, clothing and gloves away from moving parts. Loose clothes, jewellery or long hair can be caught in moving parts.

- If devices are provided for the connection of dust extraction and collection facilities, ensure these are connected and properly used. Use of dust collection can reduce dust-related hazards.

4. Power tool use and care

- Do not force the power tool. Use the correct power tool for your application. The correct power tool will do the job better and safer at the rate for which it was designed.
- Do not use the power tool if the switch does not turn it on and off. Any power tool that cannot be controlled with the switch is dangerous and must be repaired.
- Disconnect the plug from the power source and/or the battery pack from the power tool before making any adjustments, changing accessories, or storing power tools. Such preventive safety measures reduce the risk of starting the power tool accidentally.
- Store idle power tools out of the reach of children and do not allow persons unfamiliar with the power tool or these instructions to operate the power tool. Power tools are dangerous in the hands of untrained users.
- Maintain power tools. Check for misalignment or binding of moving parts, breakage of parts and any other condition that may affect the power tool's operation. If damaged, have the power tool repaired before use. Many accidents are caused by poorly maintained power tools.
- Keep cutting tools sharp and clean. Properly maintained cutting tools with sharp cutting edges are less likely to bind and are easier to control.
- Use the power tool, accessories and tool bits etc. in accordance with these instructions, taking into account the working conditions and the work to be performed. Use of the power tool for operations different from those intended could result in a hazardous situation.

5. Service

- Have your power tool serviced by a qualified repair person using only identical replacement parts. This will ensure that the safety of the power tool is maintained.

AIRLESS SPRAY GUN SAFETY WARNINGS



WARNING!

Hold power tool by insulated gripping surfaces, when performing an operation where the cutting accessory may contact hidden wiring or its own cord. Cutting accessory contacting a "live" wire may make exposed metal parts of the power tool "live" and could give the operator an electric shock.

This appliance is not intended for use by persons (including children) with reduced physical, sensory or mental capabilities, or lack of experience and knowledge, unless they have been given supervision or instruction concerning use of the appliance by a person responsible for their safety.

Recommendations for the use of a residual current device with a rated residual current of 30mA or less.



WARNING!

NEVER under any circumstances aim the nozzle at another person or animal.

- In the event of an injury occurring, seek medical advice immediately.
- The spray gun must not be used for spraying flammable paints and solvents with a flash point of less than 21°C.
- Always ensure there is adequate ventilation when spraying.
- The use of ear protection is recommended.
- Eye protection is recommended to keep hazardous vapours and liquids out of eyes.
- Always wear a face mask when spraying.
- Always read the paint manufacturers thinning instructions before using.
- Always keep the spray basket nozzle in place during use. Never allow the spray to come in direct contact with the skin.



WARNING!

DANGER! Never immerse the spray gun in liquid. This could lead to electric shock, personal injury and material damage.

- The spray gun must not be cleaned by using flammable liquids with a flash point of less than 21°C.

NEVER spray near a naked flame, including an appliance pilot light.

NEVER smoke whilst spraying.

NEVER allow children to operate or play with the spray gun.

- Before cleaning, always disconnect the appliance from the mains supply.
- Always disconnect from mains supply when refilling the paint pot.
- After every use ensure you clean your spray gun thoroughly.

NEVER use the spray gun outside when it is raining.



WARNING!

The ASG-6000 Airless Spray Gun operates at very high pressure. For safe operation the following must be observed at all times.

- Do not point the spray gun at yourself or any other person. Injury from penetration to the skin and paint solvents being injected into the body can result.
- Always check for leaks and correct operation before use. Never operate the spray gun if there are any leaks or faults. Faults or leaks can cause injury.
- Release the pressure when not in use. Pressure can remain in the unit and hose when switched off.

Injury where paint or solvent injection into the skin or body occurs can be very serious. Always seek professional medical help and advise the paints or solvents used.

NEVER use the spray gun without the trigger safety guard fitted.

ozito

AIRLESS PAINT SPRAYER

650W

Cleaning Manual

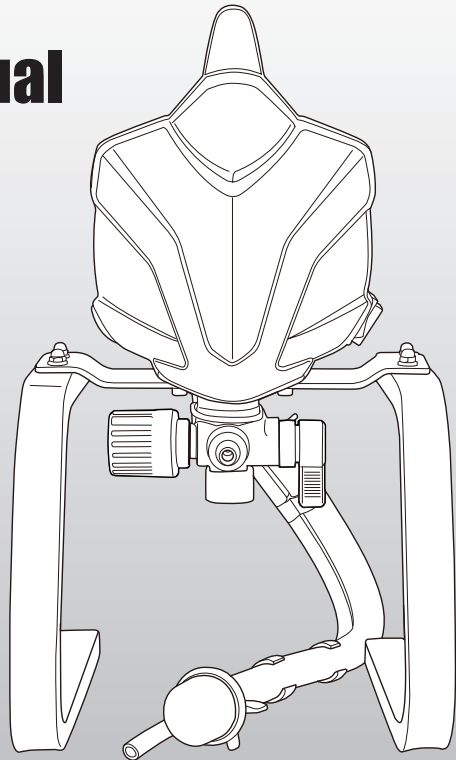

This cleaning process must be followed immediately after use to prevent paint from drying inside the pump and hose. Failure to follow this instruction may permanently seize the paint sprayer.

CONTENTS

Know Your Product.....	Page 2
Pressure Release Procedure.....	Page 3
Acrylic Vs Oil Based.....	Page 4
Cleaning the Unit	Page 4
Cleaning the Inlet Hose.....	Page 6
Cleaning the Spray Gun.....	Page 6
Storage.....	Page 8
Spare Parts.....	Page 8

KNOW YOUR PRODUCT

AIRLESS SPRAY GUN

- | | | |
|-------------------------|-----------------|-----------------------|
| 1 Pressure Control Dial | 4 Paint Outlet | 10 Nozzle Tip |
| 2 Stand | 5 Filter | 11 Spray Gun |
| 3 Inlet Return Pipe | 6 Inlet Hose | 12 High Pressure Hose |
| | 7 Priming Lever | 13 Spray Gun Filter |
| | 8 On/Off Switch | 14 Spanner x 2 |
| | 9 Carry Handle | 15 Hex Key |
| | | 16 Fine Needle x 3 |
| | | 17 Cleaning Brush |

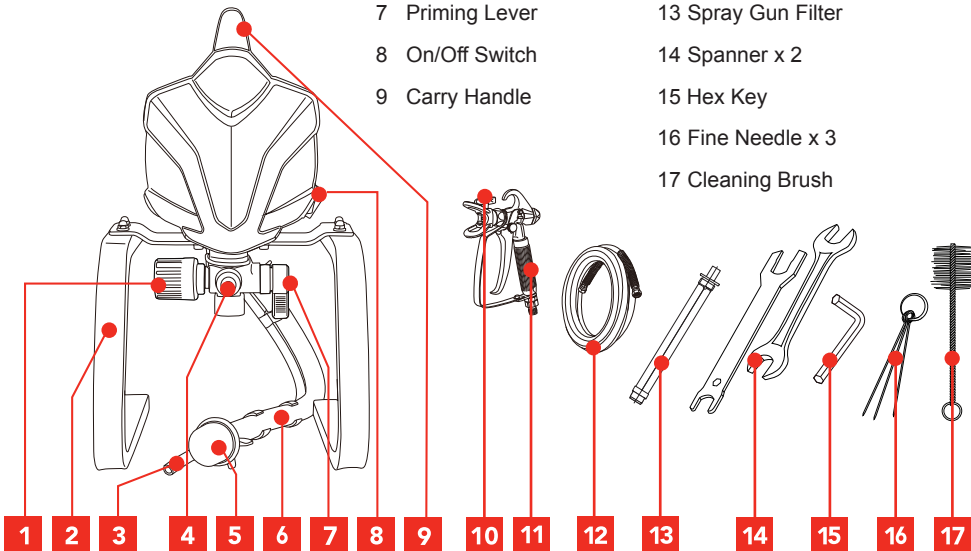

PRESSURE RELEASE PROCEDURE



WARNING! BEFORE BEGINNING THE CLEANING PROCESS, ENSURE THE PRESSURE RELEASE PROCEDURE BELOW IS PERFORMED.

Follow this procedure diligently as a build-up of dried paint on the operating components can stop the unit from working.

1 Turn trigger safety lock on.

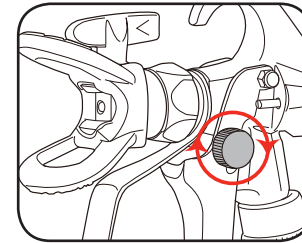

2 Adjust the pressure control dial to cleaning setting.

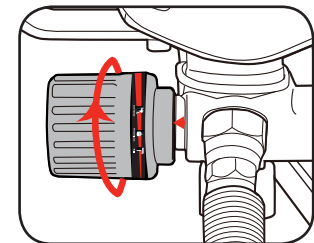

3 Turn off pump and then put priming lever into prime position.

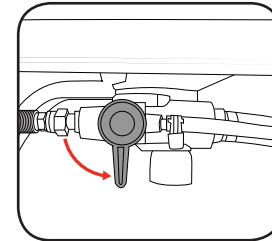

Prime Position

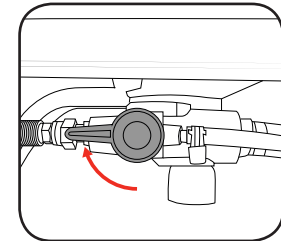

Spray Position

4 Unlock the trigger and squeeze trigger to release any remaining pressure in gun.

Back-up Pressure Release

If the priming lever fails to reduce pressure in the system, press the button located underneath the paint outlet to release the suction pressure.

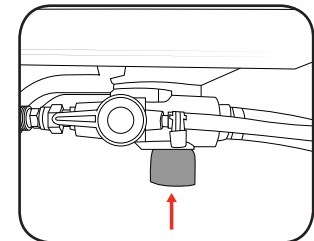

ACRYLIC VS OIL BASED

If coating material was water based (acrylic paint), use ONLY water when performing the cleaning procedure. Use of solvent based cleaning materials on water based paints will result in a new substance that will be extremely difficult to clean.

If coating material was oil based (enamel paint, lacquer etc.) use ONLY the appropriate cleaning solution. Read the cleaning instructions printed on the coating material's label to determine which cleaning material you need. The following solvent based cleaning products are safe to use in the airless paint sprayer:

- Mineral Turpentine
- Paint Thinner

THE UNIT

Note: Before beginning cleaning procedure ensure the pressure control dial is set to clean/prime setting and the priming lever is in the spray position.

- 1 Place the inlet hose into a bucket of appropriate cleaning solution. Place the return hose into an empty bucket or container.

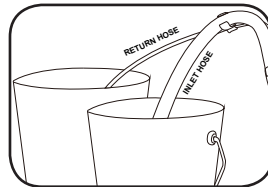

- 2 Turn the unit on, ensuring the priming lever is set to prime. Check the return hose and wait for a constant stream of cleaning solution to pass out of it. Then set the priming lever to the spray position.

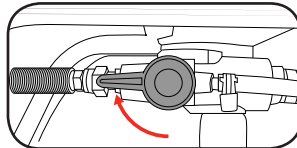

- 3 Aim the spray gun into an empty bucket or container. Squeeze and hold the spray gun trigger until most of the paint is removed from the high pressure hose.

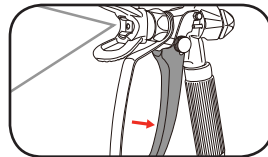

- 4 Lock the spray gun trigger. Rotate the spray tip 180° to the cleaning side. Unlock the spray gun trigger. Squeeze and hold the spray gun trigger to spray the cleaning solution through the system.



- 5 Continue this process until only cleaning solution is ejected from the spray tip. Add more cleaning solution if all of the paint has not been removed.

Note: If the cleaning solution bucket becomes cloudy with paint during cleaning, skip to section: **Cleaning of the inlet hose**. Once the inlet filter and hose are clean, re-assemble them and repeat steps 3-6.

- 6 Move the priming lever to the priming position. Then switch the unit off and disconnect it from the power supply.

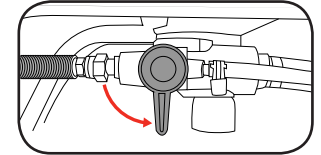

Note: This cleaning process must be followed immediately after use to prevent paint from drying inside the pump and hose. Failure to follow this instruction may permanently seize the paint sprayer.

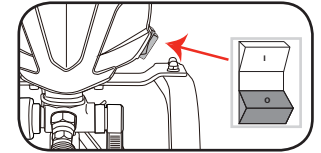

For Water Based Cleaning

We recommend the use of 10-15 litres when performing the cleaning procedure.

For Oil Based Cleaning

We recommend 1-2 litres of the appropriate solvent based cleaner when performing the cleaning procedure.

Note: If you have not finished painting with your airless sprayer and want to take a short break (30-60 minutes), do not leave paint sitting inside the pump. Perform steps 3-5 above to prevent paint from drying inside the pump & hose.

Once you're ready to begin work again simply follow the spraying instructions in the user manual. Once properly primed again, aim the spray gun into a waste bucket and allow 30 seconds for any leftover cleaning solution to be flushed out of the system. Then resume painting as normal.

Note: Mineral Turpentine SHOULD NOT be mixed with water at any stage during the cleaning process.

THE INLET HOSE

- 1 Squeeze the tabs on the inlet hose clamp together and slide the hose clamp away from the filter.
- 2 Pull the filter out and rinse under appropriate cleaning solution.

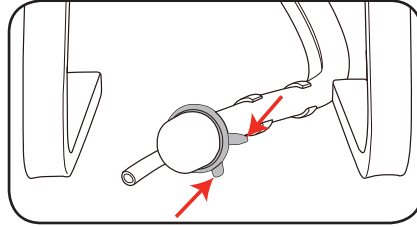
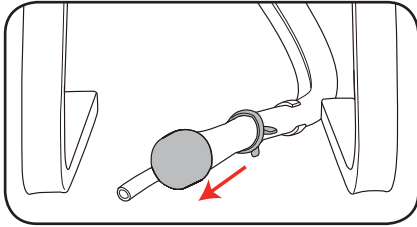

Note: If filter cannot be cleaned it must be replaced.

THE SPRAY GUN

WARNING! ENSURE THE UNIT IS OFF AND THE PRESSURE RELEASE PROCEDURE HAS BEEN PERFORMED.

- 1 Remove the spray gun from the high pressure hose by loosening the nut with a 19mm spanner.
- 2 Remove the nozzle guard and spray tip by loosening the retaining nut. Once the guard assembly has been removed, pull the nozzle tip out.

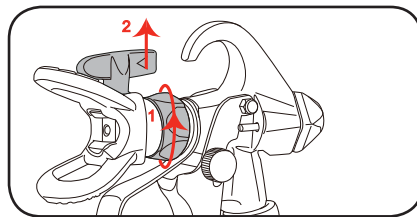
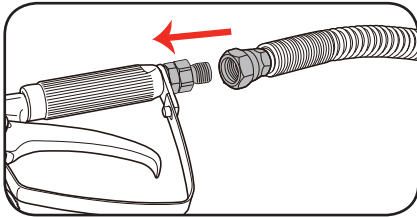

Note: A small spacer and washer are used to locate the nozzle tip within the guard. Be careful not to lose these components when the nozzle guard is removed.



- 3 Using a 3mm hex key and spanner, remove the trigger guard by loosening and removing the nut and bolt used to locate it. Slide the tab out of its groove to free the trigger guard.

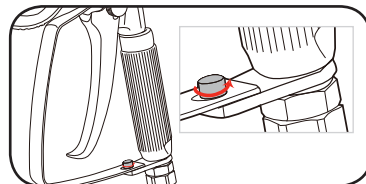

- 4 While holding the upper part of the spray gun, loosen the handle by applying a 21mm spanner to the grooves located on the bottom part of the handle. Rotate anticlockwise until the handle can be completely removed.

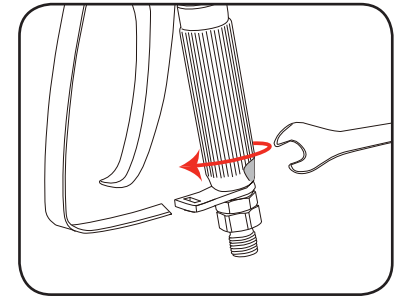

Tip: Using a shifter or bench vice to hold the upper part of the spray gun will make this step much easier.

- 5 Remove the mesh filter from the handle and clean all components in the cleaning solution.

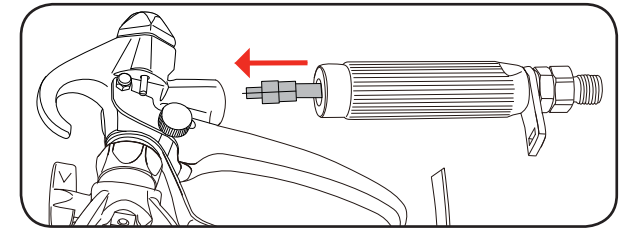

Note: If nozzle tip is blocked, use provided needles by inserting into the nozzle tip.

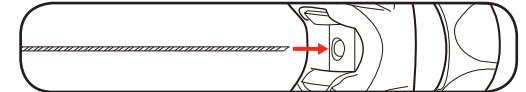

- 6 To clean the mesh filter, unscrew either cap end by turning anti-clockwise. Once unscrewed, remove the cap and pull the other cap and spring out of the mesh filter sleeve. Use the provided brush to scrub the inside of the mesh filter.

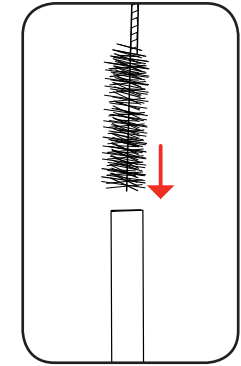
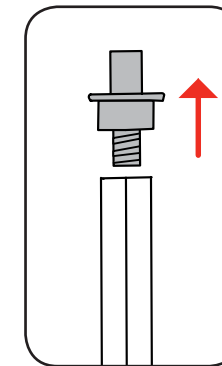
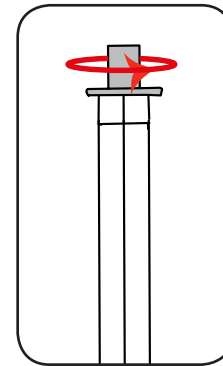

Note: After cleaning, inspect the condition of the filter. If the mesh is clogged with dried paint, has started fraying or has deformed out of shape it will need to be replaced.

- 7 Follow this procedure in reverse to re-assemble the spray gun.

STORAGE

Once you have completed the cleaning procedure, it is important to protect the internal components of the pump before it is stored away. Failure to do so may result in premature wear and corrosion of the pump and various other components in your Airless Paint Sprayer. We recommend Wagner All Guard Pump Protector, available from Bunnings Warehouse. Refer to the manufacturer's instructions for use and follow accordingly.

SPARE PARTS

Should an issue arise with your Airless Paint Sprayer or if you wish to make a claim under the 1 year Replacement Warranty, please call our Customer Service Helpline prior to returning your product.

Spray Gun	SPASG6000-127
Filter (inlet hose)	SPASG6000-031
High Pressure Hose	SPASG6000-128
Filter (spray gun)	SPASG6000-12709
Spray Guard Assembly	SPASG6000-12741A
Spray Tip	SPASG6000-12738
Tip Guard Seal	SPASG6000-12737A
Bleeder Valve Assembly	SPASG6000-010A
Pressure Relief Valve Assembly	SPASG6000-019A
Pump Column Assembly	SPASG6000-060A
Pressure Regulating Valve Assembly	SPASG6000-071A

Note: There are a range of filters available to suit specific types of coating materials. To order a filter to suit your coating material please contact Ozito Customer Service.

Spare parts can be ordered from the Special Orders Desk at your local Bunnings Warehouse.

For further information, or any parts not listed here, visit www.ozito.com.au or contact Ozito Customer Service:

Australia 1800 069 486

New Zealand 0508 069 486

E-mail: enquiries@ozito.com.au