



User Guide

Tastic[®] Neo[™]

Heat • Vent • Light

Model: 31211 Neo Single White - Remote

Model: 31212 Neo Single Silver - Remote

Model: 31111 Neo Single White - Hardwired

Model: 31112 Neo Single Silver - Hardwired

Model: 32111 Neo Dual White - Hardwired

Model: 32112 Neo Dual Silver - Hardwired

Electrical Rating: 230~240 V. 50 Hz.



Model: 31211, 31212, 31111
and 31112 Neo Single



Model: 32111 and 32112 Neo Dual

Welcome

Thank you for buying this IXL Tastic Neo. Even if you have used a Tastic before, there are very good reasons to read this user guide before using this one:

- You and your family, property and home will be safe from harm.
- You will learn how this appliance may differ from others.
- By using the Tastic Neo fully and properly, you will get maximum life and value from it.
- Our warranty depends on you using the Tastic Neo according to this user guide.

It will only take you a few minutes, so please read on!

Contents

Tastic Neo Range	Pg 3-4
Safety	Pg 5-6
How it Works	Pg 6
Ventilation Requirements	Pg 7
Clearances	Pg 7
Overview	Pg 8
Electrical Requirements	Pg 9
Wiring Diagrams	Pg 9-12
Installation	Pg 12-16
Smart Switch Operation	Pg 17
Heat Lamp Replacement	Pg 18-19
CFL Replacement	Pg 20
Replacement Lamps	Pg 21
Cleaning & Maintenance	Pg 21
Frequently Asked Questions (FAQ)	Pg 22-23
Products	Pg 24
Record Your Model	Pg 25
Warranties	Pg 26-27



Model: 31211 Neo Single – White

31211 Neo Single – White

1 x 800 W Tungsten Halogen Heat Lamps
3 x 9 W CFL Downlights
Remote Control
Cutout Template Supplied
170 mm Ducted Blower, 346 m³/hr or 96 l/s

31212 Neo Single – Silver

1 x 800 W Tungsten Halogen Heat Lamps
3 x 9 W CFL Downlights
Remote Control
Cutout Template Supplied
170 mm Ducted Blower, 346 m³/hr or 96 l/s

31111 Neo Single – White

1 x 800 W Tungsten Halogen Heat Lamps
3 x 9 W CFL Downlights
Hardwired
Cutout Template Supplied
170 mm Ducted Blower, 346 m³/hr or 96 l/s



Model: 31112 Neo Single – Silver

31112 Neo Single – Silver

1 x 800 W Tungsten Halogen Heat Lamps
3 x 9 W CFL Downlights
Hardwired
Cutout Template Supplied
170 mm Ducted Blower, 346 m³/hr or 96 l/s



Model: 32111 Neo Dual - White



Model: 32112 Neo Dual - Silver

32111 Neo Dual – White

2 x 800 W Tungsten Halogen Heat Lamps

3 x 9 W CFL Downlights

Hardwired

Cutout Template Supplied

170 mm Ducted Blower, 346 m³/hr or 96 l/s

32112 Neo Dual – Silver

2 x 800 W Tungsten Halogen Heat Lamps

3 x 9 W CFL Downlights

Hardwired

Cutout Template Supplied

170 mm Ducted Blower, 346 m³/hr or 96 l/s



Do not allow insulation material to rest against the sides or top of the Tastic Neo unit when installed. This Tastic unit must be installed horizontally in the ceiling. There is no IP rating on any IXL Tastic Neo.

NOTE: This product must be installed by a qualified installer.

Read through these instructions completely before commencing installation.

The tungsten halogen lamps heat by direct radiation rather than by heating the air in the room, so the Tastic should be located directly over where drying off occurs.

Locate the Tastic in accordance with the requirements of the current Australian/New Zealand Wiring Rules AS/NZS 3000 relating to damp situations.

In some installations this may mean that no part of the Tastic may be located directly above any part of a bath or shower recess or enclosure.

For unenclosed showers refer to Wiring Rules conditions.

Switches and other controls must not be located where they can be touched by a person in the bath or shower.

NOTE: Tastic products must only be installed horizontally in ceiling.

- Do not look directly into heat lamps when in use.
- Tastic products are not tanning lamps.
- Make sure the lamps have cooled and power is off to the Tastic before removing lamps for replacement.
- Do not operate this appliance without the fascia or glass panels in position.
- This appliance is not intended for use by persons (including children) with reduced physical, sensory or mental capabilities, or lack of experience and knowledge, unless they have been given supervision or instruction concerning use of the appliance by a person responsible for their safety.
- Young children should be supervised to ensure they do not play with the appliance.
- This appliance must be mounted with the lowest point at least 2.3 metres from the floor.
- If the supply cord is damaged, it should be replaced by the IXL Appliances or its service agent or a similarly qualified person in order to avoid a hazard.
- This appliance must not be mounted immediately below a socket outlet.

WARNING: Curtains or combustible material may ignite if in contact with the heater.

SAFETY FEATURES

Thermal switch:

When Tastic Neo works in FAN OFF mode and the temperature inside the unit reaches 55°C, the thermal switch will switch on the fan automatically. When the temperature drops, the thermal switch will switch off the fan.

Over-temperature switch (PTCR) (Hardwired Tastic Neo):

When for any reason the temperature inside the unit reaches 80°C, the PTCR will cut off power to the Tastic Neo. The PTCR can be reset by turning off power to the unit at the isolating switch and allowing to cool for 10-15 minutes. In such a case the Service Centre should be called as this is not normal operation.

Thermal fuse: (Remote Tastic Neo only)

When for any reason the temperature inside the unit reaches 93°C, the thermal fuse will cut off power to the Tastic Neo. In such a case the Service Centre should be called to replace the thermal fuse.

How it Works

The IXL Tastic Neo range has been designed to exacting standards to give you many years of trouble-free operation. To ensure you get the most from your Tastic there are a few simple points to keep in mind.

HEAT LAMPS

The IXL Tastic Neo uses 800W tungsten halogen heat lamps in conjunction with reflective elements, for a more efficient dispersion of radiant heat. The tungsten halogen lamps provide instantaneous heat, and are designed to heat you and not your bathroom - that's the efficient way infra red heat works. To get the full benefit of Tastic's tungsten halogen warmth, stand directly under the heat lamps. IXL's exclusive halogen lamps have been designed specifically for this application, and concentrate their heat for maximum effectiveness.

Make sure you have the Tastic model that suits your bathroom ceiling height. This Tastic is manufactured to offer peak performance with bathroom ceiling heights up to 2.4 m.

VENTILATION

To ensure optimum performance of the exhaust fan, it is essential that there is adequate air flow into your bathroom to help the Tastic's efficient exhaust fan to remove steam while you shower, venting directly outside. Your Tastic works by drawing steam-laden air from the room, and as with all exhaust fans it is essential that sufficient air inlets are provided. Ensure adequate inlets exist through windows, vents or under the door. Air flow path from inlet to fan should ideally pass over the steam source.

CENTRE LIGHTS

The 3 compact fluorescent centre lights in Tastic Neo models are designed to provide directional lighting in your bathroom. For specific tasks like shaving or putting make-up on, you may need extra lighting to suit your individual needs.

The heat lamps can also be used to provide additional bright illumination for your bathroom. Lighter coloured walls and decor also help brighten your bathroom by reflecting more light.

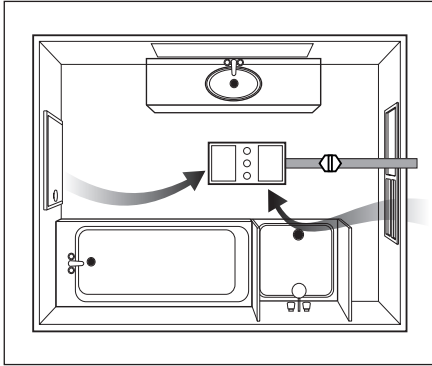

Fig. 1: Ideal placement of Tastic. Sufficient air inlets into room are required

For maximum efficiency and fan performance there are a few key points to keep in mind when installing your Tastic.

Sufficient air inlet into room

Steam will only be removed if there is sufficient flow of air through the room. Ensure generous inlets exist through windows, vents or under the door. Air flow path from inlet to fan should ideally pass over the steam sources (see Fig. 1).

Bathrooms which have high ceilings, are larger than average, or have an open shower may all require additional ventilation. We recommend that you visit our website for further details and suggestions on effectively ventilating your bathroom.

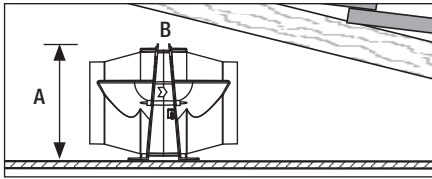

Fig. 2a: Minimum blower clearances

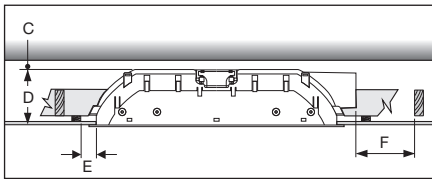

Fig. 2b: Minimum clearances for installation

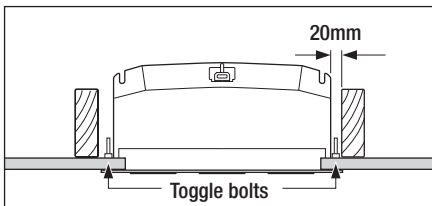

Fig. 2c: Minimum clearances for installation

Clearances

This appliance must be mounted so that the lowest point is at least 2.3 m above the floor. The Tastic body and ducted blower is designed to fit a ceiling cavity or between – floor space with a minimum height of 230 mm. The Tastic may be installed between joists using the supplied toggle bolts (Fig. 2c). Ensure that the outlet of the Tastic is directed towards the outer wall. If the desired orientation of the Tastic unit directs the ducting across ceiling joists ensure that the closest ceiling joist is not within 200 mm of the Tastic outlet.

Figure 2a

A: 215 mm **B:** 15 mm min. clearance above unit

Figure 2b

C: 15 mm **D:** 166 mm **E:** 35 mm **F:** 200 mm min.

Figure 2c

20 mm min. clearance is required near all joists

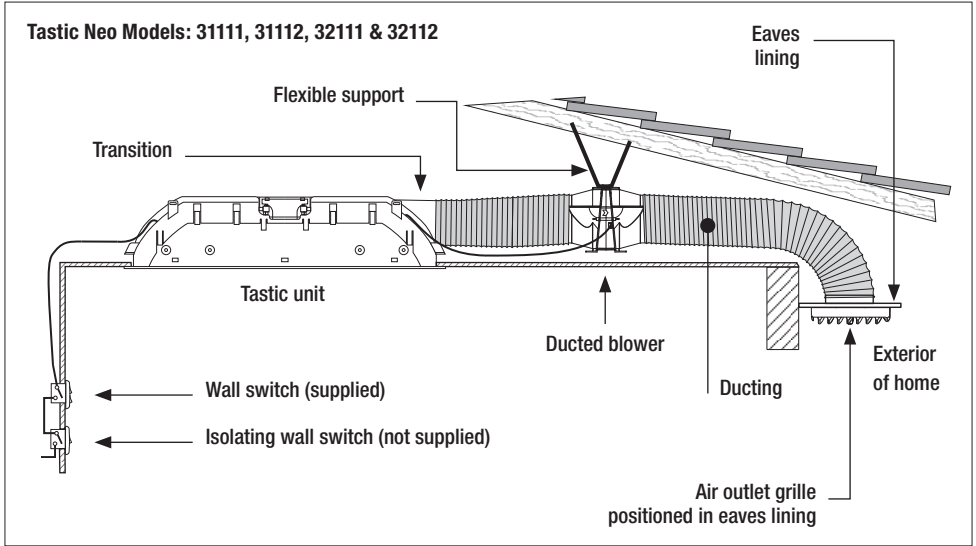

Fig. 3: Layout of Tastic Neo Single and Dual.

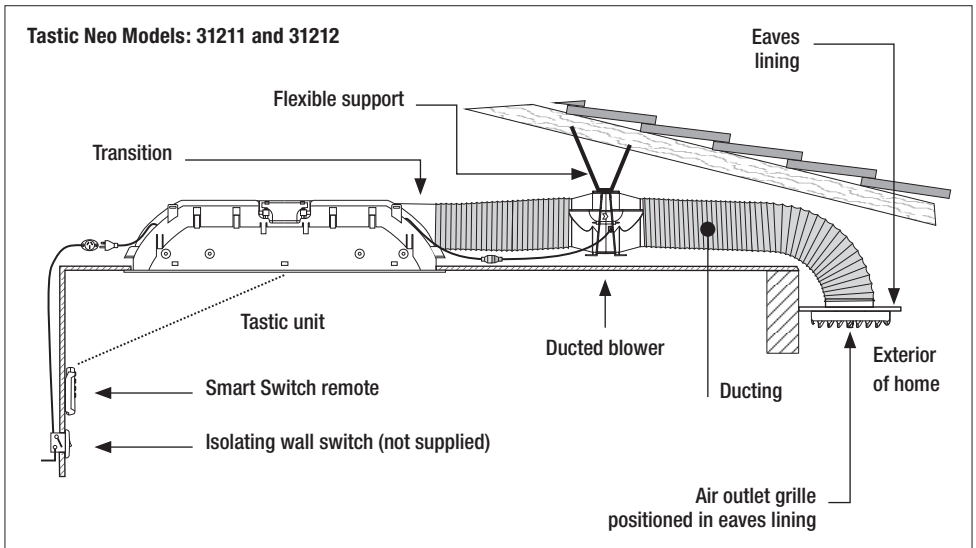

Fig. 4: Layout of Tastic Neo Smart Switch Single.



Tastic Neo units are fitted with CFL centre lamps. To ensure correct operation and to prolong the life of the CFLs please wire as per the following wiring diagrams for the appropriate model.

See the wiring diagrams on the following pages for supply requirements and maximum loadings for each model. Tastics may be connected to a lighting or power circuit if loading permits. These models are for wired-in installation and wiring must be carried out by a registered electrician. *Switches and a wall plate are provided with the hardwired Tastic Neo's. A remote control is provided with the Smart Switch models. Do not use this product with any solid state speed control or commercial dimming device.

NOTE: The *Permanent Active Connection* must be provided on the hardwired models so the unit can function as it was designed to do so.

* Number of switches depends on your Tastic model.

Wiring Diagrams

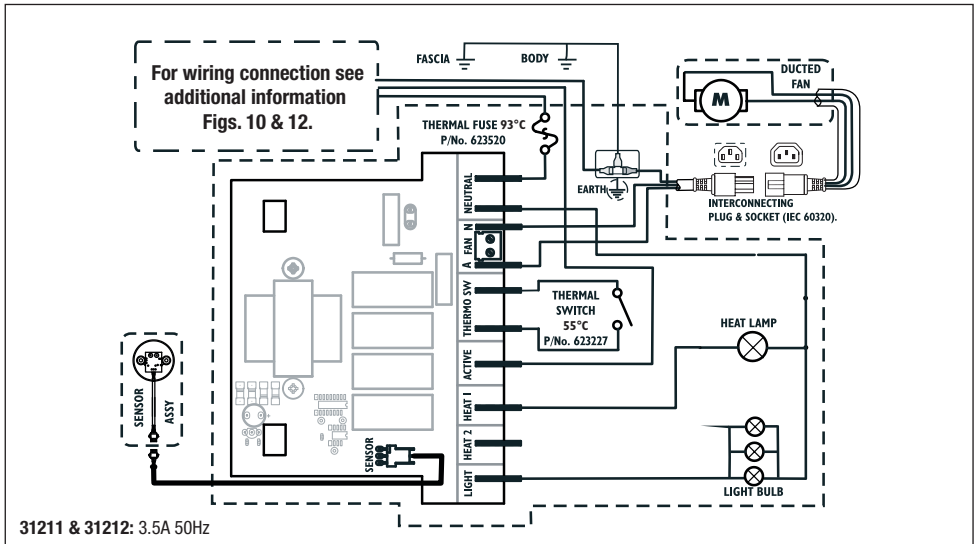

Fig. 5: Wiring diagram for models 31211 and 31212.

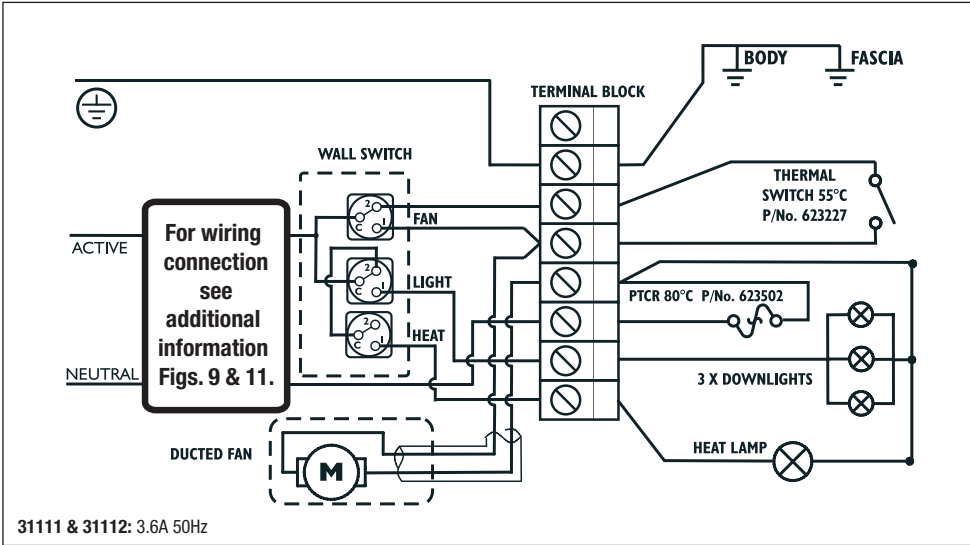

Fig. 6: Wiring diagram for model 31111 and 31112.

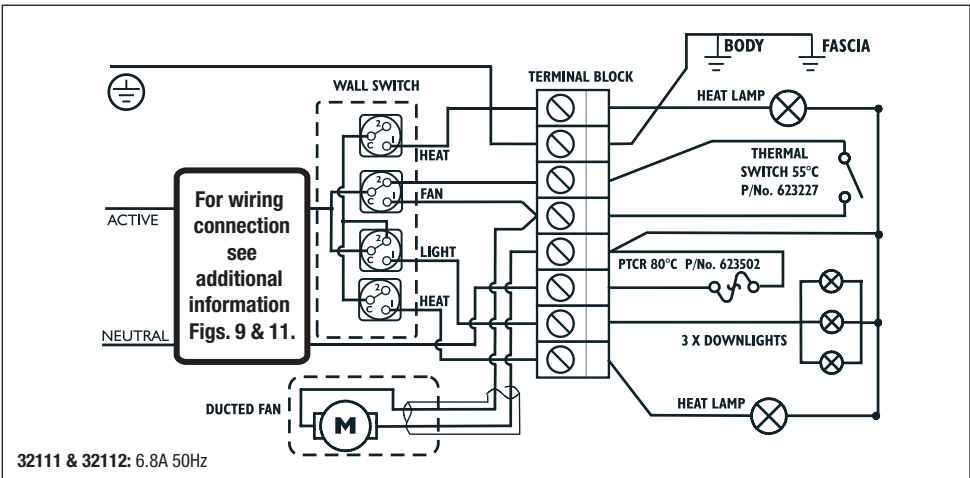

Fig. 7: Wiring diagram for model 32111 and 32112.

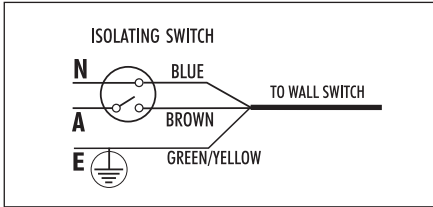

Fig. 8: Hardwired

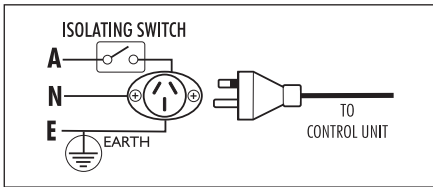

Fig. 9: Smart Switch

Hardwired models 31111, 31112, 32111 & 32112:

A local isolating switch (not supplied) must be incorporated in the fixed wiring to the appliance to allow disconnection of supply during maintenance. This isolating switch should be located in close proximity to the Tastic and must be installed in accordance with applicable Wiring Codes.

Smart Switch models 31211 & 31212: Switch the power outlet for the Control Unit with a wall switch (not supplied) as per Fig. 9. Do not mount the power outlet for the Control Unit more than 200 mm from the Tastic.

In both versions the wall switch should be located in accordance with Wiring Rules AS/NZS 3000. It must not be installed where it can be reached from the bath recess or enclosure (see AS/NZS 3000 Section 7).

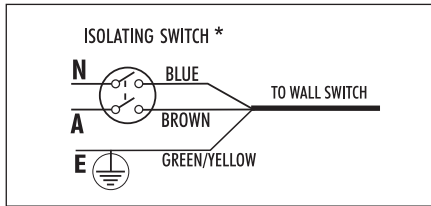

Fig. 10: Hardwired

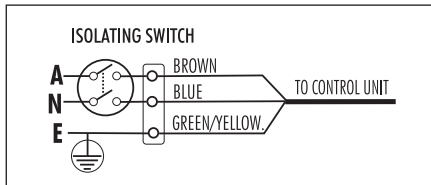

Fig. 11: Smart Switch

* This isolating switch must be double-pole type with minimum 3 mm contact gap.

Hardwired models 31111, 31112, 32111 & 32112:

The wall switch should be located in accordance with the applicable Wiring Rules and it must not be installed where it can be reached from the bath or shower recess or enclosure.

Smart Switch models 31211 & 31212: Supply should be connected to the Tastic 3-core power lead as per the diagram below. The plug fitted to the power cord is to be cut off and the wires stripped to allow connection. See Fig. 10.

A local isolating switch (not supplied) must be incorporated in the fixed wiring to the appliance to allow disconnection of supply during maintenance. This isolating switch should be located in close proximity to the Tastic and must be installed in accordance with applicable Wiring Codes.

The colours of the wires in the Tastic 3-core lead may not correspond to those in the fixed wiring. The designation of poles for the Tastic power leads are as follows:

Tastic Wire Colour	Connect to Supply Pole
Brown	Live
Blue	Neutral
Green / Yellow	Earth

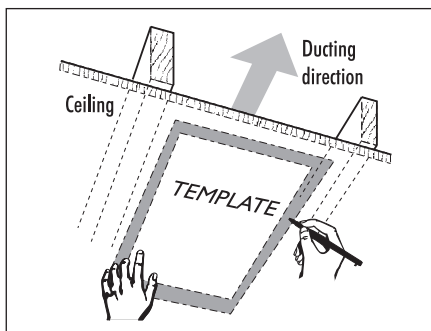

Fig. 12: Use template to mark position of Tastic

Installation

The Tastic may be installed between joists using the supplied toggle bolts, clearances for the two vertical sides must be maintained as per Fig. 2c on page 7.

IMPORTANT: Joists, beams and rafters shall not be cut or notched to install the appliance.

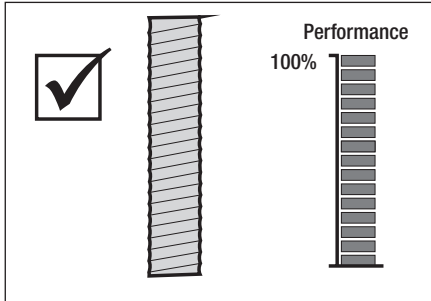

Fig. 13: Straight ducting

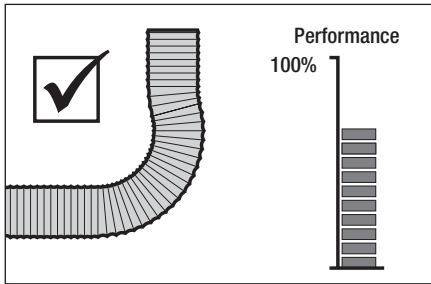

Fig. 14: Gradual bends, ducting stretched straight

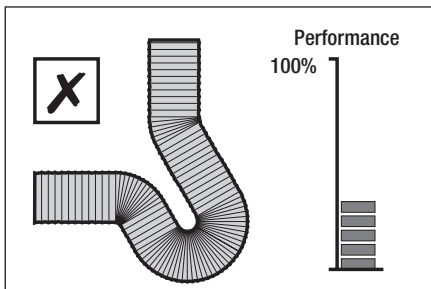

Fig. 15: Tightly compressed bends

Depending on your model, the Tastic has a weight of 5 – 9 kg (see below). If adequate support is not available for the Tastic, it may be necessary to provide extra strengthening.

Neo Single – approx 5 kg

Neo Dual – approx 9 kg

If ceiling battens have been cut to install this product then ensure that the cut ceiling battens are adequately secured to rafters.

NOTE: This product must be installed by a qualified installer. Ensure power is off to location of Tastic.

Cut out hole for Tastic body

1. After determining the location of components according to the directions, mark out and cut aperture in ceiling for Tastic NEO unit using the template supplied with the Tastic. Trim the template to the outside of the black outline allowing for the four rectangular notches.
2. Unscrew terminal cover on Hardwired models.

Ducting

1. These products have been designed to suit 150 mm dia. ducting. Determine the length of ducting required ensuring that the length is as short as possible. Refer to Fig's 13-15 to attain optimum performance.
2. Tape a length of ducting 1 m long (max) between the blower inlet and the Transition. Tape remaining length of ducting to exit of blower.

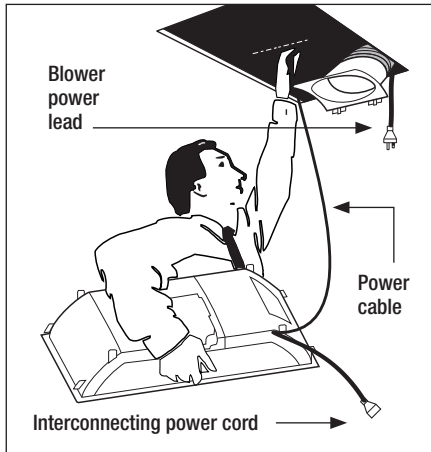

Fig. 16

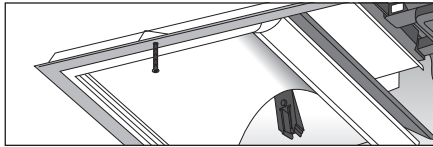

Fig. 17

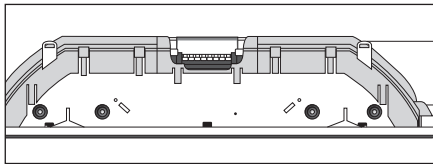

Fig. 18

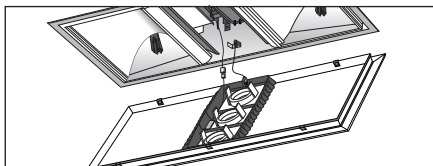

Fig. 19

Installing the Ducted Blower

NOTE: The transition is assembled to the main body before the main body has been snapped into place in the ceiling.

1. Feed ducting and blower through hole in ceiling. While feeding ducting into ceiling direct it towards the installation position of the outlet grille. Position blower so that the short length of ducting is stretched out and Transition piece along with stripped or terminated wire is sitting next to the hole as per Fig. 16.
2. Make the necessary electrical connections.

Smart switch models: Connect ducted blower power cord into interconnecting socket provided and connect power cord to socket outlet.

Hardwired models: Connect ducted blower power cord to terminal block as per wiring diagram and connect wall switch to terminal block as per circuit diagram.

Final Assembly

1. Clip transition to the body, ensuring that the ducting taped to the transition is not dislodged. Position the Tastic body into the aperture, so that the plastic end supports are resting on the plaster. As the Tastic is raised into ceiling, ensure electrical cables do not rest over Tastic. Place the four toggle bolts through the recesses cut into the plaster, (Fig. 17) and tighten the bolts. This will raise the Tastic body flush to the ceiling (Fig. 18).
2. Bring fascia assembly up to the Tastic body. (Fig. 19) Connect the earthing wire to the fascia and connect the IR sensor lead (Smart Switch models).
3. Clip fascia into the Tastic body.
4. Using care, fit the tubular heat lamps into the lamp holders. Be careful not to touch the glass surface as oils from skin can shorten the life of the glass lamp. A clean soft cloth or tissue is recommended. Ensure that the white reflective

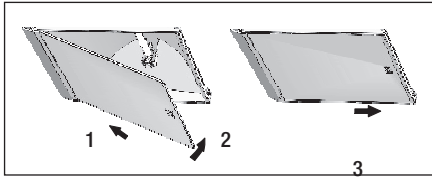

Fig. 20

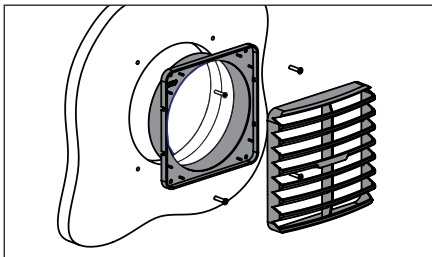

Fig. 21

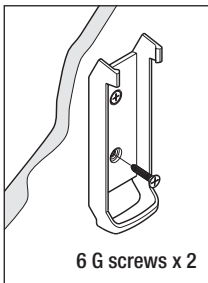

Fig. 22

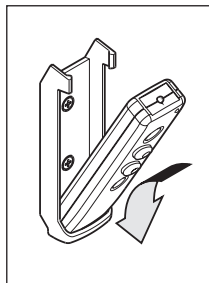

Fig. 23

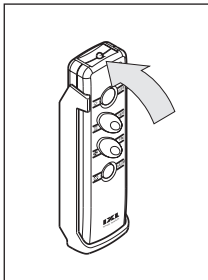

Fig. 24

layer on the tubular heat lamp is on the upper side of the lamp, ie lamp is pointing downwards.

5. Clip the downlight mounts into the fascia.
6. Fit the glass sheets to the heat lamp reflector bodies Fig. 20.
7. Ensure that the dip switches in the hand set are correctly set for your local ventilation requirements Fig. 26-27 (pages 16-17).
8. Turn on the power at the isolating switch and check operation of the Tastic.

Installing the Grille

1. Cut a hole 160 mm in diameter in eaves or outer wall. Feed ducting out through this hole and tape to the Grille baseplate.
2. Feed the ducting back through the hole so that the Grille base is against the eaves or outer wall.
3. Fix Grille base with four 6 G screws and snap fit the Grille louvres over the Grille base as shown in Fig. 21.

Mounting the Smart Switch Remote Remote Cradle

1. Select a suitable position for the Easy Duct Smart Switch Remote cradle.
2. Check that the sensor will receive signals from the remote in the location you have selected.
3. At the position selected for the cradle to be mounted, mark the positions of the two screw holes. If mounting into plasterboard or masonry you may require specific wall plugs or masonry anchors (not included) to provide suitable support for the cradle and remote.
4. Screw the cradle to the wall using 2 of 6 G screws (not supplied) and tighten screws (Fig. 22)
5. Swing the top of the handset into the cradle (Fig. 23 - 24.)
6. Check the operation of all Tastic functions.

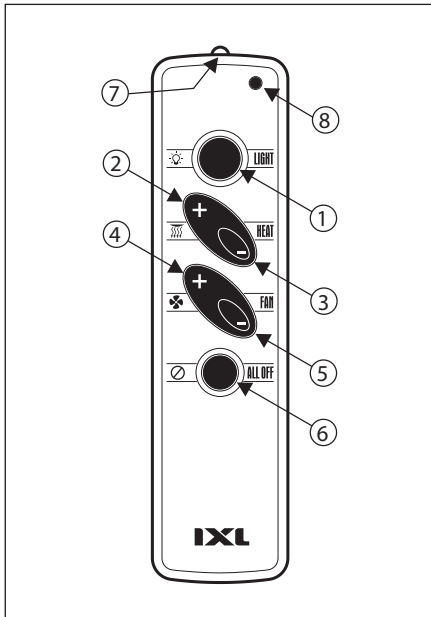

Fig. 25

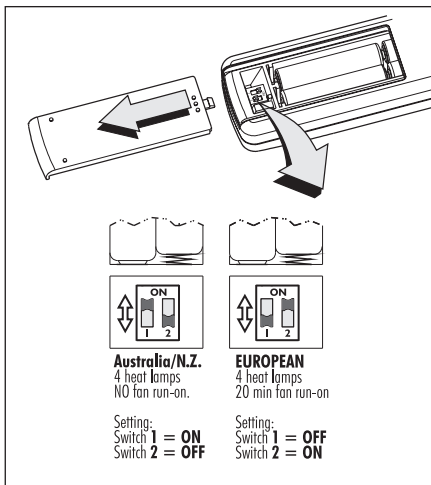

Fig. 26

The Smart Switch system and functions

All functions are controlled by the Smart Switch (Fig. 25), a battery powered wall mounted remote unit that sends an Infra red (IR) signal to a receiver mounted in the Tastic Neo fascia. Subsequent signals go to the Control Unit mounted on the top of the Tastic Unit.

NOTE: While the heat lamps are turned **ON**, the centre lamps are turned **OFF**.

1. Switch the centre light **ON** or **OFF**.
2. Switch heat lamp **ON**.
3. Switch heat lamp **OFF**.
4. Pressing this button once will switch **ON** the **FAN**.
5. Switches the **FAN OFF**.
6. Switches **ALL** functions **OFF**.
7. IR transmitter.
8. Transmitter indicator.

Remote dip switch settings

The factory preset of the Dip Switches is for Europe (20 min fan run-on), all other country/regions are to reset dip switches as per local ventilation requirements. Recommended settings as per details shown in Figs. 26 & 27.

NOTE: The Smart Switch handset is not water resistant. Do not immerse the Smart Switch in water or allow water to splash on the Smart Switch.

Initial Power Up

Upon initial connection to mains voltage, the centre lights will be switched on automatically for a minimum of 2 mins.

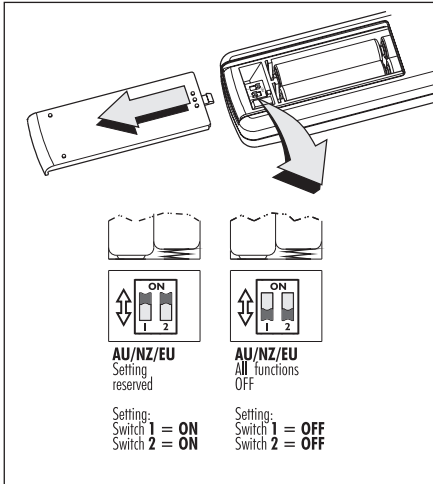

Fig. 27

40 Minute Delay Off

This Tastic has a power saving feature which will automatically switch off all functions except the centre lights approximately 40 minutes after the last signal is received from the IR remote handset, provided the last signal was one of the following button operations: FAN +, FAN -, HEAT + and HEAT -.

20 Minute Auto Run-on Fan (Required in European Countries)

This Tastic includes an automatic run-on for the fan. Each time the fan is switched on, it will run for a minimum of 20 minutes. If you switch the fan OFF during this time, the fan will run-on for the remainder of the 20 minutes. If you switch the fan OFF after the fan has run for at least 20 minutes, the fan will stop. See Fig. 26 for handset switch settings.

Replacement Batteries

Smart Switch – 4 x AAA / 1.5 V / UM-4 batteries
IXL Cat. No. 626655

Batteries supplied with the Smart Switch are not covered by the manufacturer's warranty.

NOTE: All four batteries should be replaced together when necessary – do not use old batteries with new batteries.

Parts

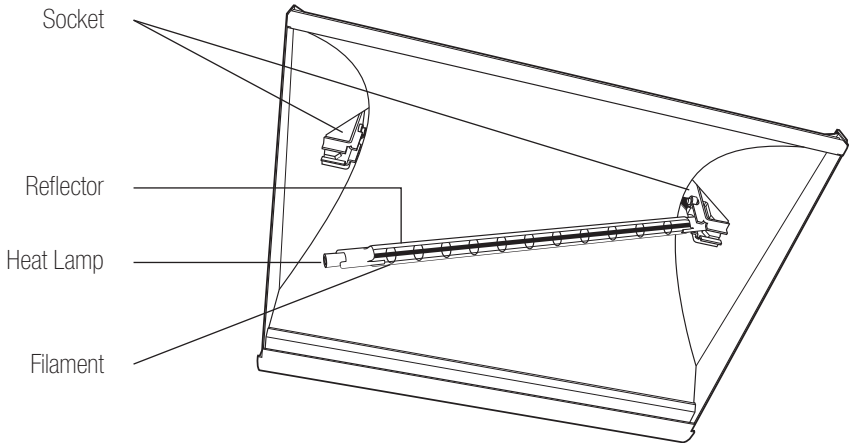

Preparing

Turn the heat lamp off and let it cool for at least 5 minutes. For extra safety, switch the power off at the isolating switch.

Position a sturdy ladder of sufficient height to let you safely and comfortably reach the Tastic Neo. Ask someone to hold the ladder if you can.

Removing Glass Shield

With one hand, gently press the glass shield (at a point close to the air inlet) 2 mm towards the ceiling and carefully slide it towards the air inlet.

Hold your other hand below the other end of the shield to catch it when it drops.

If the shield chips, cracks or breaks, do not use the heat lamp without it. Replace it with IXL Tastic® Neo Tempered Glass Shield Part 12200, not normal household glass.

Removing Old Heat Lamp

A spring-loaded socket holds each end of the heat lamp.

Gently grasp the heat lamp and push it towards one socket.

When it is free of the other socket, carefully pull the heat lamp down towards you.

The heat lamp is not recyclable. Dispose of it like a normal incandescent light globe (i.e. unbroken, with your general waste, wrapped in any paper or cloth you used).

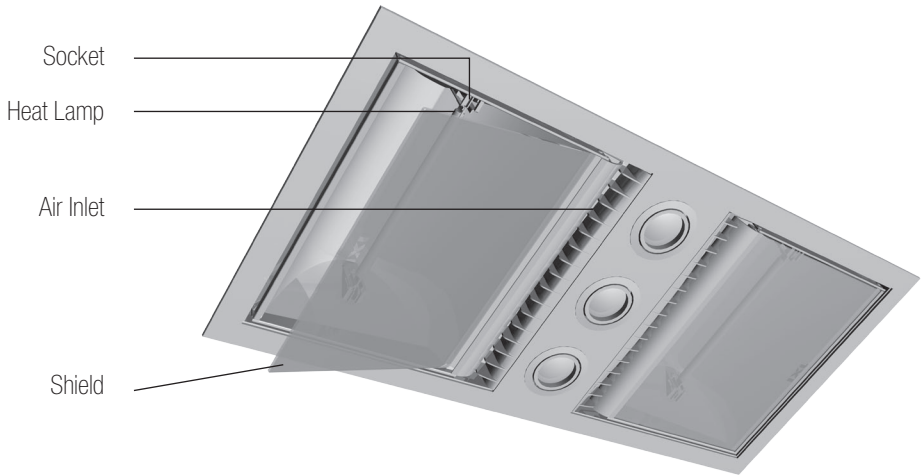

Fitting New Heat Lamp

Natural skin oils and salts damage new halogen lamps and shorten their life. Only handle a new heat lamp with soft, dry, clean, lint-free cloth or paper. You can wear gloves, cover your fingers or wrap the heat lamp until it is installed (so long as you remove all cloth or paper when finished).

If your skin touches a new heat lamp, wipe it gently with alcohol-moistened cloth or paper.

The heat lamp is half coated with a white reflector. When you grasp the heat lamp, face the back of the reflector to the ceiling (so you can see the heat lamp's filament). Not doing this will reduce performance.

Fit one end of the heat lamp into a socket and gently push it away from the other socket.

When there is enough room, fit the other end of the heat lamp into its socket.

Gently rotate the heat lamp to ensure it is correctly seated (i.e. it looks like the old one did before you removed it).

Replace the shield by reversing the directions for removing it.

Switch the power on and test the heat lamp.

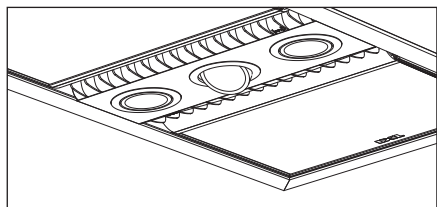

Fig. 28

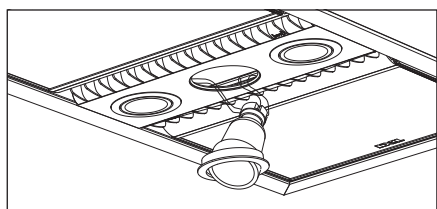

Fig. 29

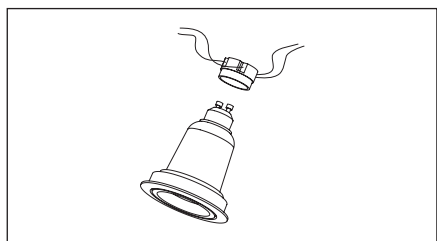

Fig. 30

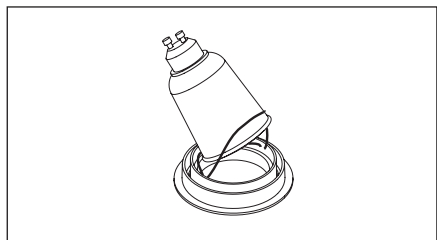

Fig. 31

Step 1 – Figure 28

Tilt the lamp ring.

Step 2 – Figure 29

Grip the lamp ring and pull lamp fitting away from fascia.

Step 3 – Figure 30

Twist the lamp holder to separate from the lamp.

Step 4 – Figure 31

Remove the lamp from the lamp ring.

Step 5

Reverse the steps above to re-fit the lamp.

NOTE: Replacement with any other lamps other than those listed below may cause damage to the Tastic Neo and void the warranty.

Heat Lamps

The IXL Tastic lamps have been specially developed for best performance.

R7s, 258mm long, 800W max. IXL Cat No. 11380

NOTE: Replace only with genuine IXL approved infra red halogen heat lamps.

Light Bulb

GU10 9W CFL Cat No. 12250

Light bulb is not covered by manufacturer's warranty.

NOTE: These lamps can be replaced with Halogen lamps, 50W maximum.

Cleaning & Maintenance

WARNING: Always make sure the unit is turned off and allow all bulbs to cool before cleaning.

Maintenance of the Tastic Neo is required to ensure the quality of the product and functions are maintained.

It is recommended that the Tastic Neo body, fascia and globes be checked and cleaned every 2 years.

To clean the fascia and air inlet use a damp cloth with liquid glass cleaner.

Cleaning and maintenance will help to preserve the life-span and performance of the Tastic Neo.

Service

NOTE: Do not remove the Tastic Neo from the ceiling. Your Tastic Neo will be serviced in your home. If service is required, please contact IXL's Service Centre on 1300 727 421.

Frequently asked questions

Q – Will my Tastic Neo heat my bathroom?

A – No your Tastic Neo is designed to provide infra red radiant heat to warm the body while drying, when standing directly underneath. It is not designed as a room heater.

Q – Can I install my Tastic Neo directly above a shower recess?

A – For safety reasons it is not recommended to install above shower recess. Please refer to the current Australian/New Zealand Wiring Rules AS/NZS 3000 relating to damp situations for further details.

Q – What is the maximum recommended light globe wattage that I can install in my Tastic?

A – 50W Halogen GU10 downlights can be installed in a Tastic Neo.

Q – What will happen if I leave my heat lamps on without fan operation?

A – The fan will commence operation automatically to keep the unit operating at a safe temperature. When the unit has cooled sufficiently the fan will switch off automatically.

Q – Why is my Tastic Neo making noise?

A – All Tastics create some noise due to the rapid movement of air through the Tastic.

Q – Can I retro fit a remote control to my existing hardwired Tastic Neo?

A – No, unfortunately this is not possible.

Q – Can the installer rotate the IXL wall switch mechanisms?

A – Yes, the wall switches can be rotated by a qualified electrical trades person.

Q – Can my installer use an alternative wall switch mechanism other than the one supplied with my IXL product?

A – Yes, your authorised installer can use an alternative switch mechanism.

- Q** – My Tastic unit's extraction fan doesn't seem to be removing all the moisture and steam from my bathroom?
- A** – There are a number of factors that will influence the exhaust fan's performance. Firstly you can improve your cross ventilation via an open door or window; refer to page 7 of the instructions for details on improving the room's air flow.

If you live in a traditionally cooler climate, in the winter months during hot showers, you may notice that there is more moisture and condensation build up. If this is the case, you may wish to improve your natural ventilation or invest in an additional exhaust fan.

Bathrooms which have high ceilings, are larger than average, or have an open shower may all require additional ventilation. We recommend that you visit our website for further details and suggestions on effectively ventilating your bathroom.

IXL Range: Tastic and Ventilation

Within the IXL Tastic and ventilation range there are a number of products and optional accessories available, these include:

- Tastic 3 in 1: Heat, Light and Fan
- Tastic 2 in 1: Light and Fan
- Ducted Tastics
- Ventilation Fans
- Ventilation and Light Units
- Eco Tastics
- Remote controlled Tastics (Smart Switch)
- Easy Duct Thermal Transfer System
- Tastic Neo

IXL Range: Accessories

- Genuine IXL Heat Lamps
- Centre Globes
- In line Ducting
- Grilles and Fascias

For more information or help, please contact Sampford IXL on 1300 727 421 or visit the website at www.sampfordixl.com.au

**RECORD THE DETAILS OF YOUR MODEL AND KEEP THE FOLLOWING INFORMATION
DO NOT SEND THIS TO IXL.**

Installed By

Suburb

Date of Purchase

Model No. Serial No

This Warranty against defects for your newly purchased Tastic product is proudly prepared by Sampford IXL Pty Ltd of 421 Smith Street, Fitzroy, VIC 3065, phone 1300 727 421.

1. Sampford IXL Tastic products come with guarantees that do not exclude the following consumer entitlements under the Australian Consumer Law:
 - a. replacement or refund for a major failure and compensation for any other reasonably foreseeable loss or damage; and
 - b. to have the goods repaired or replaced if goods fail to be of acceptable quality and the failure does not amount to a major failure.
2. Sampford IXL warrants that your product and related supply will be free from defects in materials and workmanship during the warranty term. Your warranty term is five years with a two year heat lamp replacement warranty, commencing from the date of purchase. Sampford IXL acknowledges this product requires professional installation and product removal is hazardous to consumers, accordingly any necessary inspections and services will be carried out on site. You should not attempt de-installation.
3. Subject to Point 1, Sampford IXL will repair any defects in materials and workmanship during the warranty term and if the product is deemed irreparable provide a replacement of an equivalent current model where the balance of the warranty period from the original date of purchase will take effect.
4. To the fullest extent permitted by law and subject always to Point 1, Sampford IXL will not be liable for:
 - a. any loss or damage arising from loss of use, loss of profits or revenue; or
 - b. for any indirect or consequential loss or damage resulting from any breach of this warranty against defects.
5. Defective Sampford IXL Tastic products may be repaired using refurbished parts or if required, completely replaced by a refurbished product of the same type.

Limitations to Your IXL Warranty

6. Subject to Point 1, this Warranty:
 - a. will only be provided to the original purchaser where the original purchase was made from a Sampford IXL Authorised Dealer or Reseller and proof of such purchase can be presented at the time of service;
 - b. only applies to Sampford IXL Tastic products purchased in Australia from a Sampford IXL Authorised Dealer or Reseller and installed by a qualified person where a Certificate of Compliance in accordance with State/Territory laws is provided;
 - c. will not apply where the defect in or failure of the product is attributable to misuse, abuse, accident or non-observation of the manufacturer's instructions. This product must be used in accordance with the manufacturer's instructions;
 - d. will not cover faults due to normal wear and tear with reasonable use nor consumable components such as globes, filters, glass items, etc;

- e. will not cover any damages or problems caused to this product by natural forces eg. storm, fire, flood, and earthquake; or by intrusion or accumulation (or both) of foreign matters eg. dust, soil, and moisture. Sampford IXL recommends that you take out appropriate insurances to protect your product to this end;
- f. will not apply if this product is installed in a mobile dwelling eg. caravan or boat;
- g. will not apply if this product is removed from the location where it was first installed;
- h. is immediately void if the serial or model number label is removed or defaced;
- i. is immediately void if the product is serviced or repaired by a unauthorised/unqualified personnel;
- j. covers use of this product for domestic use only;
- k. will not be restarted or extended upon repair or replacement of the product or a part.

How to make a Claim under Your IXL Warranty

- 7. To make a claim under this Warranty you will need to:
 - a. contact Sampford IXL service department on 1300 727 421 or aftersaleservice@sampfordixl.com.au to provide details and register your claim enabling a Sampford IXL assessment;
 - b. submit proof of purchase with your claim eg. tax invoice or purchase receipt;
 - c. where a property has been constructed by a builder/developer and it is fitted with IXL products, please submit proof of purchase by way of the certificate of occupancy, with your claim.
- 8. Sampford IXL will contact you to make arrangements for service on site.
- 9. Subject to Point 1, you will be responsible for any costs relating to the provision of your product to a Sampford IXL Authorised Service Dealer.
- 10. Subject to Point 1, in the event you live more than 50 km from a Sampford IXL Authorised Service Dealer you may be subject to travel or transport costs to facilitate the repairing or replacement of your IXL product.
- 11. Sampford IXL and its Authorised Service Dealers reserve the right to seek reimbursement of any costs incurred by them should your IXL product be found to be in good working order.

Privacy

The privacy of your personal information has always been important to us. To learn more about how we collect, keep and use your personal information, please obtain a copy of our privacy statement by visiting our website at www.sampfordixl.com.au or by contacting us via email on info@sampfordixl.com.au or by telephone on 1300 727 421.

For comments, questions or warranty matters:

Sampford IXL Pty Ltd

Service Department

421 Smith St

Fitzroy Victoria 3065 Australia

Phone: 1300 727 421

Fax: 1300 727 425

aftersaleservice@sampfordixl.com.au

info@sampfordixl.com.au

www.sampfordixl.com.au



Approved by the appropriate electrical supply authorities.