

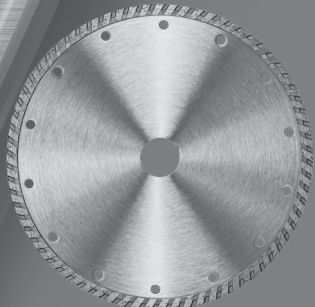

200MM TURBO DIAMOND TILE CUTTING BLADE

- 25.4MM BORE DIAMETER
- STEEL WITH DIAMOND CUTTING EDGE
- FOR FAST, WET CUTTING APPLICATIONS
- IDEAL FOR CONCRETE, BRICK OR LIMESTONE
- SUITS FBT-8800 RADIAL TILE CUTTING SAW



INSTRUCTION MANUAL

WARNING: Read all safety warnings and all instructions. Failure to follow the warnings and instructions may result in electric shock, fire and/or serious injury. Save all warnings and instructions for future reference.

1018

SPECIFICATIONS - MODEL NO. FBATTB-200

Blade dimensions:	Ø 200 x 2.8 mm
Bore diameter:	25.4 mm
Blade speed max.:	7600 rpm
Linear blade speed max.:	80 m/s
Weight:	0.39 kg

INTRODUCTION

Congratulations on purchasing a Full Boar Turbo Diamond Tile Cutting Blade.

This blade is a suitable replacement blade for the FBT-8800 Full Boar Radial Tile Cutting Saw. It is designed for DIY applications and craft businesses in particular. It should never be used for the cutting of wood or metal.

TILE CUTTING BLADE SAFETY WARNINGS

WARNING! This accessory is not intended for use by persons (including children) with reduced physical, sensory or mental capabilities, or lack of experience and knowledge, unless they have been given supervision or instruction concerning use of the appliance by a person responsible for their safety.

Specific Warnings for Tile Cutting Blades:

- This blade is intended for wet cutting applications only. Make sure the cutting disc is cooled with water during the complete cutting process. Follow your tile cutter instructions for performing wet cutting operations.
- Never carry out dry cuts with cutting discs designed for wet cutting.
- Do not grind/cut material for which the product is not designed.
- Do not feed the tile into the machine any faster than the cutting disc can cut.
- Before you install the cutting disc, check the spindle, spindle nut and flanges for damage or a loose fit. Replace damaged or worn parts without delay.
- Make sure the directional arrow on the cutting disc coincides with the rotational direction of the motor shaft.
- Make sure that the diameter of the hole in the cutting disc conforms with the diameter of the cutting disc spindle on the machine.
- Do not exceed the safe operating speed of the cutting disc.
- After switching off the machine, the cutting wheel needs 40 seconds before coming to a standstill. Wait until the cutting wheel has stopped completely, then pull the power plug out of the socket outlet and, if necessary, only then touch the machine's rotating components.
- Do not stop the disc by applying pressure to its surface, let it come to a stop naturally.
- Avoid touching the rotating cutting wheel at all when the machine is in operation.
- **Wear safety goggles - Wear ear-muffs - Wear safety gloves.**
- Do not wear loose clothing or accessories while operating the machine.
- Never use cracked diamond cutting wheels. Replace immediately.
- Stop using the product if vibration occurs. True or replace the blade.
- Always pull out the power plug before changing the cutting wheel.
- When removing an accessory from the tool avoid contact with skin and use proper protective gloves when grasping the blade. Accessories may be hot after prolonged use.
- Do not tighten the mounting device excessively.
- Never leave the machine unattended in rooms with children. Young children should be supervised to ensure that they do not play with the appliance.
- Store cutting discs in dry, frost-free conditions, avoiding wide variations in temperature.
- Avoid clogging and uneven wear to ensure the product works efficiently.
- Do not use this product near flammable materials.

WARNING! Some dust created by power sanding, sawing, grinding, drilling and other construction activities contain chemicals known to cause cancer, birth defects or other reproductive harm.

Some examples of these chemicals are:

- Lead from lead-based paints;
- Crystalline silica from bricks, cement and other masonry products, and;
- Arsenic and chromium from chemically-treated timber.

The risk from such exposures vary depending on how often you do this type of work. To reduce your exposure to these chemicals; work in a well ventilated area, and work with approved safety equipment, such as those dust masks that are specifically designed to filter out microscopic particles.

Always wear eye protection and a dust mask for dusty applications. Sanding particles can be absorbed by your eyes and inhaled easily and may cause health complications.

MOUNTING INSTRUCTIONS

WARNING! Ensure the tile cutter is disconnected from the power supply before performing the following operations.

Changing the Tile Cutting Blade

1. Pull out the power plug.
2. Unscrew the three screws on the safety hood and remove from the cutting wheel (Fig. 1).
3. Using a wrench, loosen the flange nut in the direction of rotation of the cutting wheel. (**Note.** Left-hand screw-thread.) To do so, place the supplied wrench on the motor shaft and apply counterpressure (Fig. 2).
4. Remove the outer flange and cutting wheel (Fig. 3).
5. Clean the mounting flange thoroughly before fitting the new cutting wheel.

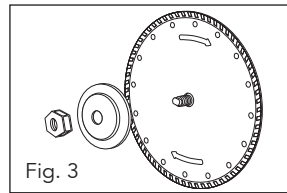
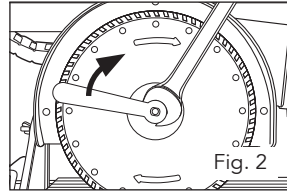
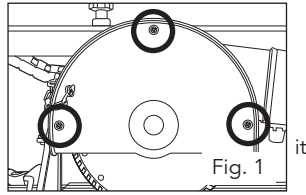

CAUTION! Pay attention to the direction of rotation of the new cutting wheel when mounting!

6. Fit the new cutting wheel by following the above procedures in reverse and then tighten the flange nut.
7. Mount the safety hood for the cutting wheel again.

DESCRIPTION OF SYMBOLS

rpm	Revolutions or reciprocation per minute	m/s	Metres per second
∅	Diameter		Abrasive product only suitable for wet cutting
	Disconnect from power before changing blades		Do not touch spinning blade
	Wear ear protection		Wear eye protection
	Wear hand protection		

CARING FOR THE ENVIRONMENT



Power tools that are no longer usable should not be disposed of with household waste but in an environmentally friendly way. Please recycle where facilities exist. Check with your local council authority for recycling advice.



Recycling packaging reduces the need for landfill and raw materials. Reuse of recycled material decreases pollution in the environment. Please recycle packaging where facilities exist. Check with your local council authority for recycling advice.

Distributed by:
Ozito Industries Pty Ltd

AUSTRALIA (Head Office)

1-23 Letcon Drive, Bangholme Victoria, Australia, 3175

Telephone: 1800 069 486