



# ***BANDSAW***

- ***245mm***
- ***420W POWER***
- ***2 SPEED***
- ***HEAVY DUTY STAND***



## ***INSTRUCTION MANUAL***

 **WARNING:** Read all safety warnings and all instructions. Failure to follow the warnings and instructions may result in electric shock, fire and/or serious injury. Save all warnings and instructions for future reference.

## SPECIFICATIONS - MODEL NO. FBT-2450

<b>Power:</b>	420W
<b>Input:</b>	220-240V ~ 50Hz
<b>No Load Speed:</b>	1400/min-1
<b>Throat Depth:</b>	245mm
<b>Blade Length:</b>	1790mm
<b>Blade Width:</b>	6-13mm
<b>Max Cutting Height:</b>	120mm
<b>Blade Speed:</b>	660 / 960 m/min
<b>Table Size:</b>	300x330mm
<b>Weight (tool only):</b>	33kgs

## KNOW YOUR PRODUCT

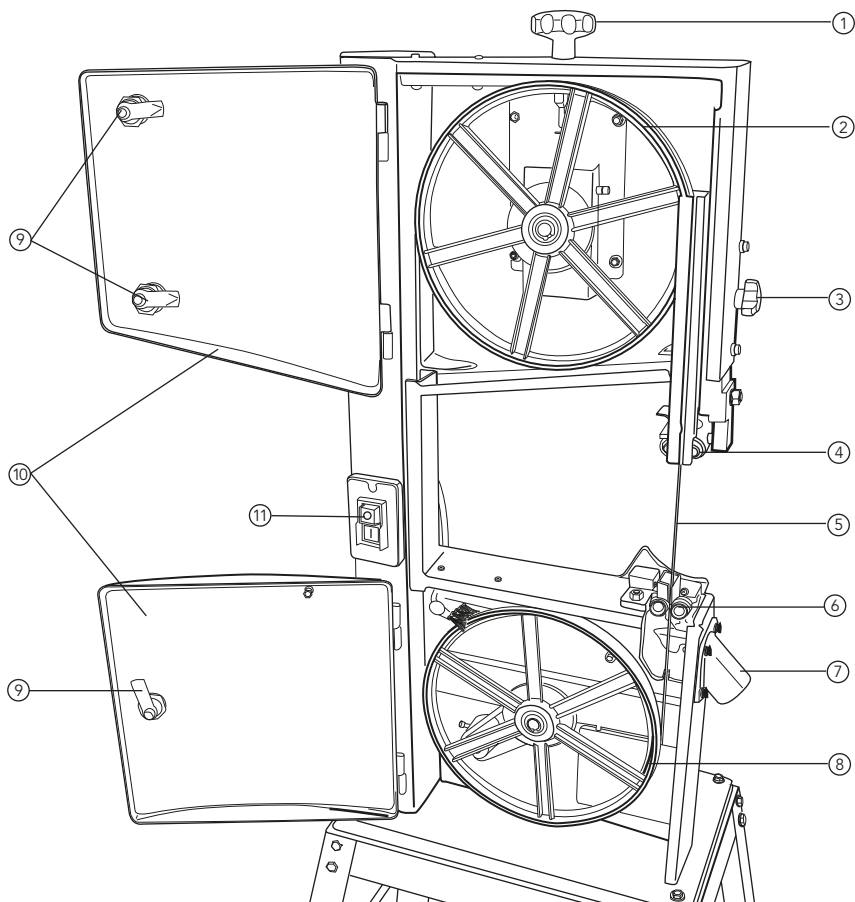

# KNOW YOUR PRODUCT

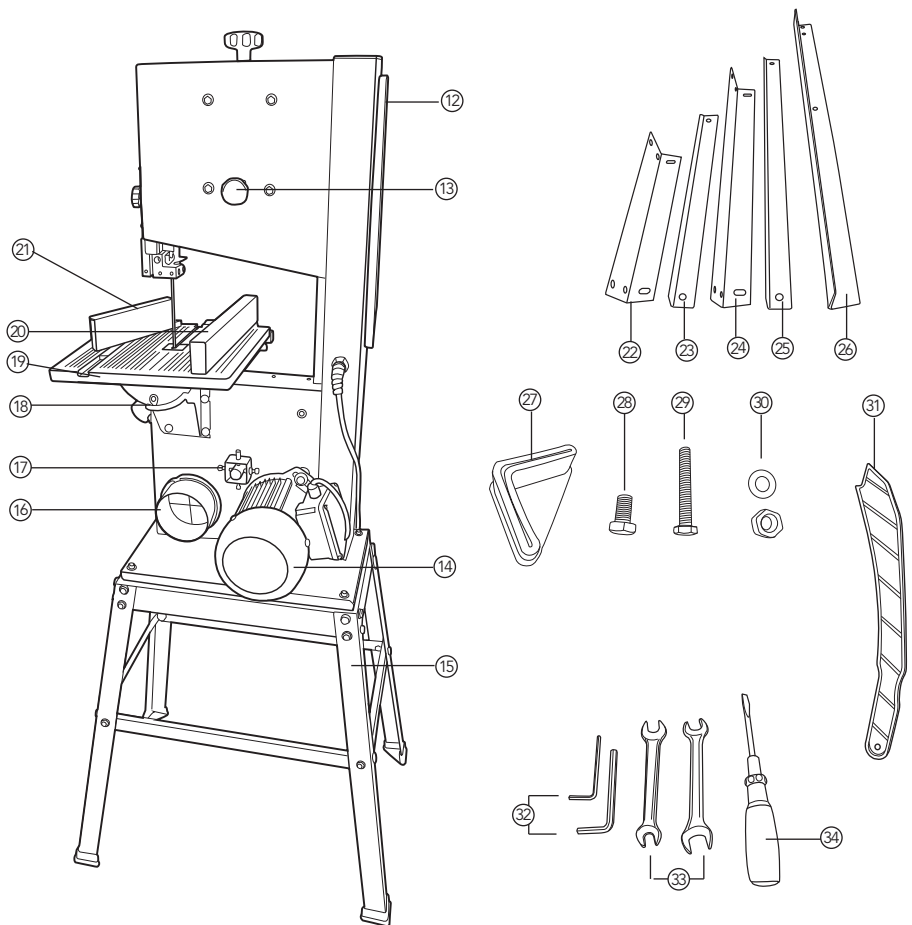

- |                                   |                                    |                           |
|-----------------------------------|------------------------------------|---------------------------|
| 1. Blade Tension Knob             | 13. Blade Tracking Knob            | 25. Long Side Support x 2 |
| 2. Upper Wheel                    | 14. Motor                          | 26. Leg x 4               |
| 3. Upper Blade Guide Knob         | 15. Stand                          | 27. Rubber Feet x 4       |
| 4. Upper Blade Guide              | 16. Dust Extraction Outlet (Large) | 28. Bolt (short) x 24     |
| 5. Blade                          | 17. Lower Wheel Locator            | 29. Bolt (long) x 4       |
| 6. Lower Blade Guide              | 18. Bevel Angle Pointer            | 30. Nut & Washer          |
| 7. Dust Extraction Outlet (Small) | 19. Saw Table                      | 31. Push Stick            |
| 8. Lower Wheel                    | 20. Rip Fence                      | 32. Hex Keys x 2          |
| 9. Door Lock                      | 21. Mitre Fence                    | 33. Spanners x 2          |
| 10. Housing Door                  | 22. Short Upper Support x 2        | 34. Screwdriver           |
| 11. On/Off Switch                 | 23. Short Side Support x 2         |                           |
| 12. Push Stick Holder             | 24. Long Upper Support x 2         |                           |

## TABLE OF CONTENTS

SPECIFICATIONS.....	Page 2
KNOW YOUR PRODUCT.....	Page 2
INTRODUCTION.....	Page 5
SAFETY INSTRUCTIONS.....	Page 5
ASSEMBLY.....	Page 10
OPERATION .....	Page 13
MAINTENANCE .....	Page 19
CONTENTS .....	Page 21
WARRANTY.....	Page 22

## INTRODUCTION

Congratulations on purchasing a Full Boar Bandsaw.

Your Full Boar Bandsaw FBT-2450 has been designed for cutting wood and wood composition products. It can be used for curve cuts and straight line cutting operations like cross cutting, ripping, bevelling and compound cutting.

## SAFETY INSTRUCTIONS



**Warning!** When using mains-powered equipment, basic safety precautions, including the following, should always be followed to reduce risk of fire, electric shock, personal injury and material damage.

Read and understand the manual prior to operating this tool.

Save these instructions and other documents supplied with this tool for future reference.

## ELECTRICAL SAFETY

The electric motor has been designed for 230V and 240V only. Always check that the power supply corresponds to the voltage on the rating plate.

**Note:** The supply of 230V and 240V on Full Boar tools are interchangeable for Australia and New Zealand.

The supply cord assessed as type Y attached by using AS/NZS 60335.1. For appliances with **type Y attachment**, the instructions shall contain the substance of the following

If the supply cord is damaged, it must be replaced by an electrician or a power tool repairer in order to avoid a hazard.

### Using an Extension Lead

Always use an approved extension lead suitable for the power input of this tool. Before use, inspect the extension lead for signs of damage, wear and ageing. Replace the extension lead if damaged or defective. When using an extension lead on a reel, always unwind the lead completely. Use of an extension lead not suitable for the power input of the tool or which is damaged or defective may result in a risk of fire and electric shock.

# GENERAL SAFETY INSTRUCTIONS



**WARNING! Read all instructions.** Failure to follow all instructions listed below may result in electric shock, fire and/or serious injury. The term “Power Tool” in all of the warnings listed below refers to your mains operated (corded) power tool or battery operated (cordless) power tool.

## SAVE THESE INSTRUCTIONS

### 1. Work area safety

- a. Keep work area clean and well lit.** Cluttered or dark areas invite accidents.
- b. Do not operate power tools in explosive atmospheres, such as in the presence of flammable liquids, gases or dust.** Power tools create sparks which may ignite the dust or fumes.
- c. Keep children and bystanders away while operating a power tool.** Distractions can cause you to lose control.

### 2. Electrical safety

- a. Power tool plugs must match the outlet. Never modify the plug in any way. Do not use any adapter plugs with earthed (grounded) power tools.** Unmodified plugs and matching outlets will reduce risk of electric shock.
- b. Avoid body contact with earthed or grounded surfaces, such as pipes, radiators, ranges and refrigerators.** There is an increased risk of electric shock if your body is earthed or grounded.
- c. Do not expose power tools to rain or wet conditions.** Water entering a power tool will increase the risk of electric shock.
- d. Do not abuse the cord. Never use the cord for carrying, pulling or unplugging the power tool. Keep cord away from heat, oil, sharp edges or moving parts.** Damaged or entangled cords increase the risk of electric shock.
- e. When operating a power tool outdoors, use an extension cord suitable for outdoor use.** Use of a cord suitable for outdoor use reduces the risk of electric shock.
- f. If operating a power tool in a damp location is unavoidable, use a residual current device (RCD) protected supply.** Use of an RCD reduces the risk of electric shock.

### 3. Personal safety

- a. Stay alert, watch what you are doing and use common sense when operating a power tool. Do not use a power tool while you are tired or under the influence of drugs, alcohol or medication.** A moment of inattention while operating power tools may result in serious personal injury.
- b. Use personal protective equipment. Always wear eye protection.** Protective equipment such as dust mask, non-skid safety shoes, hard hat, or hearing protection used for appropriate conditions will reduce personal injuries.
- c. Prevent unintentional starting. Ensure the switch is in the off-position before connecting to power source and/or battery pack, picking up or carrying the tool.** Carrying power tools with your finger on the switch or energising power tools that have the switch on invites accidents.

## GENERAL SAFETY INSTRUCTIONS (cont.)

**d. Remove any adjusting key or wrench before turning the power tool on.** A wrench or a key left attached to a rotating part of the power tool may result in personal injury.

**e. Do not overreach. Keep proper footing and balance at all times.** This enables better control of the power tool in unexpected situations.

**f. Dress properly. Do not wear loose clothing or jewellery. Keep your hair, clothing and gloves away from moving parts.** Loose clothes, jewellery or long hair can be caught in moving parts.

**g. If devices are provided for the connection of dust extraction and collection facilities, ensure these are connected and properly used.** Use of dust collection can reduce dust-related hazards.

### 4. Power tool use and care

**a. Do not force the power tool. Use the correct power tool for your application.** The correct power tool will do the job better and safer at the rate for which it was designed.

**b. Do not use the power tool if the switch does not turn it on and off.** Any power tool that cannot be controlled with the switch is dangerous and must be repaired.

**c. Disconnect the plug from the power source and/or the battery pack from the power tool before making any adjustments, changing accessories, or storing power tools.** Such preventive safety measures reduce the risk of starting the power tool accidentally.

**d. Store idle power tools out of the reach of children and do not allow persons unfamiliar with the power tool or these instructions to operate the power tool.** Power tools are dangerous in the hands of untrained users.

**e. Maintain power tools. Check for misalignment or binding of moving parts, breakage of parts and any other condition that may affect the power tool's operation. If damaged, have the power tool repaired before use.** Many accidents are caused by poorly maintained power tools.

**f. Keep cutting tools sharp and clean.** Properly maintained cutting tools with sharp cutting edges are less likely to bind and are easier to control.

**g. Use the power tool, accessories and tool bits etc. in accordance with these instructions, taking into account the working conditions and the work to be performed.** Use of the power tool for operations different from those intended could result in a hazardous situation.

### 5. Service

**a. Have your power tool serviced by a qualified repair person using only identical replacement parts.** This will ensure that the safety of the power tool is maintained.

**b. If the supply cord of this power tool is damaged, it must be replaced by the manufacturer, its service agent or similarly qualified persons in order to avoid a hazard.**

## ADDITIONAL SAFETY RULES FOR BANDSAWS

**Hold power tool by insulated gripping surfaces, when performing an operation where the cutting accessory may contact hidden wiring or its own cord.** Cutting accessory contacting a “live” wire may make exposed metal parts of the power tool “live” and could give the operator an electric shock.

**This appliance is not intended for** use by persons (including children) with reduced physical, sensory or mental capabilities, or lack of experience and knowledge, unless they have been given supervision or instruction concerning use of the appliance by a person responsible for their safety.

**Children should be supervised to ensure that they don't play with the appliance.**

**Recommendations for the use of a residual current device** with a rated residual current of 30mA or less.

- Pull out all nails in the material before starting to saw. Cutting nails may damage your tool.
- Do not operate your scroll saw until it is completely assembled and installed according to the instructions and until you have read and understood all of the instructions.
- Do not touch moving parts with your fingers or hands.
- Ensure that you have tightened the blade prior to starting the machine.
- When finishing sawing, wait until the saw blade has ceased moving prior to removing it from the material.
- Do not touch the saw blade immediately after use. Allow time for the blade to cool, otherwise it could burn you due to the heat generated during sawing.
- Always check accessories to ensure that they are suitable for the operating speeds of this tool.
- Incorrect accessories can break apart at high speed and cause serious damage or personal injury.
- Never turn your scroll saw on before clearing the table of all objects (tools, scraps of wood, etc.) except for the workpiece.
- Hold the work firmly against the table.
- Do not feed the material too fast while cutting. Only feed the material fast enough so that the blade will cut.
- Never leave the scroll saw running unattended. Always turn the saw off, make sure that it has come to a complete stop, and then remove plug from the power supply before leaving the work area.
- Use caution when cutting off material which is irregular in cross section as it could pinch the blade before the cut is completed. A piece of moulding, for example, must lay flat on the table and not be permitted to rock whilst being cut.



## ADDITIONAL SAFETY RULES FOR BANDSAWS (cont.)



**WARNING!** Some dust created by sanding, sawing, grinding, drilling and other construction activities contain chemicals known to cause cancer, birth defects or other reproductive harm. Some examples of these chemicals are:

- Lead from lead-based paints;
- Crystalline silica from bricks, cement and other masonry products, and;
- Arsenic and chromium from chemically-treated timber.

The risk from such exposures vary depending on how often you do this type of work.

To reduce your exposure to these chemicals; work in a well ventilated area, and work with approved safety equipment, such as those dust masks that are specifically designed to filter out microscopic particles.

Always wear eye protection and a dust mask for dusty applications and when drilling/chiselling overhead. Sanding particles can be absorbed by your eyes and inhaled easily and may cause health complications.

**Caution: Always Wear safety goggles, ear protection and a respiratory mask.**

# ASSEMBLY

## Unpacking:

- Open carton and remove top packing material.
- Carefully lift the Bandsaw from the packaging and place it on a level work surface.
- Unpack the contents.

## Assembly of stand (15):

The legs are constructed by assembling each half of the structure and then joining them together.

1. Lay two legs (26) on the ground, parallel to each other. Place one long upper support (24) in between the legs (26) and align the bolt holes (Fig 1).

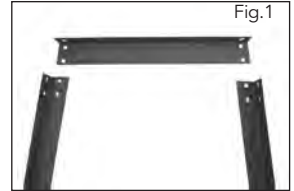

2. The long upper support (24) should have its lip on the high side (facing up). Before bolting the long upper support (24), ensure that it sits inside of the legs (26). (Fig 2).



3. Once aligned, insert the bolt (28) & Washer (30) from the outside and tighten the nut with washer (30) on the inside to attach the long upper support (24). (only hand tight at this initial stage) (Fig 3).



4. Assemble the long side support (25) halfway down the legs (26) where the bolt holes align. The long side support (25) sits inside of the legs (26) with the lip facing up (Fig.4).



5. At this stage your frame should look like this. (Fig 5).



## ASSEMBLY (cont.)

6. Assemble one of the short upper support (22) pieces, ensuring it sits inside of both the leg (26) & long upper support (24). The oval and round holes should match on each piece (Fig 6).



7. The bolts (28), nuts & Washers (30) can then be assembled as per step 1. Once the nuts (30) are hand tight, lift the frame up with only the legs (26) contacting the floor. (Fig 7). One half of the frame is now complete.



8. Repeat the exact process for the other side, which should leave you with 2 identical halves. These halves can now be joined together to complete the frame. (Fig 8)

**Note:** Nuts & Bolts should only be finger tight at this stage.



9. Align the holes of each opposing member. If the holes are misaligned and cannot be aligned by hand, use of a soft hammer to 'tap' the members together is recommended. Bolts (28) and nuts (30) can be inserted & tightened with hand force only.(Fig 9).



10. Assemble the short side support (23) halfway down the legs (26) where the bolt holes align. The short side support (23) sits inside of the legs (26) with the lip side, similarly to the short upper support (22) piece. Once all of the members are joined together and all fasteners are assembled, the provided spanners (33) can be used to tension the bolts. The rubber feet (27) can now be attached to complete the stand. (Fig 10).



11. Place the bandsaw on the stand. Bolt (29), Nut & Washer (30) can be inserted and tightened (Fig 11).



## ASSEMBLY (cont.)



**WARNING!** Prior to assembly, ensure you switch the machine off and disconnect it from the power supply.

### Small dust port (Fig.12):

1. Assemble the small dust port (7) over with the grate by first removing the 4 screws and washer from the grate and reattaching with the small dust port (7).

**Note:** The grate is a safety feature and should never be removed from the bandsaw.

### Assembling of saw table (19):

1. Remove plastic wing nut on underside of the saw table (19) (Fig 13).



2. Lead the blade (5) through the slot in the saw table (19) (Fig 14). Place the saw table (19) on the table guide so that the clamping screw fits through the mounting.

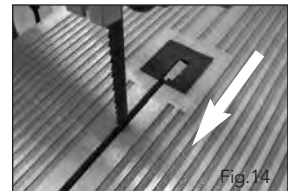

3. Screw the saw table (19) tight with the plastic wing nut (Fig 15).



4. Place the fence guide on the saw table (19) so the screw heads slide into the guide slots (Fig 16). Secure the fence guide tight with the plastic knobs on the underside of saw table (19).

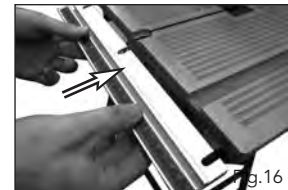

5. Manually check that the blade (5) runs freely and does not touch the saw table (19) (Fig 17).



## OPERATION

Before adjusting the tension & tracking of the blade, please ensure the upper & lower guides are well clear of the blade (following the steps below).

### Upper guide

- Loosen the guide block nut (Fig.18) to allow the entire upper blade guide (4) to move relative to the blade (5). Slide the entire block away from the blade, preparing it for adjustment.

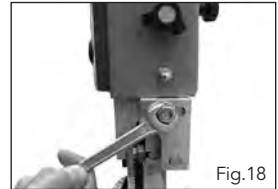

Fig.18

### Lower guide

- Loosen the guide block nut (Fig.19) to allow the entire lower blade guide (6) to move relative to the blade. Slide the entire block away from the blade, preparing it for adjustment.



Fig.19

### Tensioning blade:

- The blade (5) tension can be checked by applying pressure to the side of the blade (5) with your finger, while using a ruler to measure the distance between the blade and the housing (Fig.20). Note that this distance should be 7mm when no pressure is applied to the blade.
- Before adjusting the tracking of the blade, the blade tension measurement should be set to approx. 2mm when applying pressure (Fig.20). If the measurement is less than 2mm, turn the blade tension knob (1) clockwise to increase the tension (Fig.21). If measurement is greater than 2mm, turn the knob anti-clockwise.
- After blade tracking is complete, prepare the saw for operation by increasing the tension. Blade tension measurement for operation should be approx. 5mm.



Fig.20



Fig.21

**CAUTION! The blade (5) may break if the tension is too high. BEWARE OF INJURY!**

If the tension is too low, the powered lower wheel (8) will spin while the blade does not move.

## OPERATION (cont.)

### Adjusting the blade tracking

**CAUTION!** The blade must be properly clamped before the blade can be adjusted.

1. Undo the turn-locks (9) and open the upper and lower doors (10) (Fig.22).



2. Manually turn the upper wheel (2) slowly in a clockwise direction (Fig.23). The blade (5) should run centrally on the upper wheel (2). If it does not, the angle at which the upper wheel (2) tilts must be adjusted.



3. If the blade (5) runs more towards the rear of the upper blade pulley (2), the blade tracking knob (13) must be turned in a anticlockwise direction (Fig.24). Then turn the upper wheel (2) slowly with the other hand to check the position of the blade (5).



4. If the blade (5) runs towards the front of the upper wheel (2) the blade tracking adjustment (13) must be turned clockwise direction.
5. After adjusting the upper wheel (2), check the position of the blade (5) on the lower wheel (8). The blade (5) should run in the middle of the lower wheel (8). If it does not , the angle at which the upper wheel (2) tilts must be adjusted again.
6. The upper & lower wheels (2 & 8) must be turned several times until the adjustment of the upper wheel (2) has an effect on the position of the blade (5) on the lower wheel (8).
7. Close the Upper and lower housing doors (10), secure with the door lock (9).
8. Re-tension blade for operation.
9. Final tensioning of the blade (5) may slightly affect the tracking. Minor adjustments to the tracking can be made at operating tension.

## OPERATION (cont.)

### Adjusting the Blade Guides

Guide bearings must be adjusted before using the product for the first time and anytime the blade (5) is changed.

#### 1. Upper guide & support bearings.

- Loosen the guide block nut (Fig.25) to allow the entire upper blade guide (4) to move relative to the blade (5). Ensure blade tension & tracking are correctly set before adjusting guide & support bearings.
- Once tension & tracking have been set, slide the entire guide block forward, allowing the front edge of the guide bearings to sit 0.5mm from the front of the blade teeth (Fig.26). Once positioned, tighten the guide nut to lock into place.
- Loosen guide bearings (Fig.27) & rear support bearing retaining nut (Fig.28) with the supplied spanner (33), allowing them to slide freely.
- Move the front guide bearings to within 0.5mm, either side of the blade (Fig. 29). Once positioned they can be locked in place by tightening the nut (Fig. 27)
- Slide the rear support bearing to within 0.5mm of the rear of the blade (Fig.30).

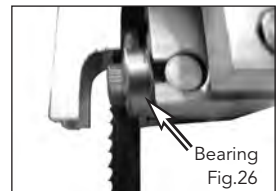
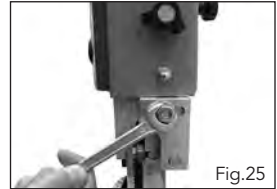

**Note:** Ensure the guide bearings are NOT touching the blade (5) when the unit is idle. The blade (5) must have some movement to ensure performance and durability.

#### 2. Lower guide & support bearing

- Remove saw table (19).
- Loosen the guide block nut (Fig.31) to allow the entire lower blade guide (6) to move relative to the blade.



## OPERATION (cont.)

- Slide the entire guide block forward, allowing the front edge of the guide bearings to sit 0.5mm from the front of the blade teeth (Fig.32). Once positioned, tighten the guide nut to lock into place.
- Loosen the guide bearing retainer nuts (Fig.33) with the supplied hex key (32) & the rear support bearing (Fig.34) with the supplied spanner (33), allowing them to slide freely.
- Move the front guide bearings to within 0.5mm, either side of the blade (Fig.33). Once positioned they can be locked in place by tightening the nut.
- Slide the rear support bearing to within 0.5mm of the rear of the blade (Fig.35).

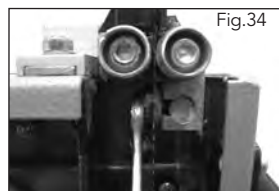

**Note:** Ensure the guide bearings are NOT touching the blade when the unit is idle. The blade must have some movement to ensure optimal performance and durability.

### Adjusting the Upper Blade Guide (4) (Fig. 36)

The upper blade guide (4) should always be set as close as practical against the workpiece.

1. While holding the upper blade guide (4), loosen the upper blade guide knob (3).
2. Lower or raise the upper blade guide (4) as close as possible to the workpiece to be cut, approx. 2-3mm.
3. Tighten upper blade guide knob (3).
4. Check the setting before each cut and re-adjust if necessary.



### Adjusting the Saw Table (19) (Fig. 37)

For bevel cuts the saw table (19) can be tilted through 45°.

1. Loosen the plastic wing nut on underside of the saw table (19).
2. Set saw table (19) to the required angle as shown by the bevel angle pointer (18).
3. Tighten the plastic wing nut at selected bevel angle.

**Note:** It is recommended to verify the correct angle setting by making trial cuts in scrap wood.





## OPERATION (cont.)

### On/Off Switch (11)

1. To turn the bandsaw on, press the green button ON (I) (Fig.38).
2. To turn the bandsaw off, press the red button OFF (O).

**Note:** In the event of a voltage failure an undervoltage relay will trip. This prevents the bandsaw from starting up when the power is restored. To restart, the green button ON (I) must be pressed.



Fig.38

### Rip Fence (20) (Fig. 39)

The rip fence (20) clamps to the front of the saw table (19), either to the left or right of the blade (5) .

1. Clamp the rip fence (20) in the desired position by pressing the clamping lever.



Fig.39

### Mitre Fence (21) (Fig. 40)

The mitre fence (21) is inserted into the saw table slot from the saw tables (19) front edge.

For mitre cuts the mitre fence (21) turns to 60° in both directions.

1. Loosen the knurled screw
2. Turn the mitre fence (31) until the arrow points to the desired angle.
3. Retighten the knurled screw.

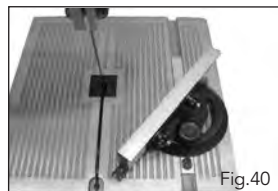

Fig.40

The auxiliary fence extrusion can be adjusted after loosening the knurled nuts.

**Note:** Do not push the auxiliary fence extrusion too far toward the blade (5), the distance should be approx. 20mm.



**WARNING!** Prior to assembly, ensure you switch the machine off and disconnect it from the power supply.

### Adjusting the cutting speed

The bandsaw can be operated at two blade speeds.

1. Open the lower housing door (10)
2. Remove the tension from the drive belt by loosening the motor mounting bolt (14) using a 6mm hex wrench (not supplied) (Fig.41).



Fig.41

## OPERATION (cont.)

3. Rotate the motor anti-clockwise (Fig.42).



4. Put the drive belt on the required pulley of the driving wheel and the corresponding motor pulley (Fig.43 & 44).

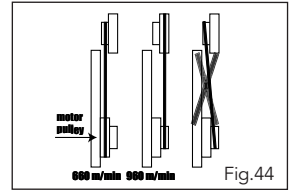

**WARNING!** The drive belt must run either on both front or both rear pulleys. Never have the belt run diagonally.

5. Tension the drive belt by returning the motor (14) to its initial position and retightening the motor mounting bolt.
6. Close the lower housing door (10).

### Push Stick (Fig. 45)

When handling narrower workpieces, it is essential to use a push stick (31). Always keep the push stick (31) close at hand at the hook provided (12).

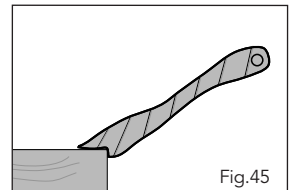

### Blade Selection

Blade supplied with the bandsaw is designed for general purpose use.

- Use a narrow blade to cut tighter radii than you can with a wider blade.
- Wide blades are used to saw straight cuts. This is particularly important in cutting wood because the blade has a tendency to follow the grain of the wood and thereby deviate easily from the cutting line.
- Finely toothed blades provided smoother cuts but are slower than coarse blades.

## OPERATION (cont.)

### Sawing

- Always guide the workpiece with both hands, holding flat on the table (19) in order to prevent the blade (5) from jamming.
- Feed the workpiece at a uniform speed that enables the blade (5) to cut through the material without difficult and without blocking.
- Always use the Rip fence (21) on all cuts for which they are intended.
- Always aim at making a complete cut in one pass rather than a stop-and-go operation requiring the workpiece to be withdrawn.
- Curve cuts which are too tight for the blade (5) to cut correctly, it can help to make a series of close-lying cuts right angles to the curve line.

**CAUTION!** When handling narrower workpieces, it is essential to use the push stick (31).

## MAINTENANCE



**WARNING!** To prevent serious injury from accidental operation:

Turn the Power Switch of the bandsaw to its "OFF" position and unplug the bandsaw from its electrical outlet before performing any inspection, maintenance, or cleaning procedures.

- Keep the ventilation vents of the tool clean at all times, if possible, prevent foreign matter from entering the vents.
- After each use, blow air through the tool housing to ensure it is free from all dust particles which may build up. Build up of dust particles may cause the tool to overheat and fail.
- If the enclosure of the tool requires cleaning do not use solvents but a moist soft cloth only. Never let any liquid get inside the tool; never immerse any part of the tool into a liquid.

**Note:** Ozito Industries will not be responsible for any damage or injuries caused by the repair of the tool by an unauthorised person or by mishandling of the tool.

## DESCRIPTION OF SYMBOLS

<b>V</b>	Volts	<b>Hz</b>	Hertz
~	Alternating current	<b>W</b>	Watts
<b>/min</b>	Revolutions or reciprocation per minute	<b>no</b>	No load speed
	Regulator compliance mark		Warning
	Read instruction manual		Wear eye, breathing, ear protection

## CARING FOR THE ENVIRONMENT



Power tools that are no longer usable should not be disposed of with household waste but in an environmentally friendly way. Please recycle where facilities exist. Check with your local council authority for recycling advice.



Recycling packaging reduces the need for landfill and raw materials. Reuse of recycled material decreases pollution in the environment. Please recycle packaging where facilities exist. Check with your local council authority for recycling advice.

## CONTENTS

1 x FBT-2450 Bandsaw	1 x Bag Bolts, Nuts & Washers
1 x Stand	2 x Hex Keys
1 x Rip Fence	2 x Spanners 10mm & 12mm
1 x Blade	1 x Slotted Screwdriver
1 x Mitre Fence	1 x Instruction manual
1 x Push Stick	
1 x Dust Extraction Outlet	

Distributed by:  
Ozito Industries Pty Ltd

**AUSTRALIA (Head Office)**

1-23 Letcon Drive, Bangholme Victoria, Australia, 3175  
Telephone: 1800 069 486

# WARRANTY

**YOUR WARRANTY FORM SHOULD BE RETAINED BY YOU AT ALL TIMES. IN ORDER TO MAKE A CLAIM UNDER THIS WARRANTY YOU MUST RETURN THE PRODUCT TO YOUR NEAREST BUNNINGS WAREHOUSE (see [www.bunnings.com.au](http://www.bunnings.com.au) or [www.bunnings.co.nz](http://www.bunnings.co.nz) for store locations) WITH YOUR BUNNINGS REGISTER RECEIPT. PRIOR TO RETURNING YOUR PRODUCT FOR WARRANTY PLEASE TELEPHONE OUR CUSTOMER SERVICE HELPLINE:**

**Australia 1800 069 486  
New Zealand 0508 069 486**

TO ENSURE A SPEEDY RESPONSE PLEASE HAVE THE MODEL NUMBER AND DATE OF PURCHASE AVAILABLE. A CUSTOMER SERVICE REPRESENTATIVE WILL TAKE YOUR CALL AND ANSWER ANY QUESTIONS YOU MAY HAVE RELATING TO THE WARRANTY POLICY OR PROCEDURE.

## **1 YEAR WARRANTY**

Your product is guaranteed for a period of **12 months from the original date of purchase**. If a product is defective it will be repaired in accordance with the terms of this warranty. Warranty excludes consumable parts, for example: wheels, bearings.

The benefits provided under this warranty are in addition to other rights and remedies which are available to you under law. The warranty covers manufacturer defects in materials, workmanship and finish under normal use.

Our goods come with guarantees that cannot be excluded under Australian Consumer law & Consumer Guarantees Act 1993 (NZ). You are entitled to a replacement or refund for a major failure and to compensation for other reasonably foreseeable loss or damage. You are also entitled to have the goods repaired and replaced if the goods fail to be of acceptable quality and the failure does not amount to a major failure.

## **WARRANTY EXCLUSIONS**

**The following actions will result in the warranty being void.**

- If the tool has been operated on a supply voltage other than that specified on the tool.
- If the tool shows signs of damage or defects caused by or resulting from abuse, accidents or alterations.
- Failure to perform maintenance as set out within the instruction manual.
- If the tool is disassembled or tampered with in any way.
- The warranty excludes damage resulting from product misuse or product neglect.

**This warranty is given by Ozito Industries Pty Ltd.**

**ABN: 17 050 731 756**

**Ph.1800 069 486**

Australia/New Zealand (Head Office)  
1-23 Letcon Drive, Bangholme, Victoria, Australia 3175