

VITE / PUMP 2
403 | 05.13

SFA



SANIVITE®

SANIPUMP2®

FR NOTICE D'INSTALLATION

UK INSTALLATION INSTRUCTIONS

DE INSTALLATIONSHINWEISE

IT STRUZIONI PER L'INSTALLAZIONE

ES MANUAL DE INSTALACIÓN

PT MANUAL DE INSTALAÇÃO

NL INSTALLATIE VOORSCHRIFTEN

SE INSTALLATIONSANVISNING

DK INSTALLATIONSVEJLEDNING

NO INSTALLASJONSANVISING

FI ASENNUSOHJEET

HU FELSZERELÉSI ÉS KEZELÉSI ÚTMUTATÓ

PL INSTRUKCJA INSTALACJI

RU ИНСТРУКЦИЯ ПО МОНТАЖУ И ЭКСПЛУАТАЦИИ

RO MANUAL DE INSTALARE

CZ NÁVOD K INSTALACI A POUŽÍVÁNÍ

TR KURULUM KILAVUZU

EL ΟΔΗΓΙΕΣ ΕΓΚΑΤΑΣΤΑΣΗΣ

CN 用户应保留安装指南以备

KR 설치내용서

CE

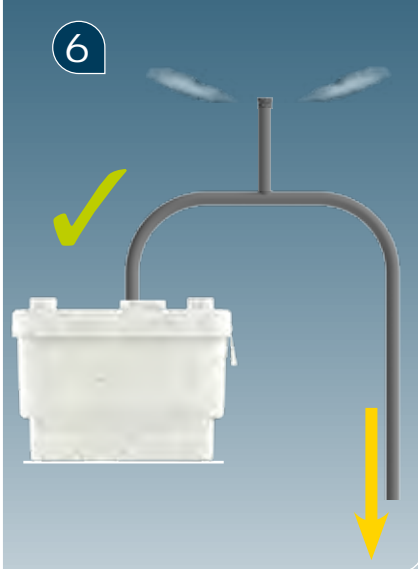
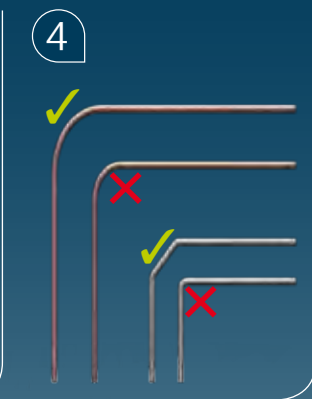
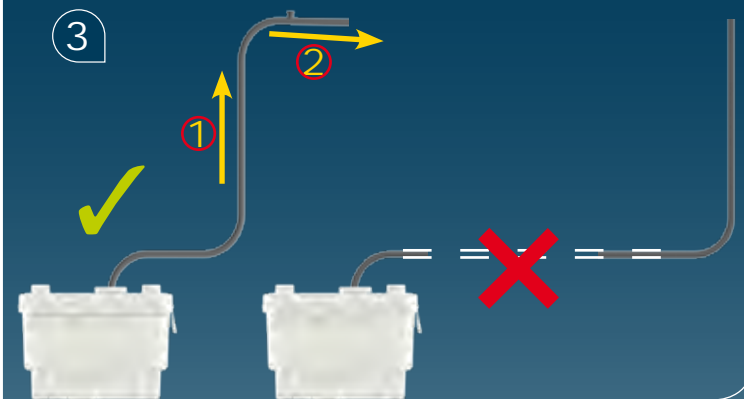
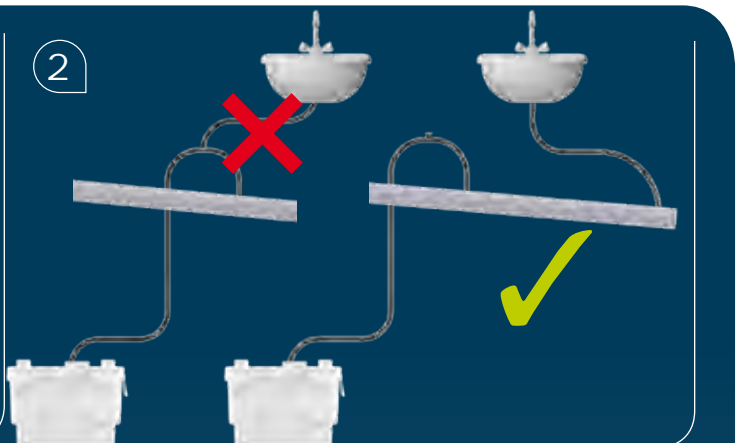
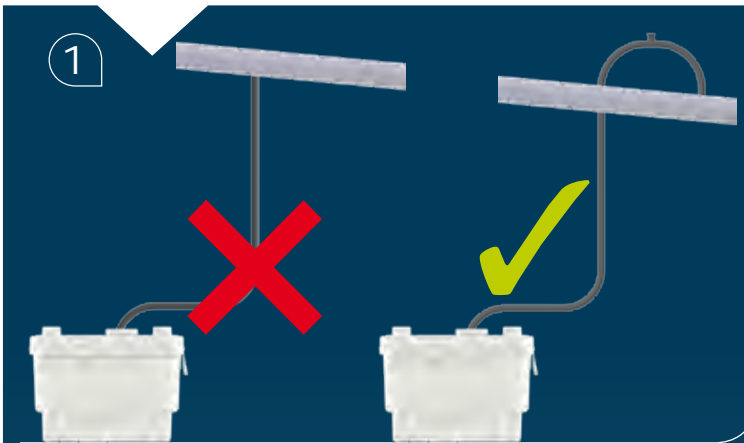

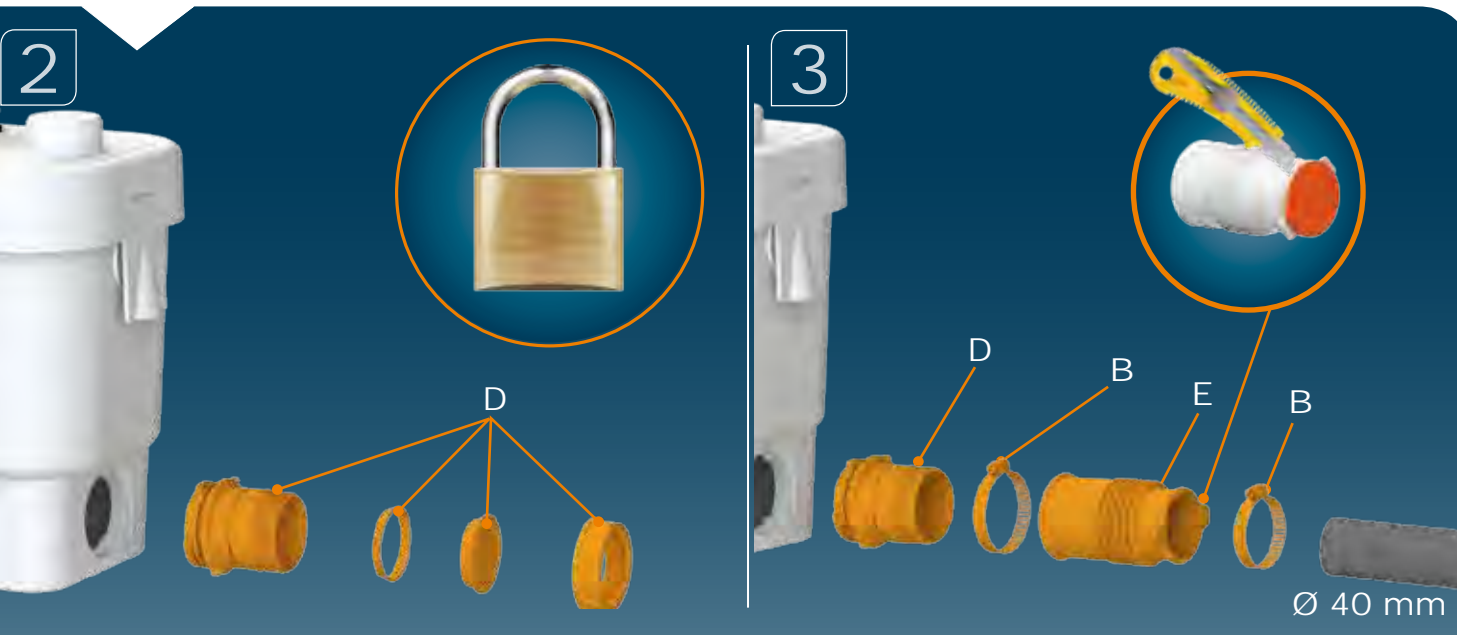
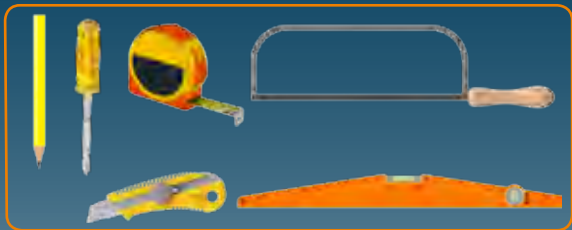
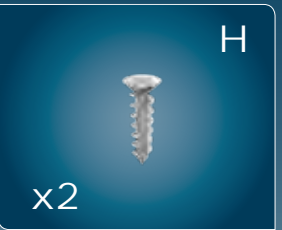
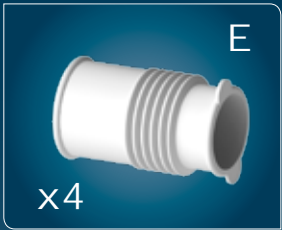

4

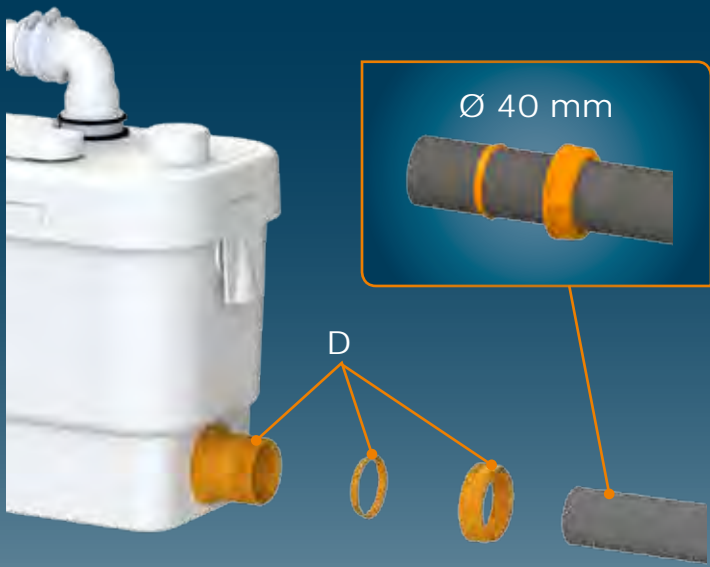

5

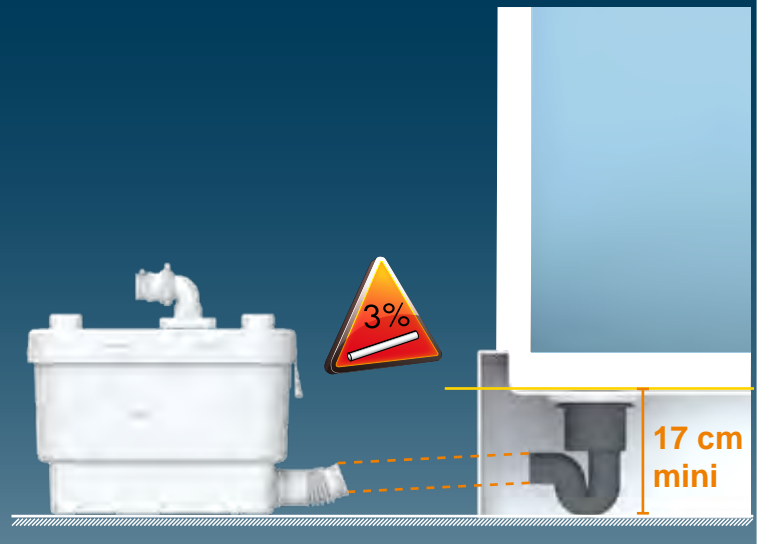

6



7

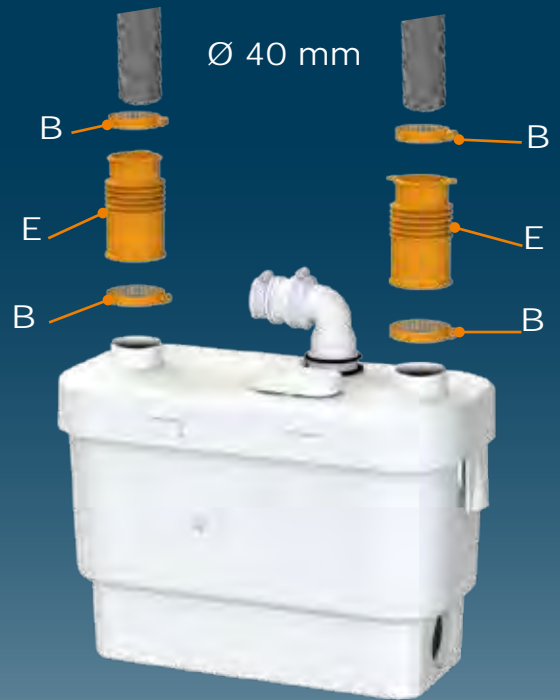

8



9



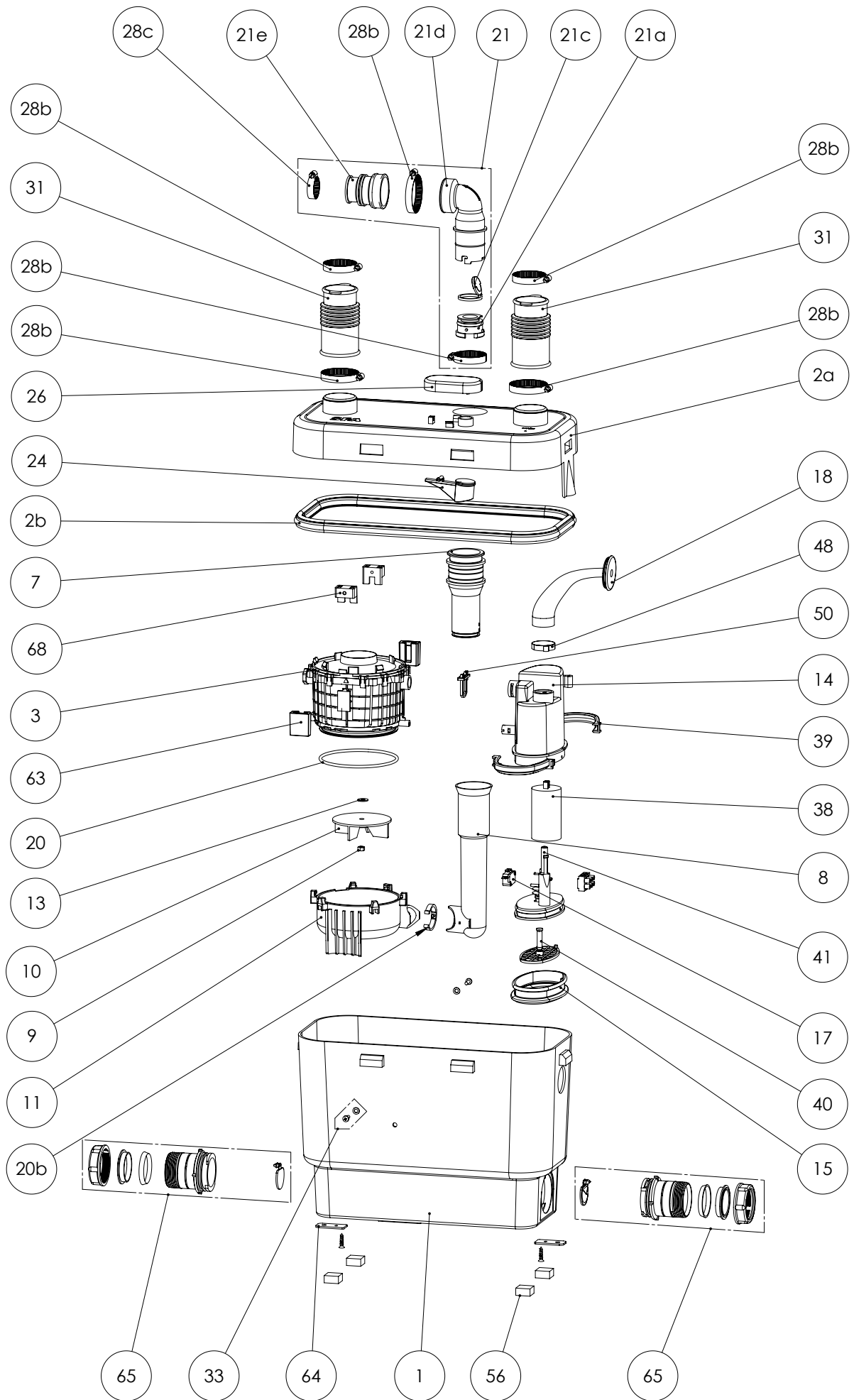

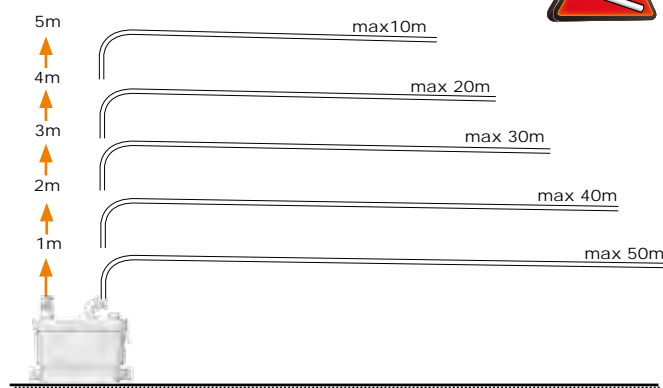
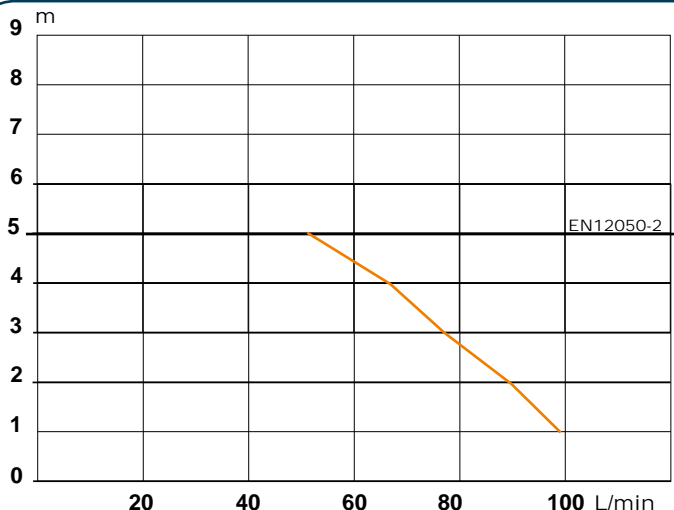

SANIVITE/SANIPUMP 2

EN 12050-2

V35

220-240 V - 50 Hz

400 W - IP44 - 1,7 A

6,4 KG

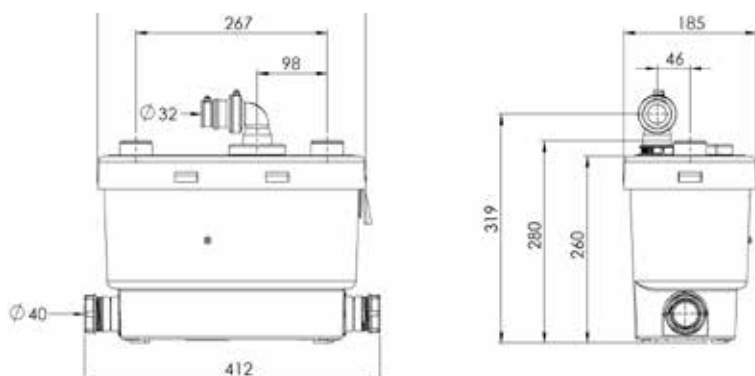

FRANCE

SOCIÉTÉ FRANÇAISE D'ASSAINISSEMENT

8, rue d'Aboukir - 75002 Paris
Tél. +33 1 44 82 39 00
Fax +33 1 44 82 39 01

UNITED KINGDOM

SANIFLO Ltd.,
Howard House, The Runway
South Ruislip Middx.,
HA4 6 SE
Tel. +44 208 842 0033/4040
Fax +44 208 842 1671

IRELAND

SANIRISH Ltd
IDA Industrial Estate
Edenderry - County Offaly
Tel. + 353 46 9733 102
Fax + 353 46 97 33 093

AUSTRALIA

SANIFLO AUSTRALIA
Unit 9/10, 25 Gibbes Street Pty Ltd
Chatswood NSW 2067
Tel. +61 298 826 200
Fax +61 298 826 950

DEUTSCHLAND

SFA SANIBROY GmbH
Waldstr. 23 Geb. B5 - 63128
Dietzenbach CH-8954
Tel. (060 74) 30928-0
Fax (060 74) 30928-90

ITALIA

SFA ITALIA spa
Via del Benessere, 9
27010 Sizzano (PV)
Tel. 03 82 61 81
Fax 03 82 61 8200

ESPAÑA

GRUPO SFA
C/ Vinyalets, 1 - Pl. Can Vinyalets
08130 Sta. - Perpètua de Mogoda -
Barcelona
Tel. +34 93 544 60 76
Fax +34 93 462 18 96

PORTUGAL

SFA, Lda.
Sintra Business Park, ed.01-1ºP
2710-089 SINTRA
Tel. +351 219 112 785
Fax +351 219 577 000

РОССИЯ

SFA РОССИЯ
101000 Москва - Колпачный пер.9а,
Тел. (495) 258 29 51
факс: (495) 258 29 51

SUISSE SCHWEIZ SVIZZERA

SFA SANIBROY AG
Steinhaldenstrasse 28
Geroldswil CH-8954
Tel. +41 44 748 17 44
Fax +41 44 748 17 43

BENELUX

SFA BENELUX B.V.
Voltaweg 4
6101 XK Echt
Tel. +31 475 487100
Fax +31 475 486515

SVERIGE

SANIFLO AB
BOX 797
S-191 27 Sollentuna
Tel. +08-404 15 30
Fax + 08-404 15 39

POLSKA

SFA POLAND
ul. Kolejowa 33
05-092 Łomianki/Warszawa
Tel. (+4822) 732 00 32
Fax (+4822) 751 35 16

ČESKÁ REPUBLIKA

SFA-SANIBROY, spol. s r.o.
Na Košince - 180 00 PRAHA 8 - Libeň
Tel. +420 266 712 855
Fax, +420 266 712 856

ROMANIA

SFA SANIFLO S.R.L.
Strada Leonard Nicolae, nr. 2A
Timișoara 300454
Tel. +40 256 245 092
Fax +40 256 245 029

TÜRKIYE

SFA SANIHYDRO LTD STI
Ortaklar Caddesi No:7 Ünal Apt. D: 2
34394 MECIDIYEKÖY - İSTANBUL
Tel. +90 212 275 30 88
Fax, +90 212 275 90 58

CHINA

SFA 中国
上海市静安区石门二路333弄3号振安
广场恒安大厦27C室 (200041)
T: +86(0)21 6218 8969
F: +86(0)21 6218 8970

KOREA

www.SFA.biz
sales@saniflo-korea.kr

SERVICE HELPLINES

	TEL	FAX		TEL	FAX
France	08 810 05 90 02	03 44 94 46 19	Benelux	+31 475 487100	+31 475 486515
United Kingdom	08457 650011 (Call from a land line)	020 8842 1671	Sverige	08-744 15 18	08-404 15 39
Ireland	1850 23 24 25 (LOW CALL)	+ 353 46 97 33 093	Norge	+47 951 61 131	
Australia	+61 298 826 200	+61 298 826 950	Polyska	(+4822) 732 00 33	(+4822) 751 35 16
Deutschland	0800 82 27 82 0	(060 74) 30928-90	Россия	(495) 258 29 51	(495) 258 29 51
Italia	0382 6181	+39 0382 618200	Česká Republika	+420 266 712 855	+420 266 712 856
España	+34 93 544 60 76	+34 93 462 18 96	România	+40 256 245 092	+40 256 245 029
Portugal	+351 219 112 785	+351 219 577 000	Türkiye	+90 212 275 30 88	+90 212 275 90 58
Suisse Schweiz Svizzera	+41 44 748 17 44	+41 44 748 17 43	中国	+86(0)21 6218 8969	+86(0)21 6218 8970

Service information : www.sfa.biz

1 DESCRIPTION

This lifting station is (manufactured in a factory which is quality) certified to ISO 9001. Installed and used correctly, the unit will give consistent and reliable service.

This device is not designed for persons (including children) with limited physical, sensory or mental abilities, or those with minimal experience and knowledge, unless they are monitored and are given the necessary instructions for using the device, with the help of a person responsible for their safety. Monitor children and make sure they do not play with the device.

2 APPLICATIONS

This device is a compact lifting station designed to evacuate waste water from private dwellings (except for water coming from WC's).

SANIVITE®, SANISPEED® and SANIPUMP 2® are designed to handle the waste evacuation from a bath domestic kitchen sink, dishwasher and washing machine - all working at the same time if required. Its powerful pump will deal with every day normal usage. SANISHOWER® FLAT/ SANIDOUCHE® FLAT is designed to handle the waste from a shower only.

Sanispeed will take the above at a heavier duty rate of usage.

SANISHOWER®/SANIPUMP 1® is designed to take the waste from a shower and handbasin.

This appliance conforms to EN 12050-3 and the European standards concerning electrical safety and electromagnetic compatibility.

3 INSTALLATION

The unit should be installed in the same space as the connected facilities and should be accessible for possible service. The fitting and working of your appliance must meet local regulations and the EN 12056-4 standard.

To optimise the latest technical developments concerning soundproofing incorporated into this unit, it is important to:

- fix the discharge pipe correctly, with distances of not more than one metre between the fastenings.

CONNECTION TO THE ELECTRICAL SUPPLY

The electrical installation should be carried out by a qualified person.

The unit should be connected to a fully earthed electrical supply. All wiring must conform to BS7671, 1992 requirements for electrical installations. The unit requires a 220/240V single phase AC 50 Hz supply (UK specification). Do not connect the unit to a conventional plug and socket. **It must be wired into a fused, unswitched, fixed wiring connector fitted with a 5 amp fuse.** The wires in the mains lead are coloured in accordance with the following code:

Brown - Live
Blue - Neutral
Green/Yellow - Earth

Warning: Ensure the electricity is turned OFF at the main switch board before wiring to connector.

All work on cable, pressure chamber and motor should only be carried out

by a qualified Saniflo servicing agent, as special tools are required.

4 COMMISSIONING THE UNIT

Once electrical and plumbing connections have been made, check that all seals, and connections are watertight.

Check both the discharge pipework from the unit and the other sanitary appliances connections.

5 MAINTENANCE WARNING !!!

If away for a long period, we recommend that you turn off the water supply to the WC served by the unit.

CARE OF YOUR UNIT

In order to remove scale and clean the lifting station, use a household descaler (like SANIFLO Cleanser/descaler).

6 FAULT FINDING / REMEDIES

IN ALL CASES, YOU MUST DISCONNECT THE MACERATOR FROM THE POWER SUPPLY

SYMPTOMS	PROBABLE CAUSES	REMEDIES
<ul style="list-style-type: none"> • The motor does not activate 	<ul style="list-style-type: none"> • The electrical power supply is not active • The electrical power supply is defective • The motor or the control system is defective 	<ul style="list-style-type: none"> • Restore the electrical supply • Check the electrical power supply • Otherwise, ask an approved repair agent to intervene
<ul style="list-style-type: none"> • The motor intermittently activates 	<ul style="list-style-type: none"> • The connected sanitary devices are leaking • The non-return valve is faulty 	<ul style="list-style-type: none"> • Check the installation upstream • Clean or replace the non-return valve • Check the installation
<ul style="list-style-type: none"> • The motor operates normally, but continues to run for a long time 	<ul style="list-style-type: none"> • The length or height of the installation is over the specification, or there are too many bends/elbows • The lifting station cover plate is occluded 	<ul style="list-style-type: none"> • Otherwise, ask an approved repair agent to intervene
<ul style="list-style-type: none"> • The unit stops 	<ul style="list-style-type: none"> • The unit has been running for too long (thermal cut-out) 	<ul style="list-style-type: none"> • Wait for reset, then ask an approved repair agent to intervene • Check the installation
<ul style="list-style-type: none"> • Cloudy water comes up into the shower basin (units with side inlets) 	<ul style="list-style-type: none"> • Shower installed too low as compared with the lifting station • Hinged side inlet discs clogged up 	<ul style="list-style-type: none"> • Clean the hinged discs • Otherwise, ask an approved repair agent to intervene

7 GUARANTEE

2 years guarantee as from its date of purchase subject to correct installation and correct use.

Warning : Do not dispose of solvents, paints (do not wash paint brushes in sink), caustic, acid or other chemicals into these products.

FRANCE**SOCIÉTÉ FRANÇAISE
D'ASSAINISSEMENT**

8, rue d'Aboukir - 75002 Paris
Tél. + 33 1 44 82 39 00
Fax + 33 1 44 82 39 01

UNITED KINGDOM**SANIFLO Ltd.,**

Howard House, The Runway
South Ruislip Middx.,
HA4 6SE
Tel. +44 208 842 0033/4040
Fax +44 208 842 1671

IRELAND**SANIRISH Ltd**

IDA Industrial Estate
Edenderry - County Offaly
Tel. + 353 46 9733 102
Fax + 353 46 97 33 093

AUSTRALIA**SANIFLO (Australasia) Pty Ltd**

Unit 9-10, 25 Gibbs Street
Chatswood
NSW 2067
Tel. +61 298 826 200
Fax +61 298 826 950

DEUTSCHLAND**SFA SANIBROY GmbH**

Waldstr. 23 Geb. B5 - 63128 Dietzenbach
Tel. (060 74) 30928-0
Fax (060 74) 30928-90

ITALIA**SFA ITALIA spa**

Via del Benessere, 9
27010 Sizzano (PV)
Tel. 03 82 61 81
Fax 03 82 61 8200

ESPAÑA**SFA SI**

C/ Vinyalets,1 - P.I. Can Vinyalets
08130 Santa Perpètua de Mogoda
Barcelona
Tel. +34 93 544 60 76
Fax +34 93 462 18 96

PORTUGAL**SFA, Lda.**

Sintra Business Park, ed. 01-1*P2710-089
SINTRA
Tel. +35 21 911 27 85
Fax. +35 21 957 70 00

SUISSE SCHWEIZ SVIZZERA**SFA SANIBROY AG**

Steinhaldenstrasse 28
CH - 8954 Geroldswil
Tel. : +41 44 748 17 44
Fax: +41 44 748 17 43

BENELUX**SFA BENELUX B.V.**

Voltaweg 4
6101 XK Echt (NL)
Tel. +31 475 487100
Fax +31 475 486515

SVERIGE**SANIFLO AB**

BOX 797
S-191 27 Sollentuna
Tel. +08-404 15 30
Fax + 08-404 15 39

POLSKA**SFA POLAND**

ul. Kolejowa 33
05-092 Łomianki/Warszawa
Tel. (+4822) 732 00 32
Fax (+4822) 751 35 16

РОССИЯ**SFA РОССИЯ**

101000 Москва - Колпачный пер.
9а, ком. 103
Тел. (495) 258 29 51
факс (495) 258 29 51

ČESKÁ REPUBLIKA**SFA-SANIBROY, spol. s r.o**

Na Košince - 180 00 PRAHA 8 - Libeň
Tel. : +420 266 712 855
Fax : +420 266 712 856

ROMANIA**SFA SANIFLO S.R.L.**

Strada Leonard Nicolae, nr. 2A
Timișoara 300454
Tel. +40 256 245 092
Fax +40 256 245 029

TÜRKIYE**SFA SANIHYDRO LTD ŞTİ**

Ortaklar Caddesi No:7 Ünal Apt. D:2
34394 MECIDIYEKÖY - İSTANBUL
Tel. : +90 212 275 30 88
Fax : +90 212 275 90 58

CHINA**SFA 中国**

上海市静安区石门二路333弄3号振安广场恒安大厦27C室 (200041)
Tel. +86(0)21 6218 8969
Fax +86(0)21 6218 8970

KOREA

www.sfa-korea.com
sales@saniflo-korea.kr

SERVICE HELPLINES

France

United Kingdom

Ireland

Australia

Deutschland

Italia

España

Portugal

Suisse Schweiz Svizzera

Benelux

Sverige

Norge

Polska

Россия

Česká Republika

România

Türkiye

中国

TEL

☎ **N°Azur 0 810 05 90 02** 1 UT par appel

08457 650011 (Call from a land line)

1850 23 24 25 (LOW CALL)

+61 3 9543 3891

0800 82 27 82 0

0382 6181

+34 93 544 60 76

+35 21 911 27 85

+41 44 748 17 44

+31 475 487100

08-404 15 30

(+47) 951 61 131

(+4822) 732 00 33

(495) 258 29 51

+420 266 712 855

+40 256 245 092

+90 212 275 30 88

+86(0)21 6218 8969

FAX

03 44 94 46 19

020 8842 1671

+ 353 46 97 33 093

+61 3 9543 6851

(060 74) 30928-90

+39 0382 618200

+34 93 462 18 96

+35 21 957 70 00

+41 44 748 17 43

+31 475 486515

08-404 15 39

(+4822) 751 35 16

(495) 258 29 51

+420 266 712 856

+40 256 245 029

+90 212 275 90 58

+86(0)21 6218 8970

Service information : www.sfa.biz