

ozito

BENCH GRINDER & BELT SANDER

150mm / 686x50mm

INSTRUCTION MANUAL

SPECIFICATIONS

Voltage:	230 - 240V ~ 50Hz
Input Power:	240W S2:30min
No Load Speed:	2,950 min ⁻¹
Grinding Wheel:	Ø150 x 20 x Ø12.7mm
Max. Speed:	23 m/s
Belt Speed:	900 m/min
Sanding Belt:	686 x 50 mm
Weight:	7.2 kg

ozito.com.au

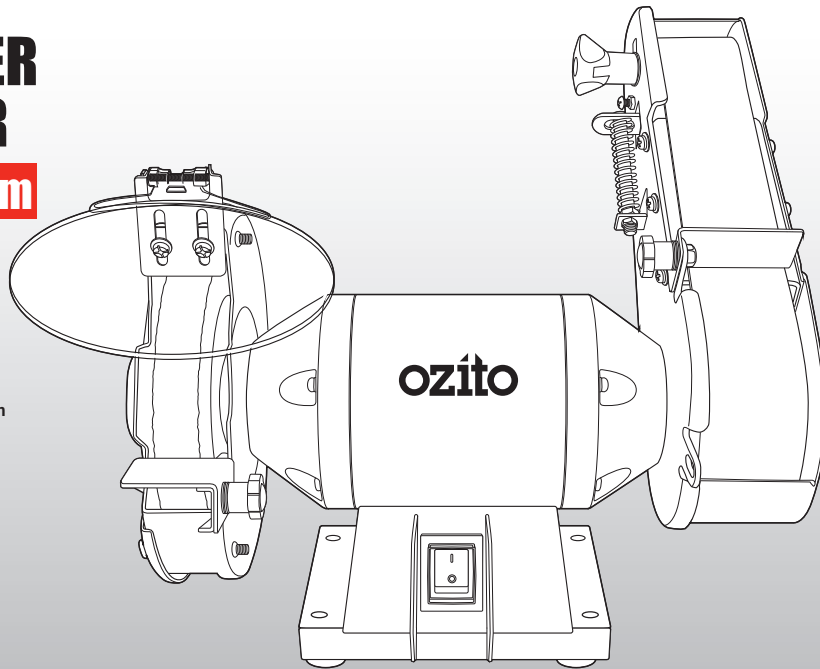

WHAT'S IN THE BOX

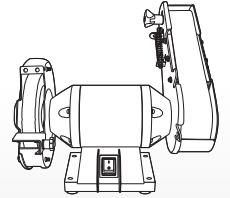

Bench Grinder & Belt Sander

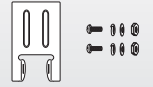

Safety Shield Bracket Assembly

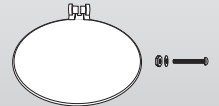

Safety Eye Shield Assembly



Tool Rest Assemblies x 2

3 YEAR REPLACEMENT WARRANTY

BGBS-240

WARRANTY

IN ORDER TO MAKE A CLAIM UNDER THIS WARRANTY YOU MUST RETURN THE PRODUCT TO YOUR NEAREST BUNNINGS WAREHOUSE WITH YOUR BUNNINGS REGISTER RECEIPT. PRIOR TO RETURNING YOUR PRODUCT FOR WARRANTY PLEASE TELEPHONE OUR CUSTOMER SERVICE HELPLINE:

Australia 1800 069 486

New Zealand 0508 069 486

TO ENSURE A SPEEDY RESPONSE PLEASE HAVE THE MODEL NUMBER AND DATE OF PURCHASE AVAILABLE. A CUSTOMER SERVICE REPRESENTATIVE WILL TAKE YOUR CALL AND ANSWER ANY QUESTIONS YOU MAY HAVE RELATING TO THE WARRANTY POLICY OR PROCEDURE.

The benefits provided under this warranty are in addition to other rights and remedies which are available to you at law.

Our goods come with guarantees that cannot be excluded at law. You are entitled to a replacement or refund for a major failure and for compensation for any other reasonably foreseeable loss or damage. You are also entitled to have the goods repaired or replaced if the goods fail to be of acceptable quality and the failure does not amount to a major failure.

Generally you will be responsible for all costs associated with a claim under this warranty, however, where you have suffered any additional direct loss as a result of a defective product you may be able to claim such expenses by contacting our customer service helpline above.

3 YEAR REPLACEMENT WARRANTY

Your product is guaranteed for a period of **36 months from the original date of purchase**. If a product is defective it will be replaced in accordance with the terms of this warranty. Warranty excludes consumable parts, for example: grinding wheels, sanding belts, etc.

WARNING

The following actions will result in the warranty being void.

- If the tool has been operated on a supply voltage other than that specified on the tool.
- If the tool shows signs of damage or defects caused by or resulting from abuse, accidents or alterations.
- Failure to perform maintenance as set out within the instruction manual.
- If the tool is disassembled or tampered with in any way.
- Professional, industrial or high frequency use.

KNOW YOUR PRODUCT

BENCH GRINDER & BELT SANDER

- | | |
|--|---|
| 1. Safety Eye Shield | 10. Grinding Wheel |
| 2. Safety Shield Adjusting Screw | 11. Tool Rest Adjustment Knob (bench grinder) |
| 3. Safety Shield Bracket | 12. Foot |
| 4. Wheel Guard Cover | 13. ON/OFF Switch |
| 5. Tool Rest Adjustment Knob (belt sander) | 14. Mounting Holes |
| 6. Tool Rest (belt sander) | 15. Belt Tension/Tracking Adjustment Knob |
| 7. Sanding Belt | 16. Belt Limit Adjustment Screw |
| 8. Side Cover Fastening Screw | |
| 9. Tool Rest (bench grinder) | |

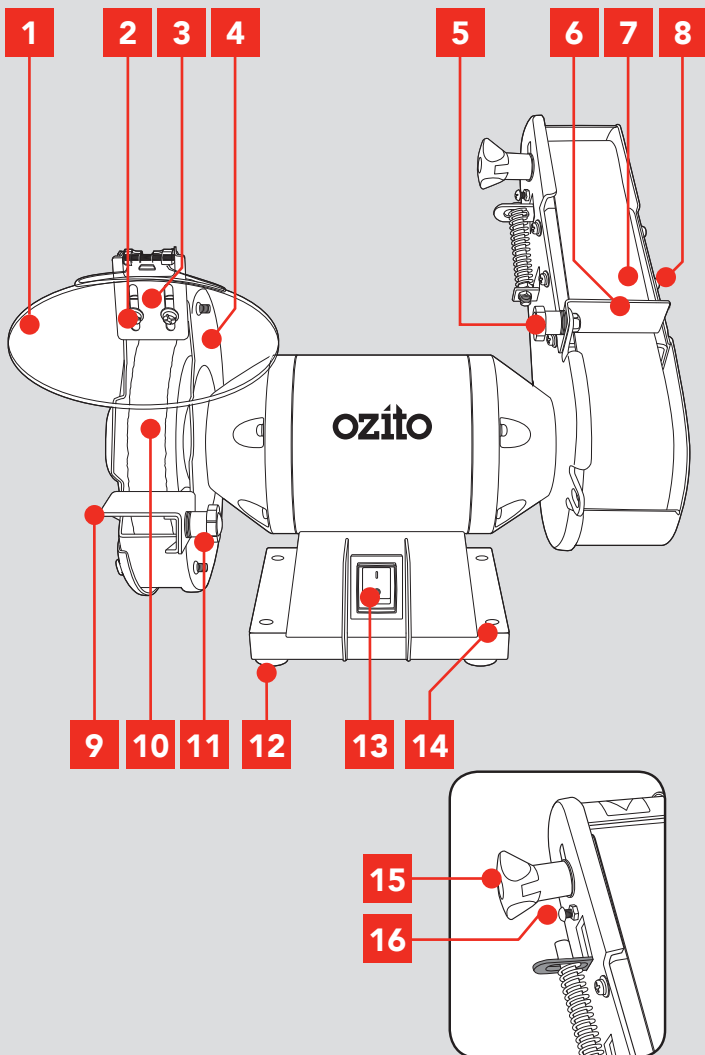

ONLINE MANUAL

Scan this QR Code with your mobile device to take you to the online manual.



SETUP & PREPARATION

1. ASSEMBLY

The Bench Grinder & Belt Sander is a combination device for the coarse and fine grinding/sanding of metals, woods of all kinds and other materials using the appropriate grinding wheel or belt.

IMPORTANT! THE EQUIPMENT AND PACKAGING MATERIAL ARE NOT TOYS. DO NOT LET CHILDREN PLAY WITH PLASTIC BAGS, FOILS OR SMALL PARTS. THERE IS A DANGER OF SWALLOWING OR SUFFOCATING!

WARNING! ENSURE THE BENCH GRINDER & BELT SANDER IS DISCONNECTED FROM THE POWER SUPPLY BEFORE PERFORMING ANY OF THE FOLLOWING OPERATIONS.

WARNING! THE BENCH GRINDER & BELT SANDER MUST BE FIXED TO A SECURE BASE IN USE.

Securing the Grinder/Sander

Before operating the Bench Grinder & Belt Sander, it must be firmly secured to a workbench, or solid surface.

Insert screws or bolts (not included) through the four mounting holes on the base and secure the grinder/sander to the solid surface.

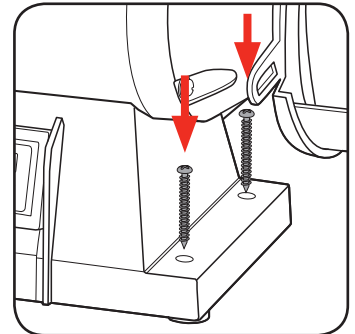

3 YEAR REPLACEMENT WARRANTY

Fitting the Safety Shield Bracket



WARNING! ALL COVERS AND SAFETY DEVICES HAVE TO BE PROPERLY FITTED BEFORE THE BENCH GRINDER & BELT SANDER IS SWITCHED ON

1. Position the safety shield bracket in front of the wheel guard cover, aligning the slots on the safety shield bracket with the holes of the wheel guard cover.

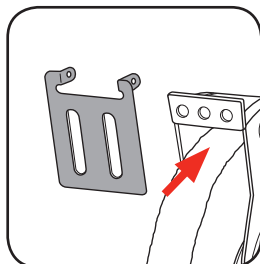

2. Attach the safety shield bracket to the wheel guard cover by screwing the safety shield adjusting screws with the spring washers and the washers, to the nuts.

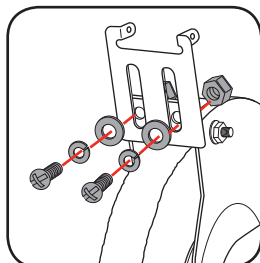

3. Position the safety shield bracket so that the distance between the grinding wheel and the safety shield bracket is as small as possible and does not exceed 2 mm.

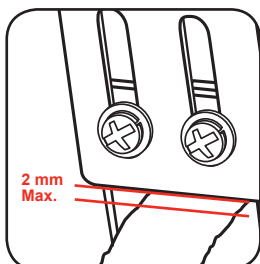

4. Hold the nuts at the rear of the safety shield bracket in place with a spanner (not supplied), while tightening the front adjusting screw with a screwdriver (not supplied).

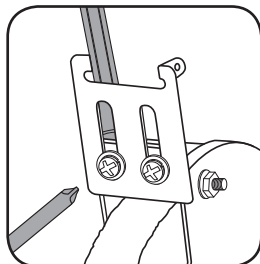

NOTE: Adjust the safety shield bracket periodically to compensate for wear on the wheel.

Fitting the Safety Eye Shield

1. Position the safety eye shield between the vertical braces at the top of the safety shield bracket.

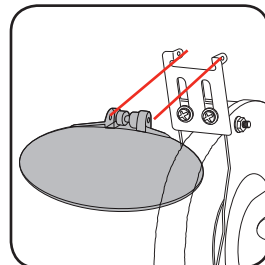

2. Insert a long screw through a washer, then through the bracket and safety eye shield (screws and washers supplied).

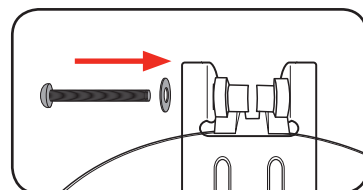

3. Fasten the assembly in place with a nut (supplied).

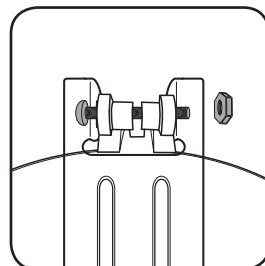

4. Hold the nut in place with a spanner (not supplied), while tightening the screw with a screwdriver (not supplied). Do not overtighten.

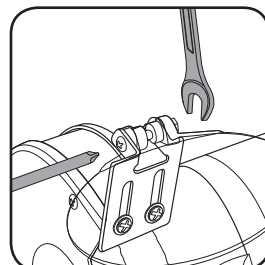

2. FITTING THE TOOL RESTS

The Bench Grinder & Belt Sander comes with two tool rest that aid the user in holding items steady as they are being applied to the grinding wheel and sanding belt.

Fitting the Grinding Wheel Tool Rest

1. Push the screw through the recess in the wheel guard cover.

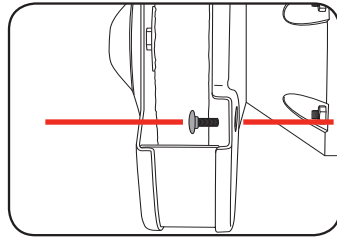

2. Mount the tool rest, then the supplied washer and toothed washer.

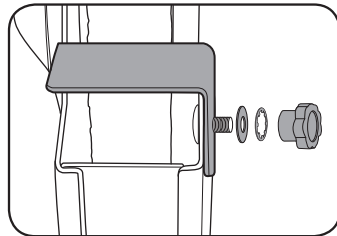

3. Secure the tool rest to the wheel guard cover using the tool rest adjustment knob. Do not fully tighten until the final adjustments have been made.

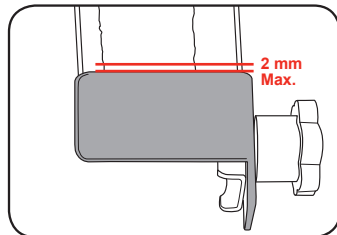

4. Adjust the tool rest so that the distance between the grinding wheel and the tool rest is as small as possible and does not exceed 2 mm.

5. Tighten the tool rest adjustment knob.

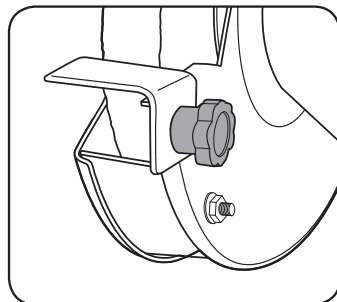

NOTE: Adjust the tool rest periodically to compensate for wear on the grinding wheel.

Fitting the Sanding Belt Tool Rest

1. Push the supplied bolt through the recess in the belt guard where you want to fasten the tool rest.

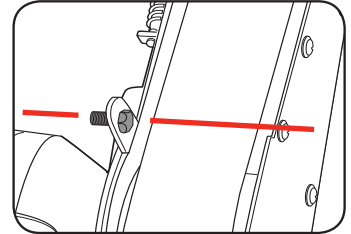

2. Place the tool rest onto the bolt, then the supplied washer and toothed washer.

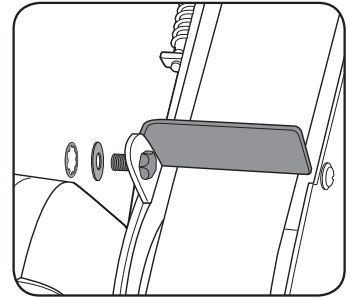

3. Secure the tool rest in place using the tool rest adjustment knob. Do not fully tighten until the final adjustments have been made.

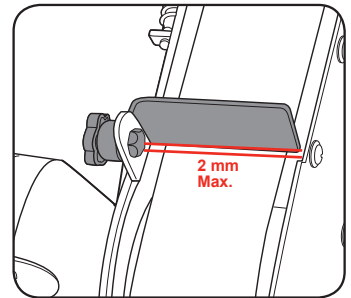

4. Adjust the tool rest so that the distance between the sanding belt and the tool rest is as small as possible and does not exceed 2 mm. Tighten the tool rest adjustment knob.

OPERATION

3. OPERATION

On/Off Switch

To reduce the risk of electrical shock, the use of a residual current device (rated 30mA or less) is recommended.

1. To switch ON the equipment set the On/Off switch to the "I" position.
2. After switching ON, wait for the equipment to reach its maximum speed of rotation. Only then should you begin with the grinding/sanding.
3. Move the On/Off switch to the "O" position to switch OFF the equipment.

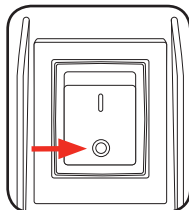
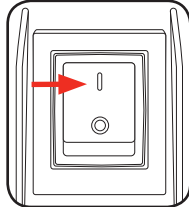

Grinding Wheel

1. Place the workpiece onto the tool rest.

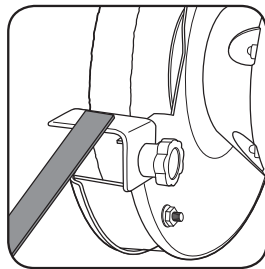

2. Slowly guide the workpiece towards the grinding wheel, ensuring that the workpiece is at the desired angle when it makes contact.

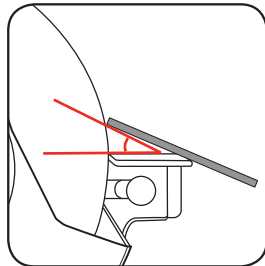

NOTE: Exert only moderate pressure on the workpiece so that it can be machined at constant speed. Instead of accelerating your work, high pressure will cause the drive unit to slow down and even stop, thus overloading the motor.

3. Move the workpiece slightly back and forth to produce an optimal grinding result. This way the grinding wheel will be evenly worn. Allow the workpiece to cool down occasionally.

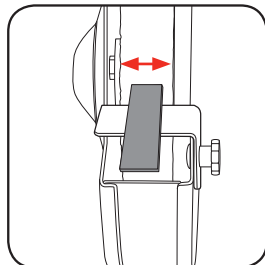

IMPORTANT! IF THE GRINDING WHEEL BECOMES JAMMED DURING OPERATION, REMOVE THE WORKPIECE AND WAIT UNTIL THE TOOL REACHES ITS TOP SPEED AGAIN.

IMPORTANT! FOR YOUR OWN SAFETY, IT IS ESSENTIAL TO SECURE SMALL WORKPIECES WITH A SCREW CLAMP OR VISE.

Belt Sander

NOTE: It may be necessary to use the Belt Tension/Tracking Adjustment Knob to ensure the sanding belt tracks in the centre of the top and bottom rollers.

1. Always hold the workpiece firmly while using the sanding belt. Do not exert excessive pressure.
2. The workpiece should be moved to and fro on the belt as you grind or sand it to prevent the paper wearing on one side.

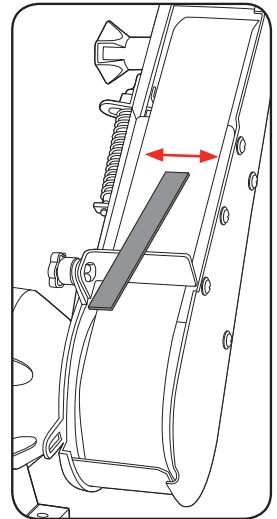

NOTE: Exert only moderate pressure on the workpiece so that it can be machined at constant speed. Instead of accelerating your work, high pressure will cause the drive unit to slow down and even stop, thus overloading the motor.

IMPORTANT! PIECES OF WOOD SHOULD ALWAYS BE SANDED WITH THE GRAIN TO PREVENT THEM SPLITTING.

MAINTENANCE

4. MAINTENANCE



WARNING! ENSURE THE BENCH GRINDER & BELT SANDER IS DISCONNECTED FROM THE POWER SUPPLY BEFORE PERFORMING ANY OF THE FOLLOWING OPERATIONS.

Changing the Sanding Belt

1. Loosen the 3 screws that hold the side section of the belt guard and remove the cover.

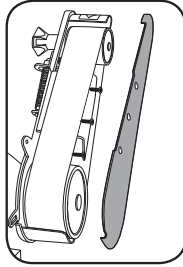

2. Release the tension on the belt by rotating Belt Tension/Tracking Adjustment Knob by a few turns.

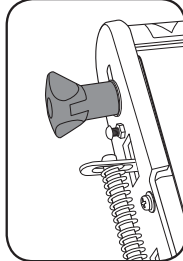

3. Pull the sanding belt off the rollers

4. Place the new sanding belt (686mm x 50mm) in the centre of the top and bottom rollers.

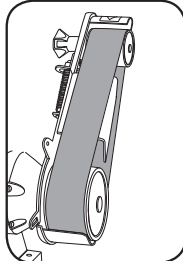

5. Now tighten the Belt Tension/Tracking Adjustment Knob and fit the side safety cover.

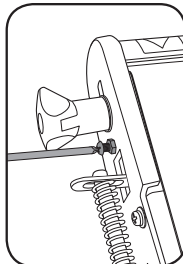

6. If required you can adjust the belt tracking with the Belt Limit Adjustment Screw and adjusting the precision of the belt run with a screwdriver (not supplied).

NOTE: Precise adjustment of the belt run is best done by turning the sanding belt by hand.

7. Once you have adjusted the belt tracking, retighten the nut with a spanner (not supplied).

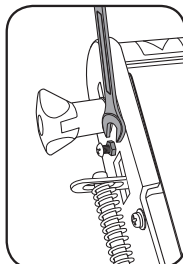

Changing the Grinding Wheel

1. Remove the 3 screws that hold the side section of the wheel guard and remove the cover.

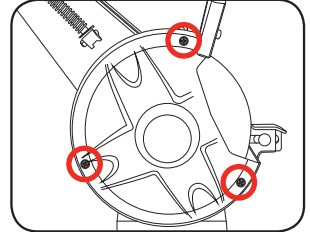

2. Loosen the 3 screws that hold the side section of the belt guard and remove the cover.

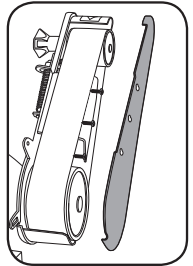

3. With a 19mm socket (not supplied), hold the sanding belt roller nut on the opposite side in position, while loosening the grinding wheel nut clockwise with a 19mm spanner or socket (not supplied).

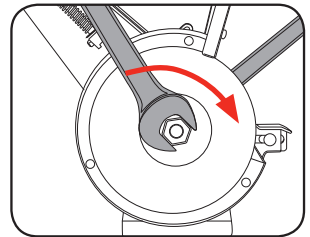

NOTE: The grinding wheel is fastened with a left handed thread.

4. Remove the wheel nut and flange from the grinding wheel and replace the grinding wheel.

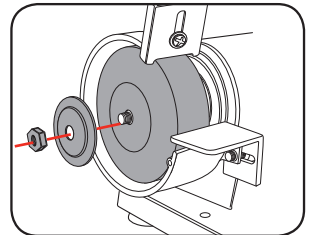

5. To assemble, proceed in the reverse order.

6. Manually spin the newly mounted wheel to check that it rotates freely prior to operation.

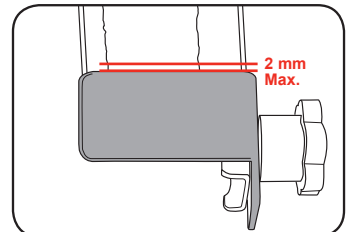

7. Adjust the tool rest so that the distance between the grinding wheel and the tool rest is as small as possible and does not exceed 2mm. Tighten the tool rest adjustment knob.

5. GENERAL MAINTENANCE

Replacing the power cable

If the power cable for this equipment is damaged, it must be replaced by the manufacturer or its after-sales service or similarly trained personnel to avoid danger.

Cleaning







- Keep all safety devices and the motor housing free of dirt and dust as far as possible. Wipe the equipment with a clean cloth or blow it with compressed air at low pressure.
- We recommend that you clean the device immediately each time you have finished using it.
- Clean the equipment regularly with a moist cloth and some soft soap. Do not use cleaning agents or solvents; these could attack the plastic parts of the equipment. Ensure that no water can seep into the device. The ingress of water into an electric tool increases the risk of an electric shock.

Storage

Store the equipment and accessories out of children's reach in a dark and dry place at above freezing temperature. The ideal storage temperature is between 5 and 30 °C. Store the electric tool in its original packaging.

NOTE: Ozito Industries will not be responsible for any damage or injuries caused by the repair of the Bench Grinder & Belt Sander by an unauthorised person or by mishandling of the Bench Grinder & Belt Sander.

DESCRIPTION OF SYMBOLS

V	Volts	Hz	Hertz
~	Alternating current	W	Watts
min⁻¹	Revolutions or reciprocation per minute	n_o	No load speed
m/s	Meters per second	∅	Diameter
	Regulator compliance mark		Wear gloves
	Read instruction manual		Wear eye protection
	Wear ear protection		Warning

CARING FOR THE ENVIRONMENT

 Power tools that are no longer usable should not be disposed of with household waste but in an environmentally friendly way. Please recycle where facilities exist. Check with your local council authority for recycling advice.

 Recycling packaging reduces the need for landfill and raw materials. Reuse of recycled material decreases pollution in the environment. Please recycle packaging where facilities exist. Check with your local council authority for recycling advice.

SPARE PARTS

Grinding Wheel Fine	4412512
Grinding Wheel Coarse	4412513
Sanding Belt Set (5Pcs)	4419809

Spare parts can be ordered from the Special Orders Desk at your local Bunnings Warehouse.

For further information, or any parts not listed here, visit www.ozito.com.au or contact Ozito Customer Service:

Australia 1800 069 486

New Zealand 0508 069 486

E-mail: enquires@ozito.com.au

ELECTRICAL SAFETY

 **WARNING!** When using mains-powered tools, basic safety precautions, including the following, should always be followed to reduce risk of fire, electric shock, personal injury and material damage.

Read the whole manual carefully and make sure you know how to switch the tool off in an emergency, before operating the tool. Save these instructions and other documents supplied with this tool for future reference.

The electric motor has been designed for 230V and 240V only. Always check that the power supply corresponds to the voltage on the rating plate.

Note: The supply of 230V and 240V on Ozito tools are interchangeable for Australia and New Zealand.

Note: The power outlet used for the grinder must be protected by a 30mA residual current device or earth leakage circuit breaker.

The supply cord assessed as type Y attached by using AS/NZS 60335.1.

If the supply cord is damaged, it must be replaced by an electrician or a power tool repairer in order to avoid a hazard.

Using an Extension Lead

Always use an approved extension lead suitable for the power input of this tool. Before use, inspect the extension lead for signs of damage, wear and ageing. Replace the extension lead if damaged or defective.

When using an extension lead on a reel, always unwind the lead completely. Use of an extension lead not suitable for the power input of the tool or which is damaged or defective may result in a risk of fire and electric shock.

GENERAL POWER TOOL SAFETY WARNINGS

 **WARNING!** Read all safety warnings and all instructions. Failure to follow the warnings and instructions may result in electric shock, fire and/or serious injury. Save all warnings and instructions for future reference. The term "power tool" in the warnings refers to your mains-operated (corded) power tool or battery-operated (cordless) power tool.

1. **Work area safety**
 - a. **Keep work area clean and well lit.** Cluttered or dark areas invite accidents.
 - b. **Do not operate power tools in explosive atmospheres, such as in the presence of flammable liquids, gases or dust.** Power tools create sparks which may ignite the dust or fumes.
 - c. **Keep children and bystanders away while operating a power tool.** Distractions can cause you to lose control.
2. **Electrical safety**
 - a. **Power tool plugs must match the outlet. Never modify the plug in any way. Do not use any adapter plugs with earthed (grounded) power tools.** Unmodified plugs and matching outlets will reduce risk of electric shock.
 - b. **Avoid body contact with earthed or grounded surfaces, such as pipes, radiators, ranges and refrigerators.** There is an increased risk of electric shock if your body is earthed or grounded.
 - c. **Do not expose power tools to rain or wet conditions.** Water entering a power tool will increase the risk of electric shock.
 - d. **Do not abuse the cord. Never use the cord for carrying, pulling or unplugging the power tool. Keep cord away from heat, oil, sharp edges or moving parts.** Damaged or entangled cords increase the risk of electric shock.
 - e. **When operating a power tool outdoors, use an extension cord suitable for outdoor use.** Use of a cord suitable for outdoor use reduces the risk of electric shock.
 - f. **If operating a power tool in a damp location is unavoidable, use a residual current device (RCD) protected supply.** Use of an RCD reduces the risk of electric shock.
3. **Personal safety**
 - a. **Stay alert, watch what you are doing and use common sense when operating a power tool. Do not use a power tool while you are tired or under the influence of drugs, alcohol or medication.** A moment of inattention while operating power tools may result in serious personal injury.
 - b. **Use personal protective equipment. Always wear eye protection.** Protective equipment such as dust mask, non-skid safety shoes, hard hat, or hearing protection used for appropriate conditions will reduce personal injuries.
 - c. **Prevent unintentional starting. Ensure the switch is in the off-position before connecting**

to power source and/or battery pack, picking up or carrying the tool. Carrying power tools with your finger on the switch or energising power tools that have the switch on invites accidents.

- d. **Remove any adjusting key or wrench before turning the power tool on.** A wrench or a key left attached to a rotating part of the power tool may result in personal injury.
- e. **Do not overreach. Keep proper footing and balance at all times.** This enables better control of the power tool in unexpected situations.
- f. **Dress properly. Do not wear loose clothing or jewellery. Keep your hair, clothing and gloves away from moving parts.** Loose clothes, jewellery or long hair can be caught in moving parts.
- g. **If devices are provided for the connection of dust extraction and collection facilities, ensure these are connected and properly used.** Use of dust collection can reduce dust-related hazards.
4. **Power tool use and care**
 - a. **Do not force the power tool. Use the correct power tool for your application.** The correct power tool will do the job better and safer at the rate for which it was designed.
 - b. **Do not use the power tool if the switch does not turn it on and off.** Any power tool that cannot be controlled with the switch is dangerous and must be repaired.
 - c. **Disconnect the plug from the power source and/or the battery pack from the power tool before making any adjustments, changing accessories, or storing power tools.** Such preventive safety measures reduce the risk of starting the power tool accidentally.
 - d. **Store idle power tools out of the reach of children and do not allow persons unfamiliar with the power tool or these instructions to operate the power tool.** Power tools are dangerous in the hands of untrained users.
 - e. **Maintain power tools. Check for misalignment or binding of moving parts, breakage of parts and any other condition that may affect the power tool's operation. If damaged, have the power tool repaired before use.** Many accidents are caused by poorly maintained power tools.
 - f. **Keep cutting tools sharp and clean.** Properly maintained cutting tools with sharp cutting edges are less likely to bind and are easier to control.
 - g. **Use the power tool, accessories and tool bits etc. in accordance with these instructions, taking into account the working conditions and the work to be performed.** Use of the power tool for operations different from those intended could result in a hazardous situation.
5. **Service**
 - a. **Have your power tool serviced by a qualified repair person using only identical replacement parts.** This will ensure that the safety of the power tool is maintained.
 - b. **If the supply cord is damaged, it must be replaced by the manufacturer, its service agent or similarly qualified persons in order to avoid a hazard.**

BENCH GRINDER & BELT SANDER SAFETY WARNINGS

 **WARNING!** To avoid mistakes that could cause serious permanent injury, do not plug the bench grinder/sander in until the following steps are completed:

- Assembly and alignment
- Review and understand all safety instructions and operating procedures in this manual.
- Avoid fire. Clean out all sawdust and disconnect from any vacuum before sanding metals.
- Bolt the bench grinder/sander to a firm level surface where there is plenty of room for handling and properly supporting the workpiece.
- Never stand on the tool. Serious injury could occur if the tool tips.
- Remove adjusting keys and wrenches from tool before turning it on.
- Make sure all clamps and locks are tight and no parts have excessive play.
- Never use the bench sander near flammable liquids, vapours or gases.
- Make sure there are no nails or foreign objects in the part of the workpiece to be sanded.
- Make sure there are no debris between the workpiece and its supports.
- When sanding irregularly shaped workpieces, plan your workpiece support so it will not slip and be pulled from your hands.
- Use extra caution with large, very small or awkward workpieces.
- Never use this tool to finish pieces too small to hold by hand.
- Sand only one workpiece at a time.
- Clear everything except the workpiece and related support devices off the table before turning the bench grinder/sander on.
- Plan the way you will hold the workpiece from start to finish.
- Avoid awkward operations and hand positions where a sudden slip could cause fingers or hand to move into a sanding surface. Keep fingers away from where the belt goes into the dust trap.
- Always remove the plug from the mains socket before making any adjustments or maintenance, including changing the wheel or belt.
- Always turn the bench grinder/sander off when it is not in use and never leave it unattended without first switching off and removing the power plug. Never leave the bench grinder/sander until the grinding wheels and sanding belt have come to a complete stop.
- Use only grinding wheels which are marked with details of the manufacturer, the type of bonding agent used, dimensions and the permissible RPM.
- Do not let anyone under 18 years operate this tool.
- Rags, cloths, cord, string and the like should never be left around the work area.
- If you are interrupted when operating the tool, complete the process and switch off before looking up.
- Periodically check that all nuts, bolts and other fixings are properly tightened.
- Do not use a wheel that has received a blow, especially to the side of the wheel.

- Replace a cracked or suspect wheel.
- Always allow a new wheel to run for a few minutes at full speed before using it. Stand to one side at start up.
- Check that the wheel rotates freely each time before start up.
- Do not use the bench grinder/sander unless all the guards are properly fitted and secure.
- Check that the workpiece supports are properly adjusted before commencing use.
- Do not overload the bench grinder/sander. Allow the bench grinder/sander to run at full speed, or close to full speed during use.
- Never apply excessive pressure to the wheel. It might shatter causing personal injury.
- Make sure that the wheel or belt is not in contact with the workpiece when you start the tool.
- When using the bench grinder/sander, use safety equipment including safety goggles or shield, ear protection, dust mask and protective clothing including safety gloves.
- To prevent damage to the power cable, always lead it away from the rear of the machine.
- Use on materials containing asbestos is prohibited.
- Grinding wheels must be stored in a dry place, ideally at a constant temperature.
- Use only the clamping flanges supplied with the equipment to mount the grinding wheels.
- Never enlarge a grinding wheel's mounting hole by subsequent drilling.
- The workpiece supports and the top adjustable safety guards must always be moved as close as possible to the grinding wheel and belt (max. 2 mm clearance).
- Max. permitted motor housing temperature: 80°C
- Adjust the spark deflector periodically in order to compensate the wear of the wheel. Please note that the distance between the spark deflector and the wheel is to be kept as small as possible and should in no case exceed 2mm.
- The grinding wheel must be replaced at the latest when the spark deflector and the workpiece support can no longer be set a maximum distance of 2mm from the grinding wheel.
- The machine may exceed 85 db (A) at the workplace. The operator will require noise protection measures and ear muffs if this is the case.

Even if you use this electric power tool in accordance with instructions, certain residual risks cannot be ruled out. The following hazards may arise in connection with the equipment's construction and layout:

- Lung damage if no suitable protective dust mask is used.
- Damage to hearing if no suitable ear protection is used.
- Health damage caused by hand-arm vibrations if the equipment is used over a prolonged period or is not properly guided and maintained.
- Contact with the grinding wheel where it is not covered.
- Catapulting of parts from out of damaged grinding wheels.
- Catapulting of workpieces and parts of workpieces.