

# AlfrescoPlus™

**SINGLE / DOUBLE STORAGE MODULE  
AND  
SINGLE / DOUBLE SINK MODULE**

## **ASSEMBLY INSTRUCTIONS**



**OR**



Also included (if required)  
- How to install the sink module.

For further instruction, please visit:  
[www.alfrescoplus.com.au](http://www.alfrescoplus.com.au)

# WARNING! – THIS IS A PERMANENT CONNECTION SYSTEM!

## WHAT'S NEEDED?

### Tools Required:

- Soft Sided Hammer (Not Included)
- Philips head screwdriver (Not Included)
- Allen Keys x 2 (Included)

## WHAT'S IN THE BOX?

**Box 1 of 4 = Bench-top**

**Box 2 of 4 = Panels**

**Box 3 of 4 = Frames**

**Box 4 of 4 = Doors**

## PARTS INCLUDED:

### FRAMES

- Cabinet Frames (Various Profiles) x 12 + 1

### CORNER PRONGS

- Three prong x 8

### WHITE PANELS

x 6 + 1

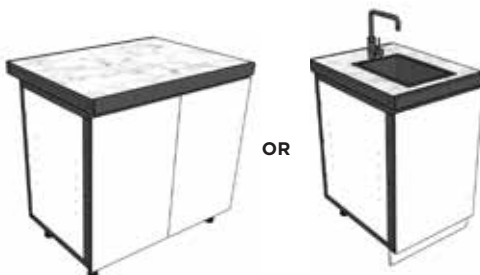
### PLINTH FEET

x 4

### HARDWARE

- Screws, small (Stone Top Frame) x 8
- Screws, medium (Plinth Feet) x 16
- Joining Bolts (Male/Female) x 4
- Allen Keys x 2
- Shelf Adjuster Points x 4
- Door Hinge Set x 2 (If Single Door)
- Door Hinge Set x 4 (If Double Door)

**Please note:** Follow all instruction in the same sequence, either building the SINGLE/DOUBLE storage modules or the SINGLE/DOUBLE sink modules.



## WHAT TO DO NEXT?

Remove all parts from the cartons. DO NOT unwrap the frames at this stage.

### Preparing the panels:

- Remove all the white panels from the carton and place in an easily accessible location (All red arrow labels to face upwards).
- Remove at least 10cm of plastic film alongside the edge of the panels, as per image.

**Essential TIP:** DO NOT remove all the plastic film from the panels, since the 4 way red arrows are an integral part of the assembly process.

The red arrow stickers are placed on top of the plastic on most panels and therefore the plastic should not completely be removed at this stage.



**Essential TIP:** Ensure you have a stable flat surface or workbench to work from. The most ideal height to assemble the module is waist height. The workbench should be at least 1.8m (W) x 1m(H) x 0.7m(D) in size.

## LAYOUT DIAGRAM



**FIG. 1**

## ASSEMBLING BACK PANEL

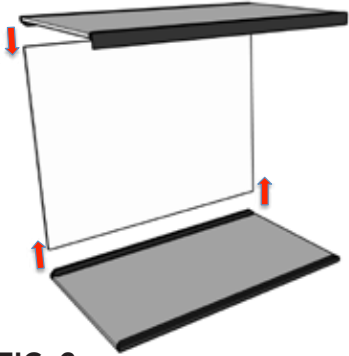


FIG. 2



FIG. 3

## ASSEMBLING SIDE WALL PANELS TO BACK PANEL

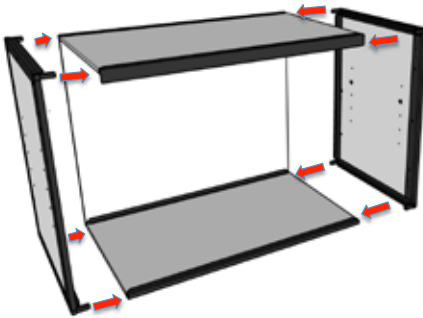


FIG. 4

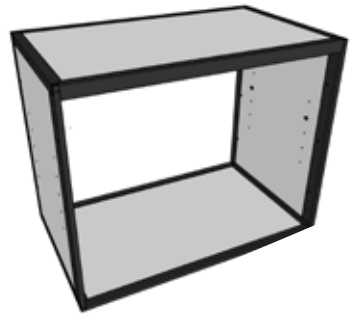


FIG. 5

## ASSEMBLING SHELF PANEL

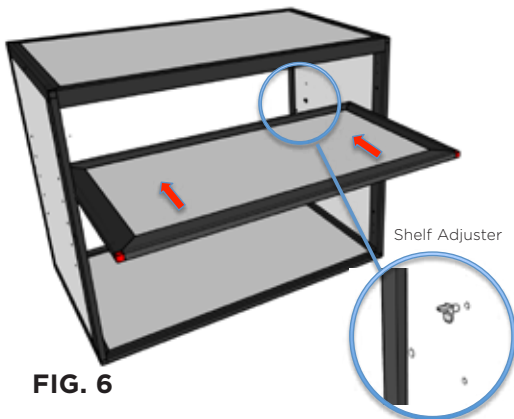


FIG. 6



FIG. 7

## ASSEMBLING THE ADJUSTABLE PLINTH FEET

No Allocating holes are used for plinth feet since the inside frame edge provides the guide. Place Plinth foot into corner of cabinet frame. Screw down with screws provided. If easier, remove plinth shaft from baseplate then screw down base plate first. If desired move the front two plinth feet further back to create a deeper kick-plate position.



FIG. 8

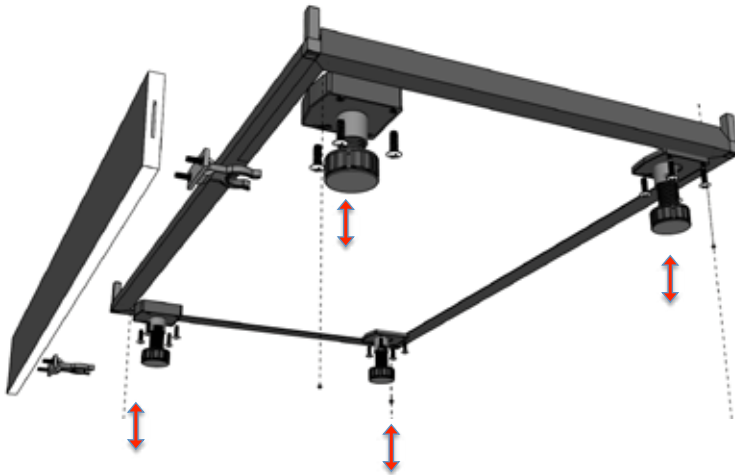
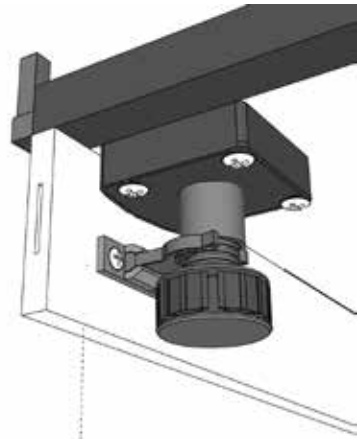
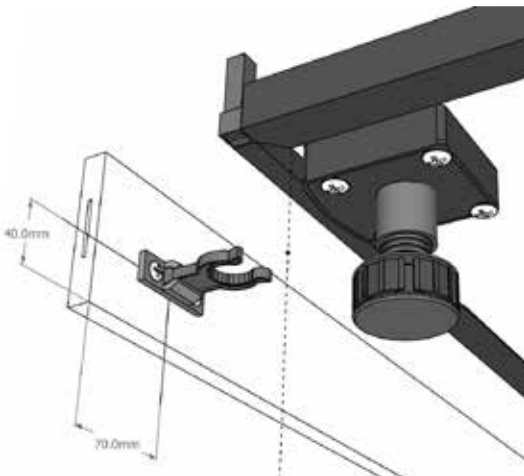
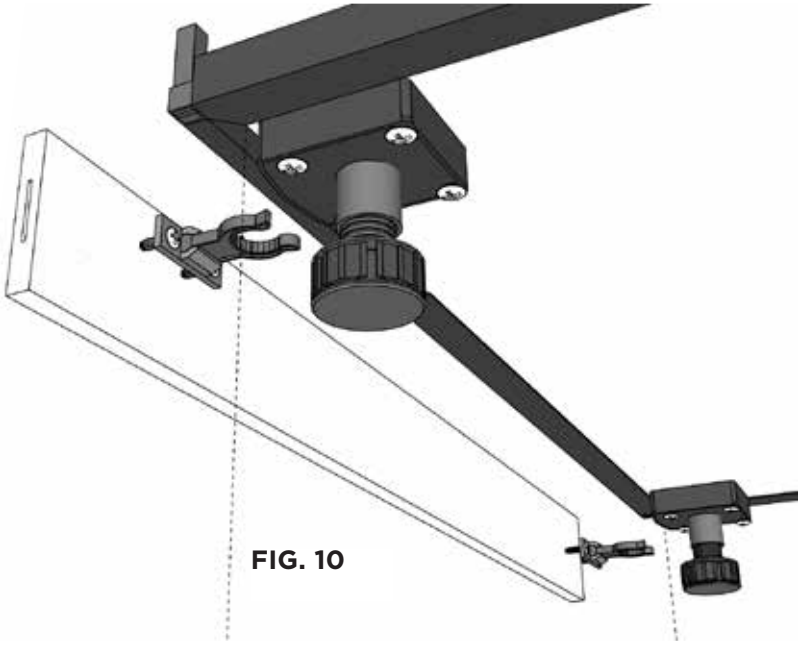


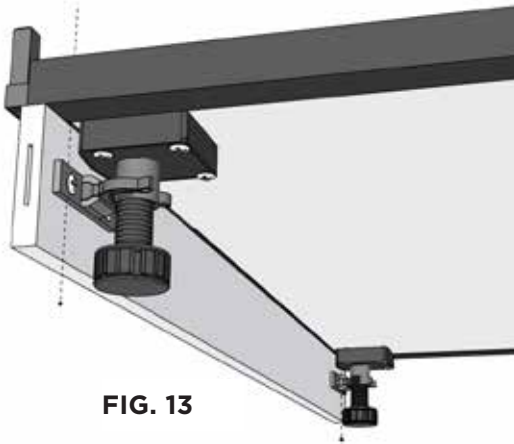
FIG. 9

## ATTACHING THE KICK PLATE

Please take note that the Kick plate provided is reversible, thereby giving you the choice between a black "shadow line" finish or stylish silver finish. The Kick plate Biscuit is used to connect onto more than one cabinet, thereby aligning the kick plate.



Choose the desired color face of kick plate. (Silver or Black). No pre drilled holes are possible due to this color choice. Self tapping screws are provided to attach the spring clip plate to the kick panel. The dimensions on Fig. 11 can be used as a guide only since the position of the plinth foot and the desired depth of the kick plate will vary depending on the choice of plinth foot installation position by the end user.



**FIG. 13**

## ASSEMBLING DOOR & HINGES

- To attach the hinge plate use a standard or power Phillips head screw driver. The allocating holes are pre drilled into the frame.
- Attach all four-hinge plates when attaching two doors. Attach the two-left hinge plates when attaching a single door.

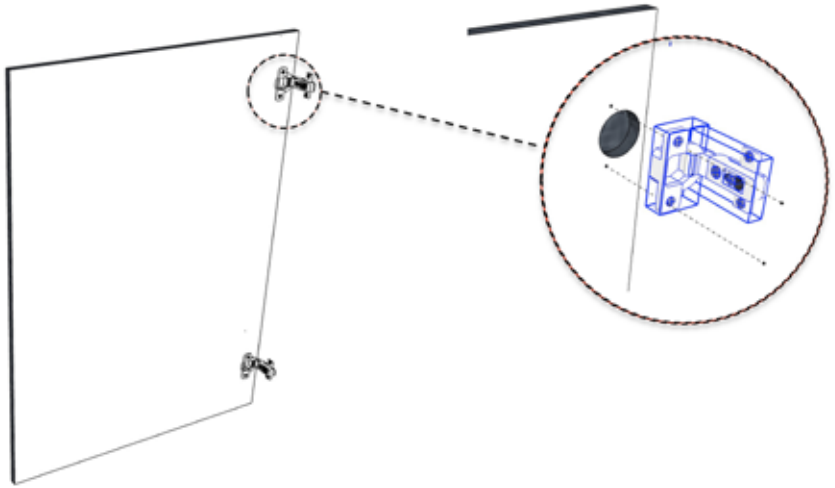


Attach provided  
Hinge Plate x 4 and  
self tapping screws.

**FIG. 14**

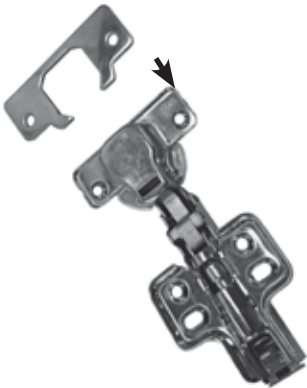


Illustration on attaching hinges to door panels by using the self-tapping screws provided.



**FIG. 15**

Each door hinge includes a spacing bracket



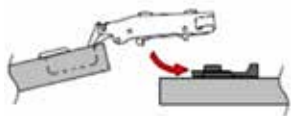
Place the spacing bracket on the underside of the door hinge before assembly



Screw the door hinge to the door panel with the bracket in place as shown



\* Detailed INSTRUCTIONS on how to clip on the doors using clip-on-hinges.

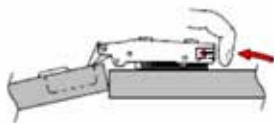


**Clip On Hinge Instructions:**

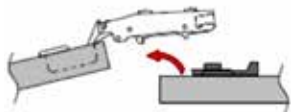
Clamp hinge on to the mounting plate as shown by direction arrow



Press down the hinge arm to lock the plate as shown



The door can be quickly removed by pushing the button



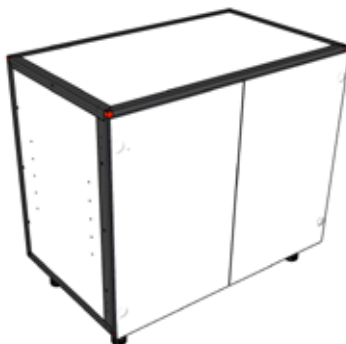
Unclipping the door from the mounting plate leaves all adjustments unaltered

Firstly align the front hinge section with the front section of the hinge-plate, then press on the back of the hinge-plate, an audible “Click” should be heard if the door has been correctly hanged. Repeat the process to secure the bottom hinge and door.



**FIG. 16**

The door should fully open and close as normal.



**FIG. 17**

At this stage your progress should look like the above image. Choose any separate style of door handle and fit according to the manufacturers.

## STONE TOP PLACEMENT (G)

The frame and stone top is pre-assembled for your ease of assembly.

**Essential TIP:** Ensure the frames and stone table are positioned on a stable flat surface to ensure alignment. Caution: The stone table is very heavy, and a 2-person lift is required.



**FIG. 18**

Ensure that the front frame edge of the stone top is positioned to create an overhang of at least 20mm

**WARNING! - The stone-top positioning and alignment is the last step of assembling your module and BBQ kitchen setup. The double side VHB tape creates a very strong permanent bond and cannot be moved once contact has been made.**

Take note that the 3M VHB tape is a permanent Very High Strength adhesion. Align the front of the frame with the BBQ front then lower onto the cabinet for a permanent bond.

Gently lower the stone top and frame onto the module cabinet. Ensure that both ends of the frame and stone are lowered in a horizontal position thereby being flush with the Cabinet top frame. Instead of using the 3M VHB tape you have the option to drill holes from the inside of the cabinet and make use of screws (not provided) to attach the stone top.

For Further instruction on door adjustment and leveling please visit:  
[www.alfrescoplus.com.au](http://www.alfrescoplus.com.au)



**FIG. 19**

## HOW TO INSTALL THE SINK MODULE

**Step 1:** Ensure that the top white panel is NOT installed into the frame. This panel is not provided with our standard sink module however if you are converting a single or double solid top module into a sink top, then create a suitable cutout into the top of the cabinet by using a hole saw and jig saw if required.



**FIG. 20**



**FIG. 21**

This top white panel is provided in the single and double solid top module but do not install for sink module.



**FIG. 22**

This is how the single or double sink module should look after fully assembled.

**Step 2:** Install the stone top as per the steps provided



**FIG. 23**

**Step 3:** Align the sink with the pre cut hole in the stone top.



**FIG. 24**

**Step 4:** Lower the sink into the pre cut hole in the stone. If a permanent installation is required liquid silicone adhesive may be used under the metal flange of the sink.



**FIG. 25**

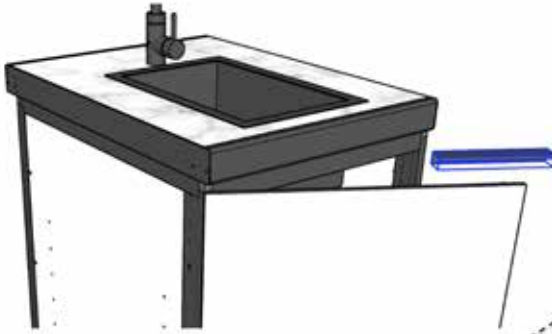
**Step 5:** Place the sink tap into the pre cut hole provided. Screw the base of the tap into place by screwing from the bottom of the sink. Your tap will then be securely in position. Please note a registered plumber is now required to plumb into your water mains.



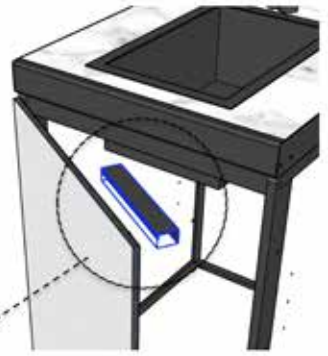
**FIG. 26**

## HOW TO INSTALL A DOOR HANDLE

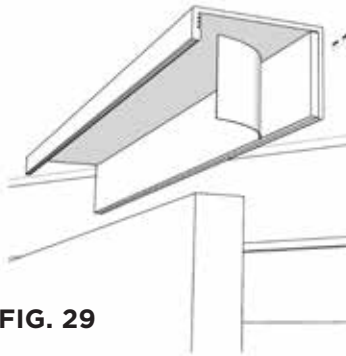
Take note that the door handles can be placed vertically or horizontally as preferred by you.



**FIG. 27**



**FIG. 28**

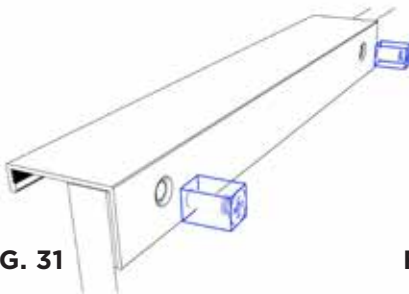


**FIG. 29**

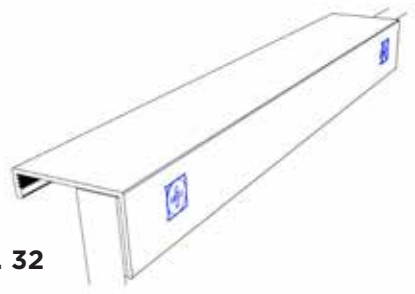


**FIG. 30**

Remove the Double sided Tape from the inside of the handle. Ensure you align the edge of the handle to the edge of the door before touching the tape to the door panel. Carefully press the door handle to the door for a permanent adhesion.



**FIG. 31**



**FIG. 32**

Additional screws are provided for a very secure connection, although you need to drill your own holes due to the handle having multiple possible positions as desired. These additional screw fixtures are not required under normal use.

For any queries or assistance call:

**Customer Service**

Australia Only

**1300 174 876**

Hours of operation:  
Monday to Friday 8am - 5pm

**Do not return to place of purchase**

Keep your purchase receipt, this will be required to make  
any claims under the 12 month warranty

**AlfrescoPlus™**