

POOL SAFE GATE KIT INSTALLATION



TRUST IN QUALITY: The Pool Safe Gate Kit has been designed for optimum safety & ease of installation

G8SAFE SAFETY CHECKLIST

- ✓ Hinges are tension adjustable and self closing
- ✓ Latch cannot be locked in the open position
- ✓ Patented self-latching mechanism, latches without any pressure
- ✓ Latch cannot be prised or shaken open
- ✓ Tested to AS1926.1-2012
- ✓ Superior Quality, hinges hold 45kg
- ✓ Hinge safety cone to prevent climbing

HINGES

1. Mark and fix hinges to gate. Distance between top of hinges must be minimum of 900mm (Pic. A), if this isn't possible Hinge Cone (supplied) must be fitted to the bottom hinge (Pic. E).
2. Align gate with hinge post and fix hinges to post (Pic B)
3. To Adjust hinge tension, simply use supplied tool (see adjustment diagrams).
 - ONE tension click per hinge at a time
 - Check for desired gate tension after each adjustment.
 - Aim for equal amounts of tension clicks on each hinge.
 - Maximum FOUR tension clicks per hinge.
 - Once adjusted fit the supplied covers to top of hinges (Pic C).
4. Safety cone reduces the risk of children using the hinge as a foothold to climb over the gate. Must be fitted to the bottom hinge if the top of the hinges are less than 900mm apart.

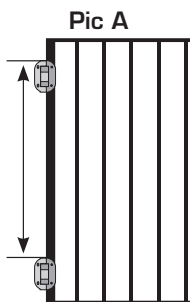

Pic A: hinges must be spaced minimum 900mm from top to top

Pic B



Pic C



Pic D



Pic E



ADJUSTMENT DIAGRAMS

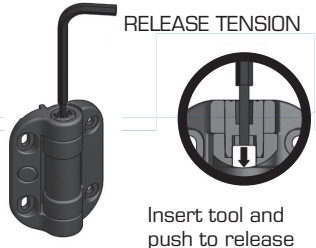
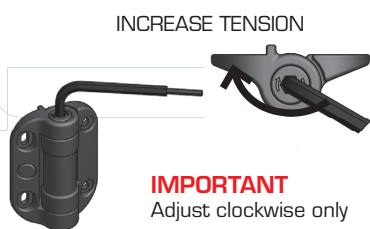

Available at
BUNNINGS
warehouse

G8SAFE
.com.au
CREATING WAVES FOR POOL SAFETY

Proudly endorsed by:

EVERYONE CAN BE A LIFESAVER



Royal Life Saving

ROYAL LIFE SAVING SOCIETY - AUSTRALIA

Water Safety
NEW ZEALAND

Step 1 & 2

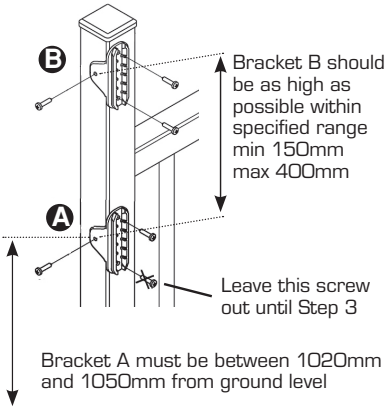

Step 3

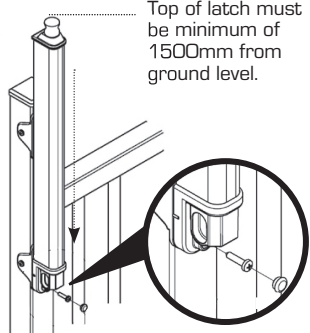

LATCH

1. Position latch bracket A (lower bracket) between 1020mm & 1050mm from ground level. Fix to post with two screws, leaving the bottom screw out until later (Step 3).
2. Place latch bracket B (upper bracket) as high as possible within specified range from bracket A – min. 150mm, max 400mm.
3. Starting at the top slide latch body fully down onto brackets, then screw to lower bracket.

STRIKER

4. Align Striker bracket with latch using the alignment notches.
5. Screw bracket to gate using screws provided.
6. Slide Striker onto bracket, fix using adjuster screw
7. Adjust striker clearance 3mm-6mm turning the adjuster screw clockwise to increase.

Step 4

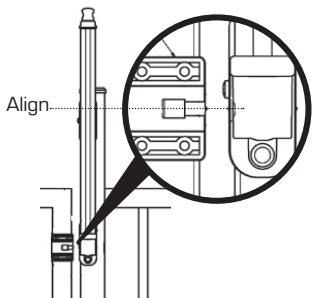

Step 5

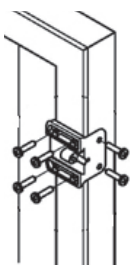

Step 6

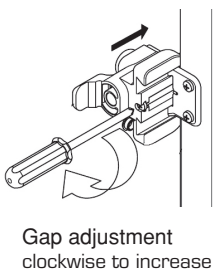

Step 7

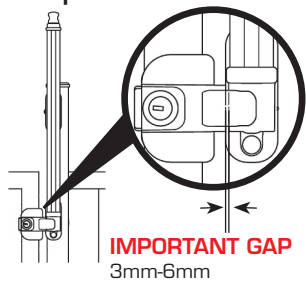

HANDLE

Optional handle can be fixed to gate if required.



9 338797 020927

G8SAFE

.com.au

CREATING WAVES FOR POOL SAFETY