

Orlando

Slow Release Roller Blind

INSTALLATION INSTRUCTIONS

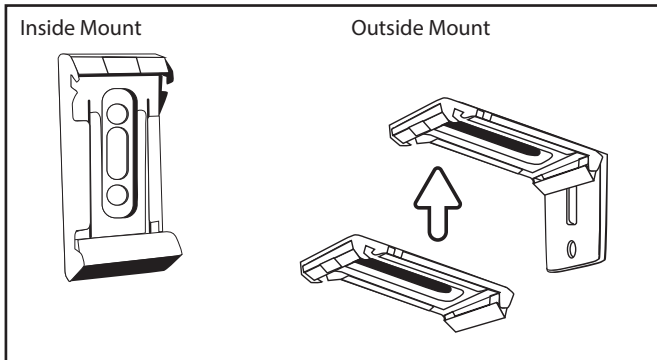

Step 1)
Decide how the blind is to be fitted. Inside mount (inside top of window frame) or outside mount (face of architrave or wall).

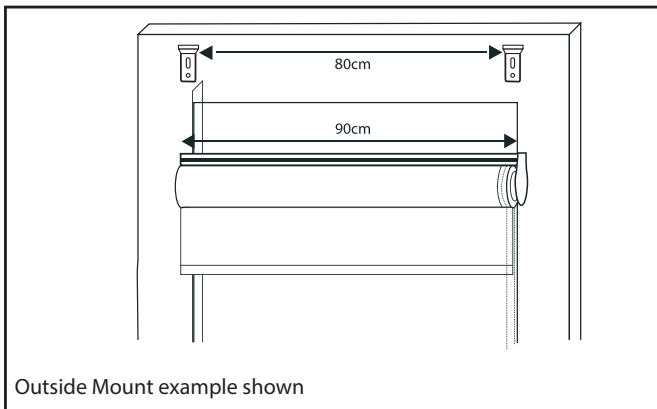

Step 2)
Using a pencil, mark the positions for fixing the brackets, ensuring they are all fixed at the same level. Ensure position of bracket is at least 10cm from each end of the blind.

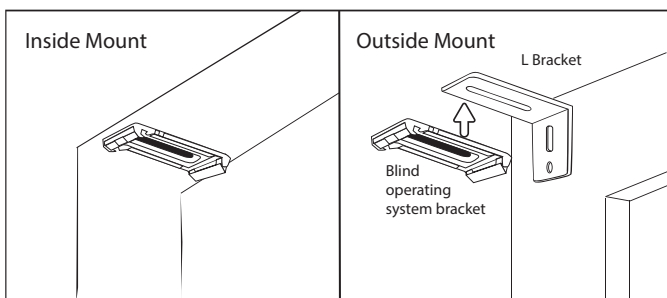

Step 3)
Inside Mount (Top fixing) - Carefully pre drill holes and secure blind operating system brackets using screws provided. Use a phillips head screw driver to attach the brackets to the window frame. Ensure brackets are facing the correct way.
Outside mount - carefully pre drill holes and secure L shape wall brackets. Use a phillips head screw driver to attach the brackets to the architrave or wall, using screws and wall plugs provided. Attach blind operating system brackets to the wall brackets with the nut and bolt provided.

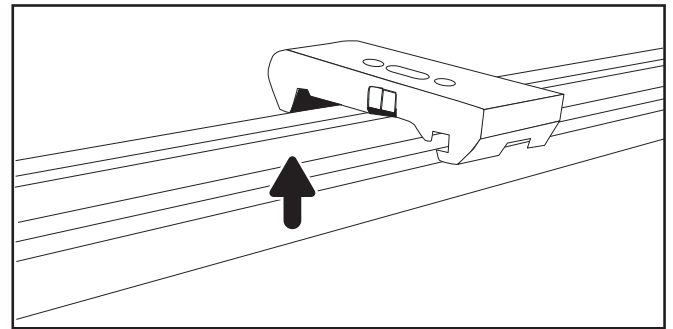

Step 4)
Attach the blind operating system to the brackets by lifting the blind into the brackets by locking the front groove of the head rail into the front of the bracket.

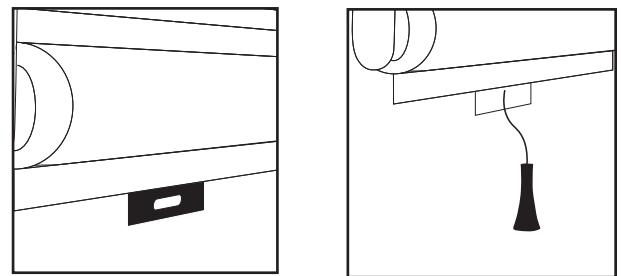

Step 5)
The blind includes a ring pull and tassel for added convenience of operation. You can choose to have one, both or none attached to the bottom rail of the blind. Use the allen key provided to fix the ring pull or tassel.

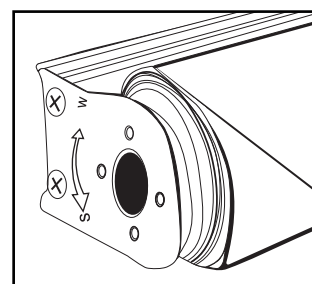

Step 6)
Test the speed of blind operation. To adjust operation of the blind to be faster or slower, the tension can be easily adjusted to accommodate to the left speed. Using a flat blade screwdriver on the left side of the head rail, turn the plastic tension disc towards "S" to speed up or "W" to slow down.

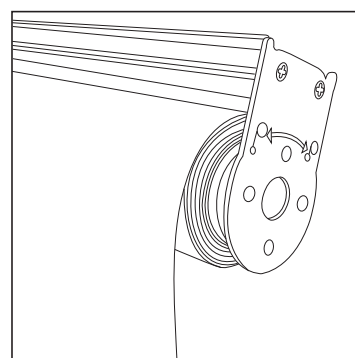

Step 7)
To adjust the hanging position of the blind, the height can be easily adjusted. Using a flat blade screwdriver on the right side of the head rail, turn the plastic tension disc towards P to hang shorter or P to hang longer.