

RYOBI®

RGN3800A

PORTABLE GENERATOR SET OPERATOR'S MANUAL

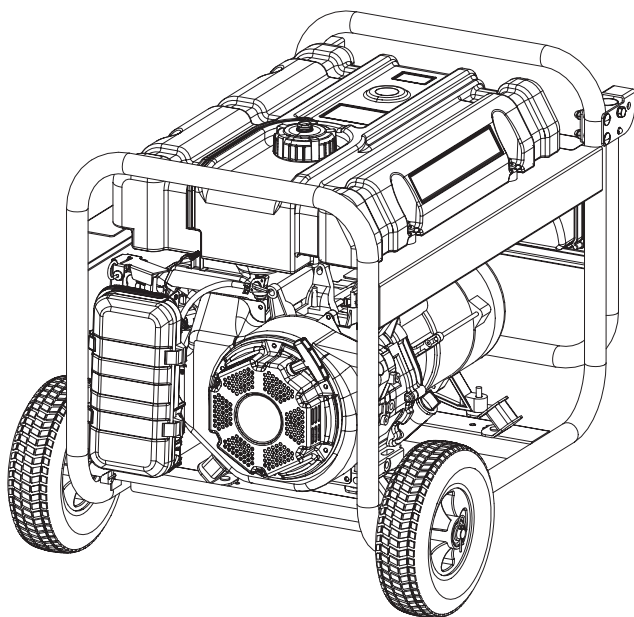

Important!

It is essential that you read the instructions in this manual before assembling, maintaining and operating this machine.

Subject to technical modifications.

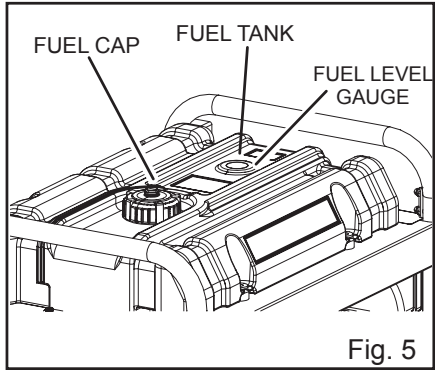
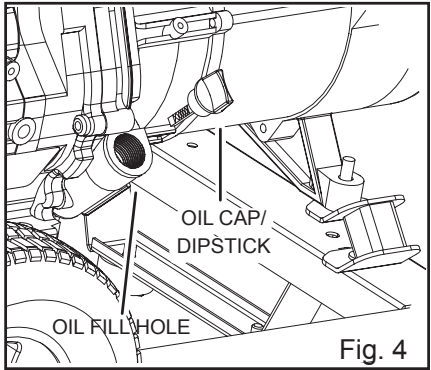
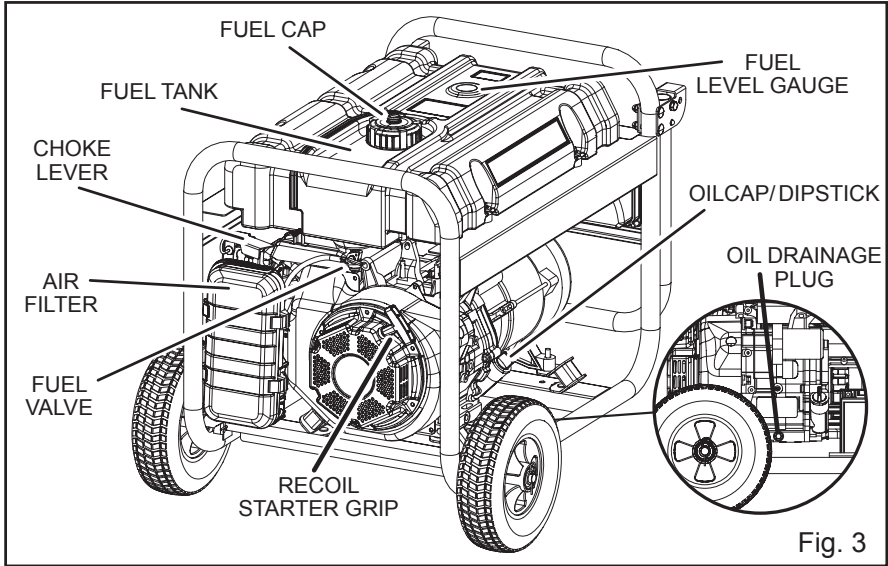
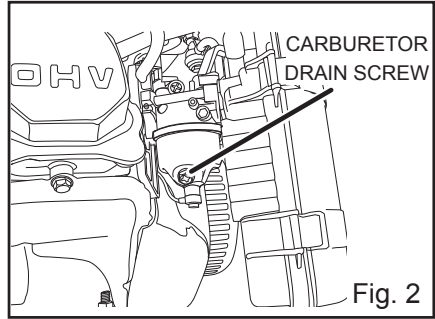
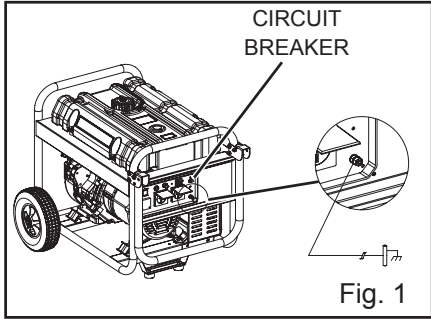

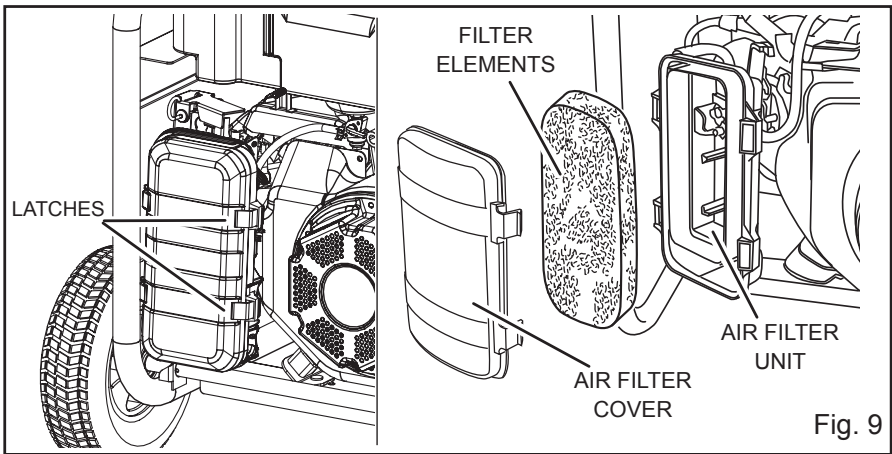
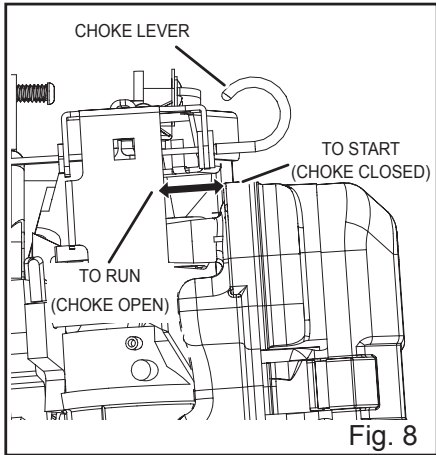
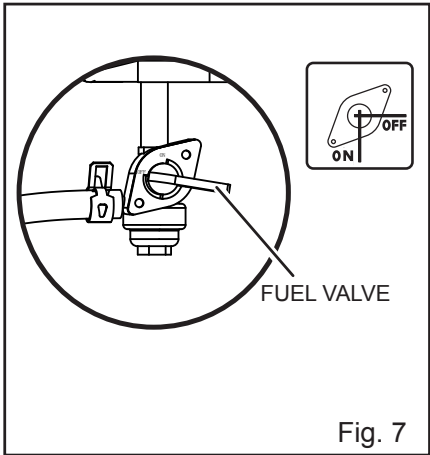
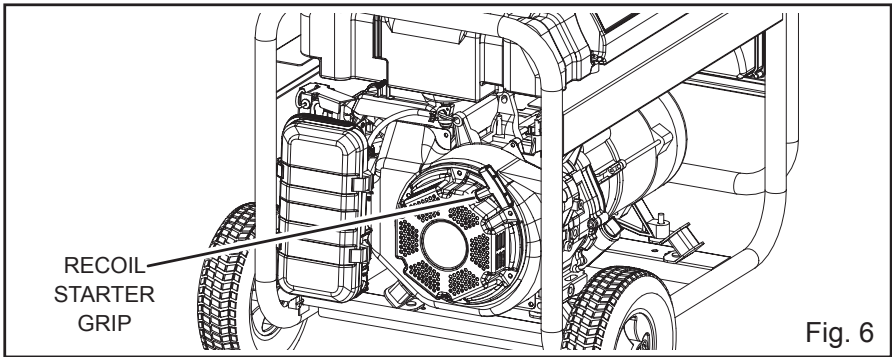

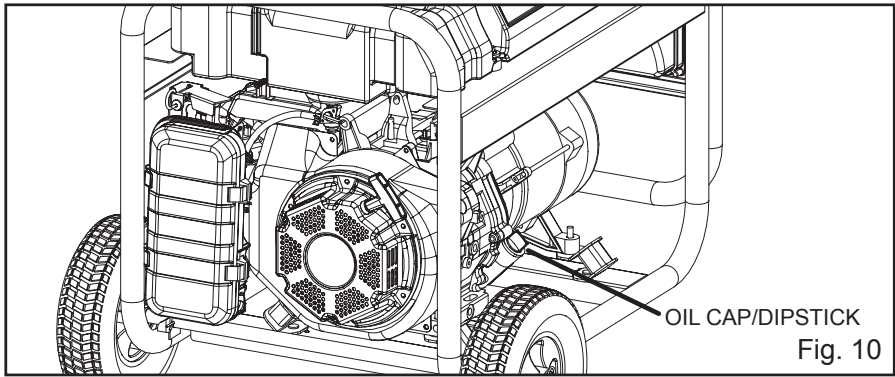

Fig. 10

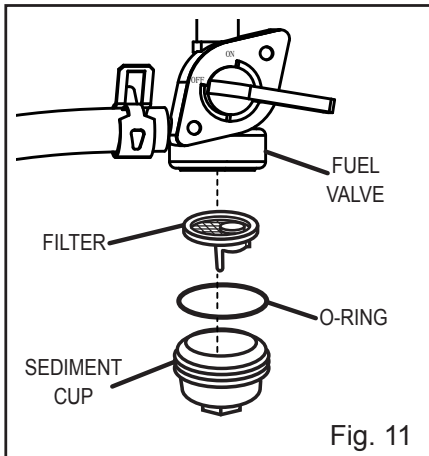

Fig. 11

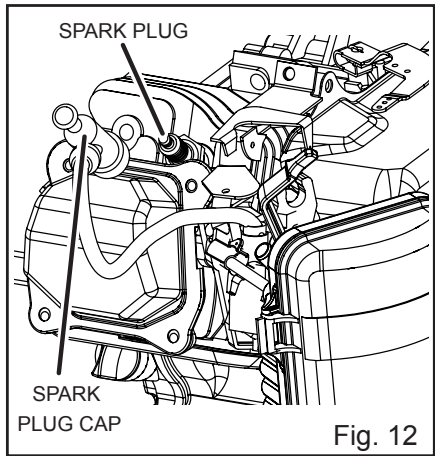

Fig. 12

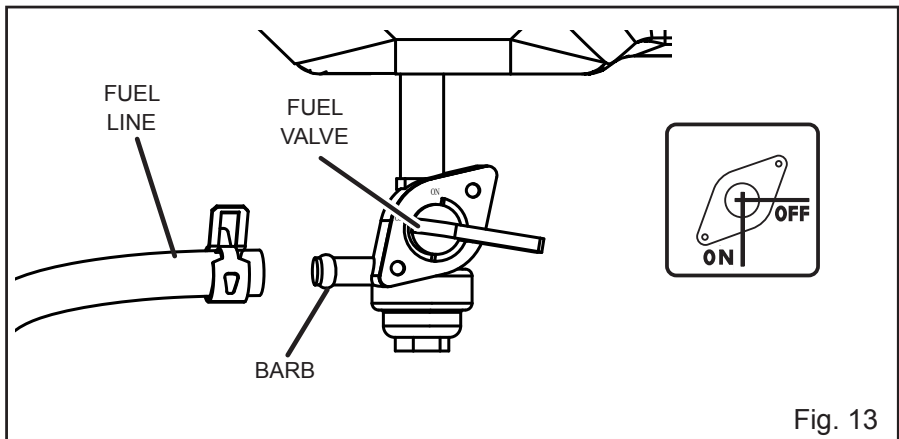

Fig. 13

English

INTRODUCTION

This product has many features for making its use more pleasant and enjoyable. Safety, performance, and dependability have been given top priority in the design of this product, making it easy to maintain and operate.



DANGER

GROUND THE GENERATOR (See Figure 1)

In Australia and New Zealand, grounding of portable generators is not recommended or required. Consult with local electricians to determine grounding requirements before operating with a ground connection.

GENERAL SAFETY RULES



WARNING:

Read and understand all instructions. Failure to follow all instructions listed below may result in electrocution, fire, and/or carbon monoxide poisoning, which will cause death or serious injury.



WARNING:

Before using the ground terminal, consult a qualified electrician to comply with the intended use of the generator.

SAVE THESE INSTRUCTIONS

This manual contains important instructions that should be followed during installation and maintenance of the generator and batteries.

- Do not allow children or untrained individuals to use this unit.
- Never start or run the engine inside a closed or partially enclosed area. Breathing exhaust fumes will kill you.
- Wear eye protection as well as hearing protection when operating this equipment.
- Keep all bystanders, children, and pets at least 3m away.
- Wear sturdy and dry shoes or boots. Do not operate while barefoot.
- Do not operate the generator when you are tired or under the influence of drugs, alcohol, or medication.
- Keep all parts of your body away from any moving parts and all hot surfaces of the unit.
- This product is equipped with a spark arrestor in accordance with Australian requirements.
- Do not touch bare wire or receptacles.
- Do not use the generator with electrical cords which are worn, frayed, bare, or otherwise damaged.
- Before storing, allow the engine to cool.
- Do not operate the generator in rain, snow, or wet weather.
- Empty fuel tank, close fuel valve, and restrain the unit from moving before transporting in a vehicle.
- Allow engine to cool for five minutes before refueling.
- To reduce the risk of fire and burn injury, handle fuel with care. It is highly flammable.
- Do not smoke while handling fuel.
- Store fuel in a container approved for unleaded fuel.
- Position the unit on level ground, stop engine, and allow to cool before refueling.
- Loosen fuel cap slowly to release pressure and to keep fuel from escaping around the cap.
- Tighten the fuel cap securely after refueling.
- Wipe spilled fuel from the unit.
- Never attempt to burn off spilled fuel under any circumstances.
- Use only authorised replacement parts and accessories and follow instructions in the Maintenance section of this manual. Use of unauthorised parts or failure to follow Maintenance instructions may create a risk of shock or injury.
- Maintain the unit per maintenance instructions in this Operator's Manual.
- Inspect the unit before each use for loose fasteners, fuel leaks, etc. Replace damaged parts.
- Generators vibrate in normal use. During and after the use of the generator, inspect the generator as well as extension cords and power supply cords connected to it for damage resulting from vibration. Have damaged items repaired or replaced as necessary. Do not use plugs or cords that show signs of damage such as broken or cracked insulation or damaged blades.

English

SPECIFIC SAFETY RULES



WARNING:















When this generator is used to supply a building wiring system: the generator must be installed by a qualified electrician and connected to a transfer switch as a separately derived system in accordance with Australian Wiring Rules, National Electrical Code. The generator shall be connected through a transfer switch that switches all conductors other than the equipment grounding conductor. Failure to isolate the generator from power utility can result in death or injury to electric utility workers.

- Exhaust fumes contains poisonous carbon monoxide, a colourless, odourless gas. Breathing exhaust fumes can cause loss of consciousness and can lead to death. If the generator is running in a confined or partially-enclosed area, the air may contain a dangerous amount of carbon monoxide. To keep exhaust fumes from building up, always provide adequate ventilation.
 - Always use a battery-powered carbon monoxide detector when running the generator. If you begin to feel sick, dizzy, or weak while using the generator, shut it off and get to fresh air immediately. See a doctor. You may have carbon monoxide poisoning.
 - Place the generator on a flat, stable surface with a slope of no more than 4°.
 - Operate in a well-ventilated, well-lit area isolated from working areas to avoid noise interference.
 - Operating the generator in wet conditions could result in electrocution. Keep the unit dry.
 - Keep the generator a minimum of 1m away from all types of combustible material.
 - Do not operate the generator near hazardous material.
 - Do not operate the generator at a petrol station.
 - Do not touch the muffler or cylinder during or immediately after use; they are HOT and will cause burn injury.
 - Do not connect to a building's electrical system unless a transfer switch has been properly installed by a qualified electrician.
 - Do not allow the generator's fuel tank to overflow when filling. Fill to 25mm below the top neck of the unleaded fuel tank to allow for fuel expansion. Check the ventilation hole inside the fuel tank cap for debris. Do not block the vent.
- Do not smoke when filling the generator with unleaded fuel.
 - Allow the engine to remain in a shut-down condition for at least five minutes before adding unleaded fuel or oil.
 - Do not remove the oil dipstick or the fuel tank cap when the engine is running.
 - Pay close attention to all safety labels located on the generator.
 - Keep children a minimum of 3m away from the generator at all times.
 - The unit operates best in temperatures between 5°C and 40°C with a relative humidity of 30~95%.
 - Operation of the generator at altitudes above 1,000m may require retuning. Consult a qualified service technician.
 - When using extension lines or mobile distribution networks the total length of lines for a cross section of 1.5mm² should not exceed 60m; for a cross section of 2.5mm² this should not exceed 100m.
 - The generating set must not be connected to other power sources.
 - Save these instructions. Refer to them frequently and use them to instruct others who may use this tool. If you loan someone this tool, loan them these instructions also.



English

SYMBOLS

Some of the following symbols may be used on this tool. Please study them and learn their meaning. Proper interpretation of these symbols will allow you to operate the tool better and safer.



SYMBOL	DESIGNATION/EXPLANATION
	Do not expose to rain or use in damp locations.
	To reduce the risk of injury, the user must read and understand the operator's manual before using this product.
	Always wear safety goggles or safety glasses with side shields and, as necessary, a full face shield when operating this product.
	Precautions that involve your safety.
	Failure to use in dry conditions and to observe safe practices can result in electric shock.
	Running the generator gives off carbon monoxide, an odourless, colourless, poison gas. Breathing carbon monoxide can cause nausea, fainting, or death.
	Fuel and its vapours are extremely flammable and explosive. Fire or explosion can cause severe burns or death.
	To reduce the risk of injury or damage, avoid contact with any hot surface.
	To reduce the risk of serious injury, avoid attempting to lift the generator alone.
	Consult with local electrician to determine grounding requirements before operation.
	Regulatory Compliance Mark (RCM). Product meets applicable regulatory requirements.
	Guaranteed sound pressure level and sound power level.
	Beware of electric shock level.
	Fuel and its vapors are explosive and can cause severe burns or death.

English

	Add oil.
	Oil level should fall within the level indicator area on the dipstick.
	Waste electrical products should not be disposed of with household waste. Please recycle where facilities exist. Check with your Local Authority or retailer for recycling advice.

SYMBOLS

The following signal words and meanings are intended to explain the levels of risk associated with this product.

SYMBOL	SIGNAL	MEANING
	DANGER:	Indicates an imminently hazardous situation, which, if not avoided, will result in death or serious injury.
	WARNING	Indicates a potentially hazardous situation, which, if not avoided, could result in death or serious injury.
	CAUTION	Indicates a potentially hazardous situation, which, if not avoided, may result in minor or moderate injury.
	CAUTION	(Without Safety Alert Symbol) Indicates a situation that may result in property damage.

SERVICE

Servicing requires extreme care and knowledge and should be performed only by a qualified service technician. For service, contact your nearest authorised service centre for repair. When servicing, use only identical replacement parts.

 **WARNING:** Observe all normal safety precautions to avoid electrical shock.

 **DANGER:** To avoid death or serious personal injury, do not attempt to operate this product until you read thoroughly and understand completely the operator's manual. If you do not understand the warnings and instructions in the operator's manual, do not use this product. Call your nearest authorised service centre for assistance.

 **WARNING:** The operation of any products can result in foreign objects being thrown into your eyes, which can result in severe eye damage. Before beginning power tool operation, always wear safety goggles or safety glasses with side shields and, when needed, a full face shield. We recommend Wide Vision Safety Mask for use over eyeglasses or standard safety glasses with side shields. Always wear eye protection.

SAVE THESE INSTRUCTIONS

English

SYMBOLS

SAFETY LABELS

The information below can be found on the generator. For your safety, please study and understand all of the labels before starting the generator.

If any of the labels come off the unit or become hard to read, contact the authorised service centre for replacement.

FUEL WARNING

No smoking when filling with unleaded fuel. Do not overfill. Full level is 25 mm below the top of the fuel neck. Stop the engine for five minutes before refueling to avoid the heat from the muffler igniting fuel vapours.



WARNING

1. READ THE OPERATOR'S MANUAL AND ALL LABELS BEFORE OPERATING.
2. ONLY OPERATE IN WELL-VENTILATED AREA.
EXHAUST GAS CONTAINS POISONOUS CARBON MONOXIDE.
3. CHECK FOR SPILT FUEL OR FUEL LEAKS.
4. STOP ENGINE BEFORE REFUELING.
5. DO NOT OPERATE NEAR FLAMMABLE MATERIALS.
6. ELECTROCUTION CAN OCCUR IF GENERATOR IS USED IN RAIN, SNOW, OR NEAR WATER, KEEP THIS UNIT DRY AT ALL TIMES.

ENGINE OIL WARNING

You must add oil before first operating the generator. Always check the oil level before each operation. The oil level should always register within the hatched area on the dipstick. The unit is equipped with an oil sensor which will automatically shut off the engine if oil level falls below a safe limit.

LOW OIL WARNING !

IN THE CASE OF AUTO-STOP OR LIGHTING OF OIL PRESSURE ALERT LAMP, DO NOT RUN ENGINE WITHOUT CHECKING OIL LEVEL.



CHECK ENGINE OIL
EACH TIME FILLED
SAE10W30 (CCCLASS)

HOT SURFACE WARNING

Do not touch the muffler or aluminium cylinder of the engine. They are very HOT and will cause severe burns. Don't put any flammable or combustible materials in the direct path of the exhaust.



HOT MUFFLER

WARNING ICONS



English

ELECTRICAL

GENERATOR CAPACITY

Make sure the generator can supply enough continuous (running) and surge (starting) watts for the items you will power at the same time. Follow these simple steps.

1. Select the items you will power at the same time.
2. Total the continuous (running) watts of these items. This is the amount of power the generator must produce to keep the items running. See the wattage reference chart at right.
3. Estimate how many surge (starting) watts you will need. Surge wattage is the short burst of power needed to start electric motor-driven tools or appliances such as a circular saw or refrigerator. Because not all motors start at the same time, total surge watts can be estimated by adding only the item(s) with the highest additional surge watts to the total rated watts from step 2.

Example:

Tool or Appliance	Continuous (Running) Watts	Surge (Starting) Watts
CD Player	100	0
Space Heater	1800	0
Drill	500	0
Light (75 Watts)	75	75
	2475 Total Running Watts	75 Highest Surge Watts

Total Continuous (Running) Watts 2475
 Plus Highest Additional Surge Watts + 75

Equals Total Generator Output Required 2550

POWER MANAGEMENT

To prolong the life of the generator and attached devices, it is important to take care when adding electrical loads to the generator. There should be nothing connected to the generator outlets before starting its engine. The correct and safe way to manage generator power is to sequentially add loads as follows:

1. With nothing connected to the generator, start the engine as described later in this manual.
2. Plug in and turn on the first load, preferably the largest load (highest wattage) you have.
3. Permit the generator output to stabilise (engine runs smoothly and attached device operates properly).
4. Plug in and turn on the next load.
5. Again, permit the generator to stabilise.

6. Repeat steps 4 and 5 for each additional load.

Never add more loads than the generator capacity. Take special care to consider surge loads in generator capacity as previously described.

CAUTION:

Do not overload the generator's capacity. Exceeding the generator's wattage/amperage capacity can damage the generator and/or electrical devices connected to it.

Tool or Appliance	Typical Continuous* (Running) Watts	Typical Surge (Starting) Watts
Essentials		
Light Bulb – 75 Watt	75	75
Refrigerator/Freezer	700	2200
Sump Pump – 1/2 HP	1050	2200
Water Well Pump – 1/3 HP	1000	1500
Electric Water Heater	4000	4000
Heating/Cooling		
Furnace Fan – 1/2 HP	800	2350
Window AC – 10,000 BTU	1200	1800
Space Heater	1800	1800
Kitchen		
Microwave Oven – 1000 Watt	1000	1000
Coffee Maker	1000	1000
Electric Stove – Single Element	2100	2100
Toaster Oven	1200	1200
Family Room		
VCR	100	100
CD/DVD Player	100	100
Stereo Receiver	450	450
Colour Television – 27 in.	500	500
Other		
Security System	500	500
Curling Iron	1500	1500
Garage Door Opener – 1/2 HP	875	2350
Hair Dryer	1250	1250
DIY/Job Site		
Quartz Halogen Work Light	1000	1000
Airless Sprayer – 1/3 HP	600	1200
Reciprocating Saw	960	1400
Electric Drill – 1/2 HP	600	900
Circular Saw – 7-1/4 in.	1400	2300
Mitre Saw – 10 in.	1800	2900
Planner/Joiner – 6 in.	1800	1800
Table Saw/Radial Arm Saw – 10 in.	2000	3000
Air Compressor – 1 HP	1600	4500

*Wattages listed are approximate. Check tool or appliance for actual wattage.

English

FEATURES

Model	RGN3800A
AC Output	
AC Frequency (Hz)	50
AC Output voltage (V)	230
Rated AC Output (W)	3,200
Rated Current (A)	13.9
Circuit Breaker (A)	14
Power Factor	1.0
Generator Mode	Floating Neutral
DC Output	
Volts	12
Amps	8.3
Engine	
Engine Number	UP177
Engine Type	4-Stroke; air-cooled OHV; Gasoline
Bore x Stroke (mm)	77 x 58
Displacement (cc)	270
Starting System	recoil
Fuel Type	Unleaded fuel
Lubrication oil	SAE 10W-30
Engine Oil Volume (l)	1.0L
Fuel Tank Capacity (l)	25
Max. Output (hp)	9.0
Max Output (rpm)	3,000
Run Time (Full Load)	10 (hrs)
Run Time (Half Load)	18 (hrs)
Approvals	
CE	Yes
SAA	Yes
Euro Emission	Yes
Noise Level LpA dB (A)	72
Noise Level LwA dB (A)	96
Uncertainty dB (A)	2

English

FEATURES

KNOW YOUR GENERATOR

See Figure 3.

The safe use of this product requires an understanding of the information on the product and in this operator's manual as well as a knowledge of the project you are attempting. Before use of this product, familiarise yourself with all operating features and safety rules.

AC CIRCUIT BREAKER

The circuit breaker is provided to protect the generator against electrical overload and can be used to turn the generator's electrical power on or off.

AIR FILTER

The air filter helps to limit the amount of dirt and dust drawn into the unit during operation.

CHOKE LEVER

The choke lever is used when starting the engine.

ENGINE SWITCH

The engine switch is used in combination with the recoil starter grip to start the generator. It is also used to turn the generator off.

FUEL LEVEL GAUGE

Consult the fuel level gauge to determine the amount of fuel remaining in the generator.

FUEL TANK

25 litres

FUEL VALVE

The flow of fuel through the generator is controlled by the position of the fuel valve.

COMMON (GROUND) TERMINAL

The ground terminal is used to assist in properly grounding the generator to help protect against electrical shock. Consult with a local electrician for grounding requirements in your area.

OIL DRAINAGE PLUG

See Figure 10

When changing the engine oil, the oil drainage plug is loosened to allow old oil to be drained.

OIL CAP/DIPSTICK

Remove the oil fill cap to check and add oil to the generator when necessary.

RECEPTACLES

Your generator has the following single phase, 50 Hz outlets: two 230 Volt AC, 15Amp receptacles. These can be used for operating appropriate appliances, electrical lighting, tools, and motor loads.

RECOIL STARTER GRIP

The recoil starter grip is used (along with the engine switch) to start the generator's engine.

DC TERMINALS

The DC terminals may ONLY be used for charging 12 volt automotive type batteries.

The terminals are coloured red to identify the positive (+) terminal and black to identify the negative (-) terminal. The battery must be connected to the generator DC terminals with the proper polarity (battery positive to generator red terminal and battery negative to the generator black terminal).

DC CIRCUIT PROTECTOR

The DC circuit protector automatically shuts off the DC battery charging circuit when the DC charging circuit is overloaded, when there is a problem with the battery, or when the connections between the battery and the generator are improper.

BREATHING VALVE

Regulate the internal pressure of the fuel tank and keep the fuel running on lines.

ELECTROMAGNET VALVE

This closes the main jet in the carburetor when the On/Off switch is set to Off. This shuts off fuel supply once the engine starts running down, minimizing the risk of backfire occurring. These are also referred to as anti-backfire solenoids.

ASSEMBLY

UNPACKING

This product has been shipped completely assembled.

- Remove one end of the box and carefully slide out the generator and any accessories.

NOTE: The generator is heavy. If you must lift the unit out of the box, get another person to help you and lift with your legs, not your back.

- Inspect the unit carefully to make sure no damage occurred during shipping.
- Do not discard the packing material until you have carefully inspected and satisfactorily operated the product.
- If any parts are damaged or missing, please contact your nearest authorised service centre for assistance.

English

PACKING LIST

Generator	Spark Plug Wrench
Oil Bottle / Oil Funnel	Handle and Wheels
Operator's Manual	



WARNING:

If any parts are damaged or missing do not operate this product until the parts are replaced. Failure to heed this warning could result in serious personal injury.



WARNING:

Do not attempt to modify this tool or create accessories not recommended for use with this tool. Any such alteration or modification is misuse and could result in a hazardous condition leading to possible serious personal injury.

OPERATION



DANGER:

Carbon Monoxide. Using a generator indoors WILL KILL YOU IN MINUTES.

Generator exhaust fumes contains high levels of carbon monoxide (CO), a poisonous gas you cannot see or smell. If you can smell the generator exhaust fumes, you are breathing CO. But even if you cannot smell the exhaust fumes, you could be breathing CO.

- Never use a generator inside homes, garages, crawlspaces, or other partly enclosed areas. Deadly levels of carbon monoxide can build up in these areas. Using a fan or opening windows and doors does NOT supply enough fresh air.
- ONLY use a generator outdoors and far away from open windows, doors, and vents. These openings can pull in generator exhaust fumes.

Even when you use a generator correctly, CO may leak into the home. ALWAYS use a battery-powered or battery-backup CO alarm in the home.

If you start to feel sick, dizzy, or weak after the generator has been running, move to fresh air immediately. See a doctor. You could have carbon monoxide poisoning.



WARNING:

Do not allow familiarity with tools to make you careless. Remember that a careless fraction of a second is sufficient to inflict serious injury.



WARNING:

Do not use any attachments or accessories not

recommended by the manufacturer of this product. The use of attachments or accessories not recommended can result in serious personal injury.

APPLICATIONS

This generator is designed to supply electrical power for operating compatible electrical lighting, appliances, tools, and motor loads.

BEFORE OPERATING THE UNIT

Position the generator on a flat surface before checking fluid levels or adding fluid.



CAUTION:

Attempting to start the engine before it has been properly filled with oil will result in equipment failure.

CHECKING/ADDING OIL

See Figure 4.

Engine oil has a major influence on engine performance and service life. For general, all-temperature use, SAE 10W-30 is recommended. Always use a 4-stroke motor oil that meets or exceeds the requirements for API service classification SJ.

NOTE: Non-detergent or 2-stroke engine oils will damage the engine and should not be used.

- Unscrew the oil cap/dipstick and remove.
- Wipe dipstick clean and re-seat in hole; do not re-thread.
- Remove dipstick again and check oil level. Oil level should fall within the level indicator area on the dipstick.
- If level is low, add engine oil until the fluid level rises to the upper portion of the level indicator area on the dipstick.
- Replace and secure the oil cap/dipstick.

CHECKING/ADDING FUEL

See Figure 5.

- Check the fuel level gauge. If fuel is needed, continue with the next step.
- Remove the fuel cap.
- Fill the fuel tank to 25mm below the top of the fuel neck.
- Replace and secure the fuel cap.

NOTE: Always use unleaded gasoline with a pump octane rating of 86 or higher. Never use old, stale, or contaminated unleaded fuel, and do not use an oil/fuel mixture. Do not allow dirt or water into the fuel tank.

USING FUEL STABILISER

Fuel gets old, oxidizes, and breaks down over time. Adding a fuel stabiliser extends the usable life of fuel and helps prevent deposits from forming that can clog the fuel system. Follow fuel stabiliser manufacturer's directions for correct ratio of stabiliser to fuel.

- Add stabiliser to fuel tank, then fill with unleaded fuel following previous instructions.

NOTE: Fuel stabiliser and unleaded fuel can be mixed prior to filling the tank by using a fuel can or other approved fuel container and shaking gently to combine.

- Replace and secure the fuel tank cap.
- Start and run the engine for at least 5 minutes to allow stabiliser to treat the entire fuel system.

OXYGENATED FUELS

DO NOT USE E85 FUEL. IT WILL VOID YOUR WARRANTY.

NOTE: Some conventional petrols are blended with alcohol or an ether compound. This type of petrol is collectively referred to as oxygenated fuel; in Australia known as Ethanol. The use of ethanol fuel, or fuels containing ethanol is not recommended for this product.



CAUTION:

On a level surface with the engine off, check the oil level before each use of the generator.

AC OPERATION

- Unplug all loads from the generator.
- Switch the AC circuit breakers to the OFF (O) position.
- Start the engine .(refer to "STARTING THE ENGINE" section)
- Switch the AC circuit breakers to the ON (I) position.
- Plug in the appliance.

DC OPERATION

The DC terminals may ONLY be used for charging 12 volt automotive type batteries.



CAUTION:

The battery gives off explosive gases; keep sparks, flames and cigarettes away. Provide adequate ventilation when charging or using batteries.



CAUTION:

Battery posts, terminals and related accessories contain lead and lead compounds. Wash hands after handling.

Connecting the battery cables:

- Before connecting the battery charging cables to a battery that is installed in a vehicle, disconnect the vehicle ground battery cable from the battery negative (-) terminal.
- Connect the generator positive (+) battery cable to the battery positive (+) terminal.
- Connect the generator negative (-) battery cable to the battery negative (-) terminal.
- Connect the other ends of the generator battery cables to the generator.
- Start the engine. (refer to "STARTING THE ENGINE" section)

NOTE: Do not start the vehicle while the battery charging cable is connected and the generator is running. The vehicle or the generator may be damaged.

An overloaded DC circuit, excessive current draw by the battery, or a wiring problem will trip the DC circuit protector (PUSH button extends out). If this happens, wait a few minutes before pushing in the circuit protector to resume operation. If the DC circuit protector continues to go OFF, discontinue charging and see your nearest authorised service centre.

Disconnecting the battery cables:

- Turn the generator off.
- Disconnect the generator battery cable from the generator.
- Disconnect the other end of the negative (-) generator cable from the battery negative (-) terminal.
- Disconnect the positive (+) generator cable from the battery positive (+) terminal.
- Reconnect the vehicle ground battery cable to the battery negative (-) terminal.

STARTING THE ENGINE

See Figures 6 - 8.

NOTE: If location of generator is not level, the unit may not start or may shut down during operation.

- Turn the fuel valve to the ON position.
 - Move the choke lever to the START position.
- NOTE:** If engine is warm, push the choke lever in to the RUN position.
- Put the engine switch in the ON (I) position.
 - Pull the recoil starting grip until the engine runs (a maximum of 6 times).
- NOTE:** Do not allow the grip to snap back after starting; return it gently to its original place.
- Allow the engine to run for 30 seconds, then move the choke lever in to the RUN position.

English

STOPPING THE ENGINE

See Figures 6- 7.

To stop the engine under normal operating conditions:

- Remove any load from the generator.
- Switch the AC circuit breakers to the OFF position.
- Disconnect DC battery charging cables.
- Turn the fuel valve to the OFF position.
- Put the engine switch in the OFF (O) position.
- Turn the key to "OFF" position (Electric start only).

To stop the engine in an emergency situation:

- Put the engine switch in the OFF (O) position.

MAINTENANCE



WARNING:

When servicing, use only identical replacement parts. Use of any other parts may create a hazard or cause product damage.

Only the parts shown on the parts list are intended to be repaired or replaced by the customer. All other parts should be replaced at an authorised service centre.

GENERAL MAINTENANCE

Keep the generator in a clean and dry environment where it is not exposed to dust, dirt, moisture, or corrosive vapours. Do not allow the cooling air slots in the generator to become clogged with foreign material such as leaves, snow, etc.

Do not use a garden hose to clean the generator. Water entering the fuel system or other internal parts of the unit can cause problems that will decrease the life of the generator.

To clean the unit:

- Use a soft bristle brush and/or vacuum cleaner to loosen and remove dirt and debris.
- Clean air vents with low pressure air that does not exceed 25 psi.
- Wipe the exterior surfaces of the generator with a damp cloth.

CHECKING/CLEANING AIR FILTER

See Figure 9.

For proper performance and long life, keep air filter clean.

- Lift the latches located at the top and bottom of the air filter cover. Remove the cover and set aside.
- Remove the filter elements.
- If the filter elements are dirty, clean with warm, soapy water. Rinse and let dry.
- Apply a light coat of engine oil to the elements, then squeeze it out.
- Replace the elements in the air filter unit.
- Replace the air filter cover and close latches to secure.

NOTE: Do not run the generator without the air filter. Rapid engine wear will result.

CHANGING ENGINE OIL

See Figure 10.

- Remove the oil cap/dipstick.
- Place a container underneath the oil drainage plug to collect used oil as it drains.
- Unscrew the oil drainage plug and remove.
- Allow oil to drain completely.
- Reinstall the oil drainage plug and tighten securely.
- Refill with oil following the instructions in the "CHECKING/ADDING OIL" section.
- Reinstall the oil cap/dipstick.

NOTE: Used oil should be disposed of at an approved disposal site. See your local oil retailer for more information.

CLEANING FUEL SEDIMENT CUP

See Figure 11.

The sediment cup prevents dirt and water that may have gotten into the fuel tank from entering the carburetor. If the engine has not been run for a long time, the sediment cup should be cleaned before use.

- Turn the fuel valve to the OFF position.
- Remove the sediment cup using a 10 mm wrench (not provided).
- Remove the O-ring and filter.
- Clean each of the parts in carburetor cleaner or any comparable cleaning product.
- Reinstall the filter, O-ring, and sediment cup. Tighten with wrench to secure.
- Return the fuel valve to ON position and check for leaks.

SPARK PLUG MAINTENANCE

See Figure 12.

The spark plug must be properly gapped and free of deposits to ensure proper engine operation. To check:

- Remove the spark plug cap.
- Clean any dirt from around base of spark plug.
- Remove spark plug using wrench provided.
- Inspect spark plug for damage, and clean with a wire brush before reinstalling. If insulator is cracked or chipped, spark plug should be replaced.

NOTE: If replacing, use the following recommended spark plugs or equivalent: Champion RN11YC or NGK BPR6ES.

- Seat spark plug in position; thread in by hand to prevent cross-threading.
- Tighten with wrench to compress washer. If spark plug is new, use 1/2 turn to compress washer. If reusing old spark plug, use 1/8 to 1/4 turn for proper washer compression.

English

NOTE: An improperly tightened spark plug will become very hot and could damage the engine.

CLEANING THE EXHAUST PORT AND MUFFLER

Depending on the type of fuel used, the type and amount of oil used, and/or your operating conditions, the exhaust port and muffler may become blocked with carbon deposits. If you notice a power loss with your petrol-powered tool, you may need to remove these deposits to restore performance. We highly recommend that only qualified service technicians perform this service.

SPARK ARRESTOR

Product users in some areas must comply with fire prevention regulations. This product is equipped with a spark arrestor in accordance with Australian requirements.

DRAINING FUEL TANK / CARBURETOR

When not using a fuel stabiliser, draining the fuel from the tank and carburetor before storage may help prevent gum deposits in the fuel system.

DRAINING THE FUEL TANK

See Figure 13.

- Turn the engine switch OFF (O).
- Close the fuel valve.
- Remove the fuel line from the barb by squeezing the ends of the retaining clip and sliding the fuel line off.
- Install one end of a drain line over the barb, and place the other end in a fuel container large enough to catch the fuel being drained from the tank.
- Open the fuel valve.
- When the fuel has drained from the tank, close the fuel valve and reinstall fuel line on barb.

DRAINING THE CARBURETOR

See Figure 2.

- Turn the engine switch OFF (O).
- Close the fuel valve.
- Position an approved fuel container under the carburetor drain screw to catch fuel; loosen the screw.
- Allow fuel to drain completely into the container.
- Retighten the drain screw.

NOTE: After draining the fuel tank and carburetor, start the engine and allow it to run until the unit runs out of fuel. Consult hazardous waste management guidelines in your area for the proper way to dispose of fuel.

TRANSPORTING

- Turn engine switch OFF (O).

- Close the fuel valve.
- Make sure engine and exhaust of unit is cool.
- Keep unit level to prevent fuel spillage.
- Do not drop or strike unit or place under heavy objects.

English

MAINTENANCE

STORAGE

When preparing the generator for storage, follow the guidelines below.

STORAGE TIME	PRIOR TO STORING
Less than 1 month	<ul style="list-style-type: none"> ■ No special preparation is required.
1 to 2 months	<ul style="list-style-type: none"> ■ Empty fuel from the fuel tank.
2 months to 1 year	<ul style="list-style-type: none"> ■ Empty fuel from the fuel tank. ■ Drain fuel from the carburetor. ■ Clean the fuel sediment cup.
1 year or more	<ul style="list-style-type: none"> ■ Empty fuel from the fuel tank. ■ Drain fuel from the carburetor. ■ Clean the fuel sediment cup. ■ Remove the spark plug. ■ Put a tablespoon of engine oil into the cylinder through the spark plug hole. Turn the engine slowly with the pull rope to distribute the oil. ■ Reinstall the spark plug. ■ Change the engine oil.

* Use unleaded fuel stabilisers formulated to extend storage life. For recommendations, contact your nearest authorised service center.

MAINTENANCE SCHEDULE

	Before each use	After 1st month or 20 hours of operation	Every 3 months or 50 hours of operation	Every 6 months or 100 hours of operation	Every year or after 300 hours of operation
Check Engine Oil	■				
Change Engine Oil		■		■	
Check Air Filter	■				
Clean Air Filter			■		
Change Air Filter					■
Clean Carburetor Sediment Cup				■	
Check/Adjust Spark Plug				■	
Replace Spark Plug					■
Check/Adjust Idle Speed					■
Check/Adjust Valve Clearance*					■
Clean Fuel Tank and Filter*				■	
Check Fuel Tube					■

* These items should only be carried out by an authorised service center.

NOTE: Maintenance should be performed more frequently when generator is used in dusty areas.

When generator has exceeded the maximum figures specified in the table, maintenance should still be cycled according to the intervals of time or hours stated herein.

English

MAINTENANCE

PROBLEM	POSSIBLE CAUSE	SOLUTION
Engine will not start.	Engine switch is OFF. No fuel. Oil level is low. Fuel valve is OFF. Spark plug faulty, fouled, or improperly gapped. Fuel is not reaching carburetor. Choke is OPEN. Engine stored without treating or draining unleaded fuel, or refueled with bad unleaded fuel.	Turn engine switch to ON. Fill fuel tank. Check engine oil level and fill, if necessary. Turn fuel valve ON. Replace spark plug. Clean fuel sediment cup. Move choke lever out to START. Drain fuel and carburetor. Refuel with fresh unleaded fuel.
Engine lacks power.	Air filter element clogged. Engine stored without treating or draining unleaded fuel, or refueled with bad unleaded fuel.	Check air filter element. Clean or replace as needed. Drain fuel and carburetor. Refuel with fresh unleaded fuel.
AC receptacle does not work.	Circuit breaker is OFF. Item plugged in is defective.	Turn ON the AC circuit breaker. Try a different item.
Generator makes a "spark knock" or "pinging" noise.	An occasional light "knocking" or "pinging" under heavy load is not a cause for concern. However, if the knocking or pinging occurs under normal load at a steady engine speed, the problem may be with the brand of unleaded fuel being used.	Switch to a different brand of unleaded fuel, making sure that the octane rating is 86 or higher. If problem continues, contact your nearest authorized service center.
If problem persists after trying the above solutions, contact your nearest authorized service center for assistance.		
The following symptoms may indicate problems that will affect the emissions level of the unit: <ul style="list-style-type: none"> ■ Hard starting or stalling after starting ■ Rough idle ■ Misfiring or backfiring under load ■ Afterburning (backfiring) ■ Black exhaust smoke or high fuel consumption If you encounter any of these symptoms, have the unit inspected and repaired by the nearest authorized service center.		

WIRING DIAGRAM - RGN3800A

English

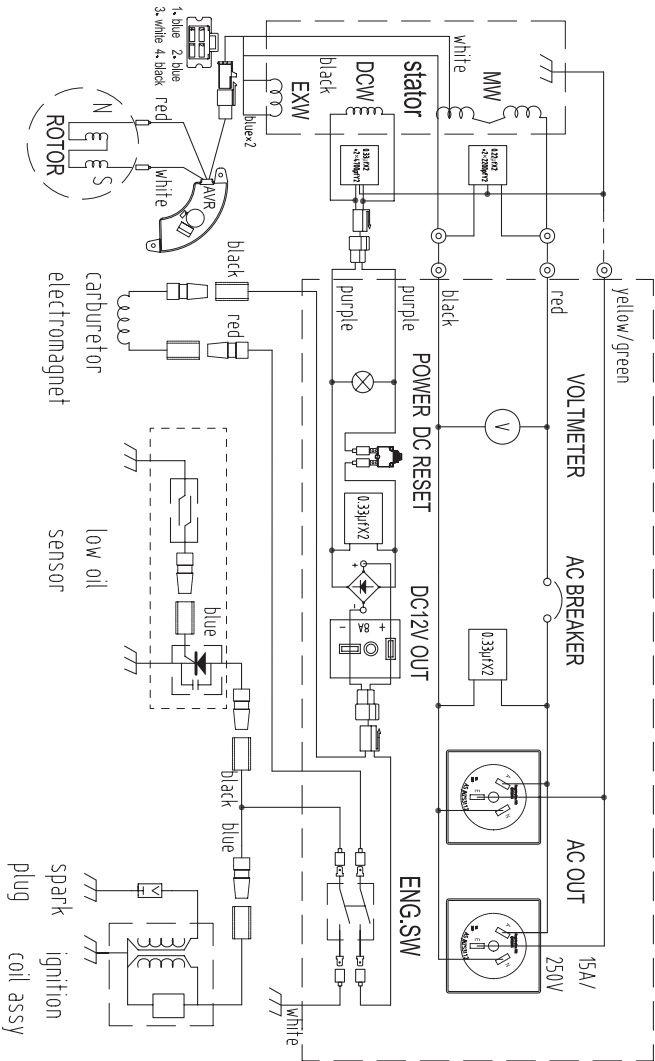



Techtronic Industries (Australia) Pty. Ltd.
Level 1, 660 Doncaster Road
Doncaster, VIC 3108, Australia

Techtronic Industries New Zealand Ltd.
18-26 Amelia Earhart Avenue
Mangere, Auckland 2022, New Zealand

