

## TOPDRY Folding Frame – Fixed Post Kit

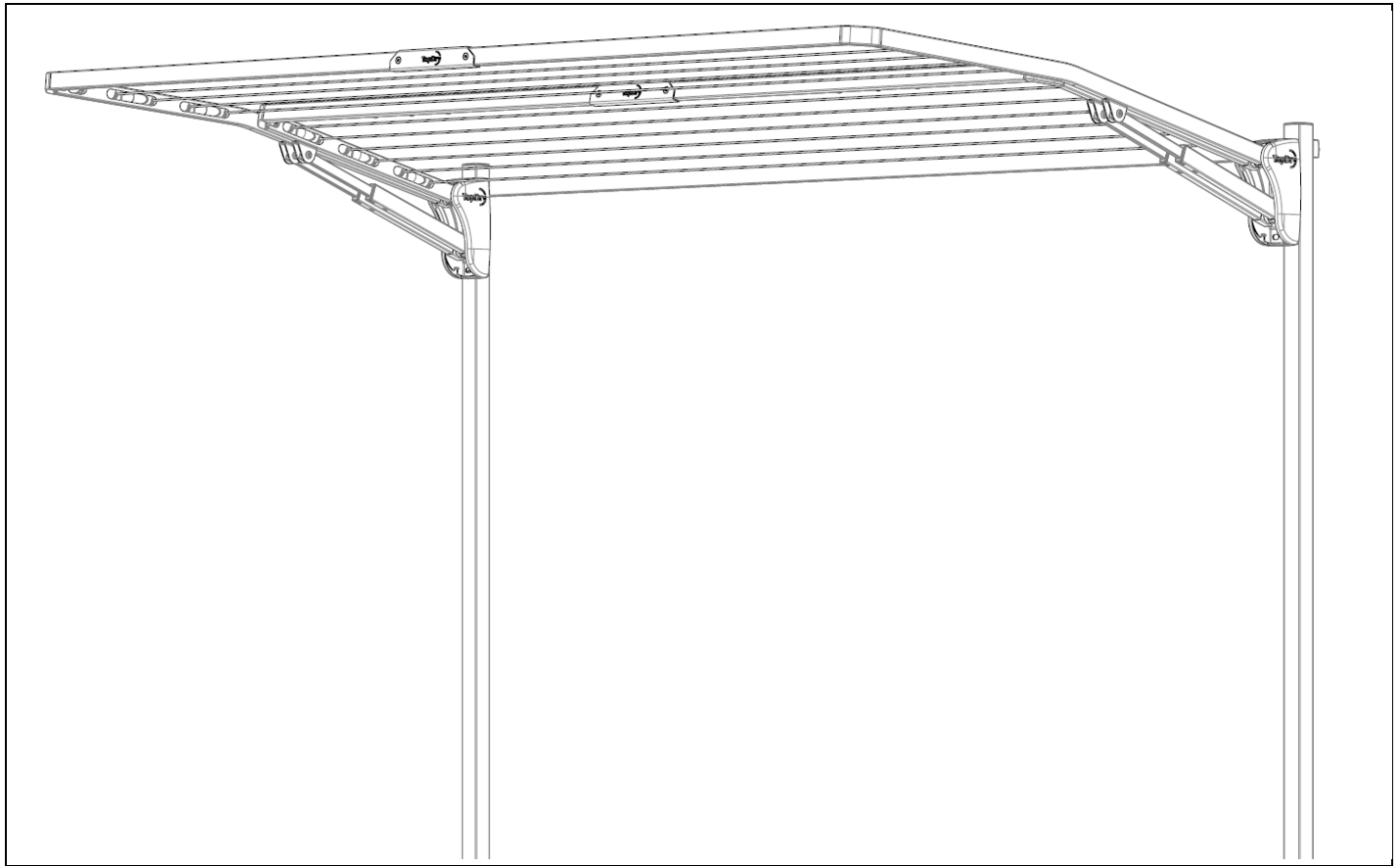

## Safety Tips

Only use your clothesline to hang and dry washing.

Remember the clothesline is not a children's toy

Don't use your clothesline if it or the Post Kit is damaged

Note the following for future reference

Product Name	
Date of purchase:	
Place of purchase:	

## Package Contents

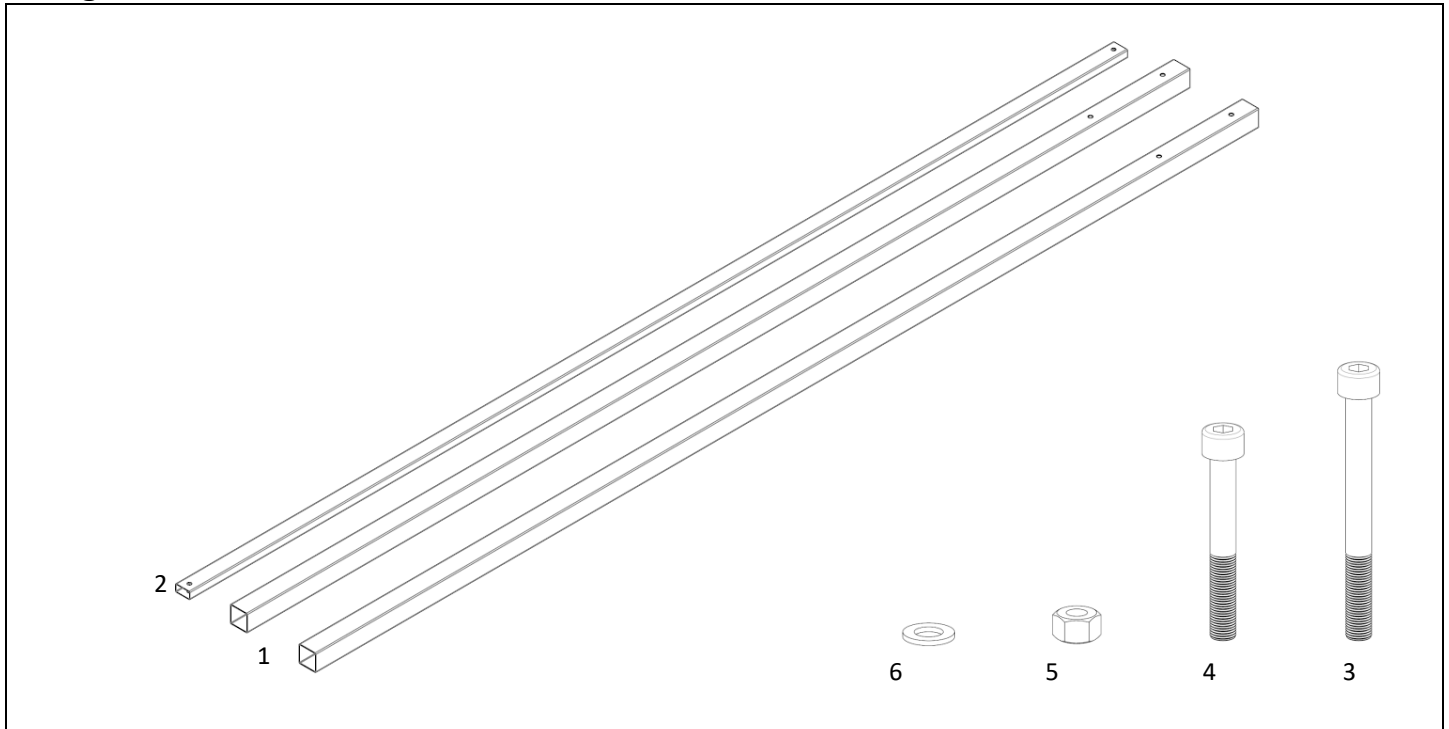

Item	Description	Quantity
1	Fixed Post	2
2	Cross Brace	1
3	M8 x 80mm Socket Head Cap Screw	2

Item	Description	Quantity
4	M8 x 60mm Socket Head Cap Screw	2
5	M8 Nut	4
6	M8 Washer	4

# 1. Select a suitable location

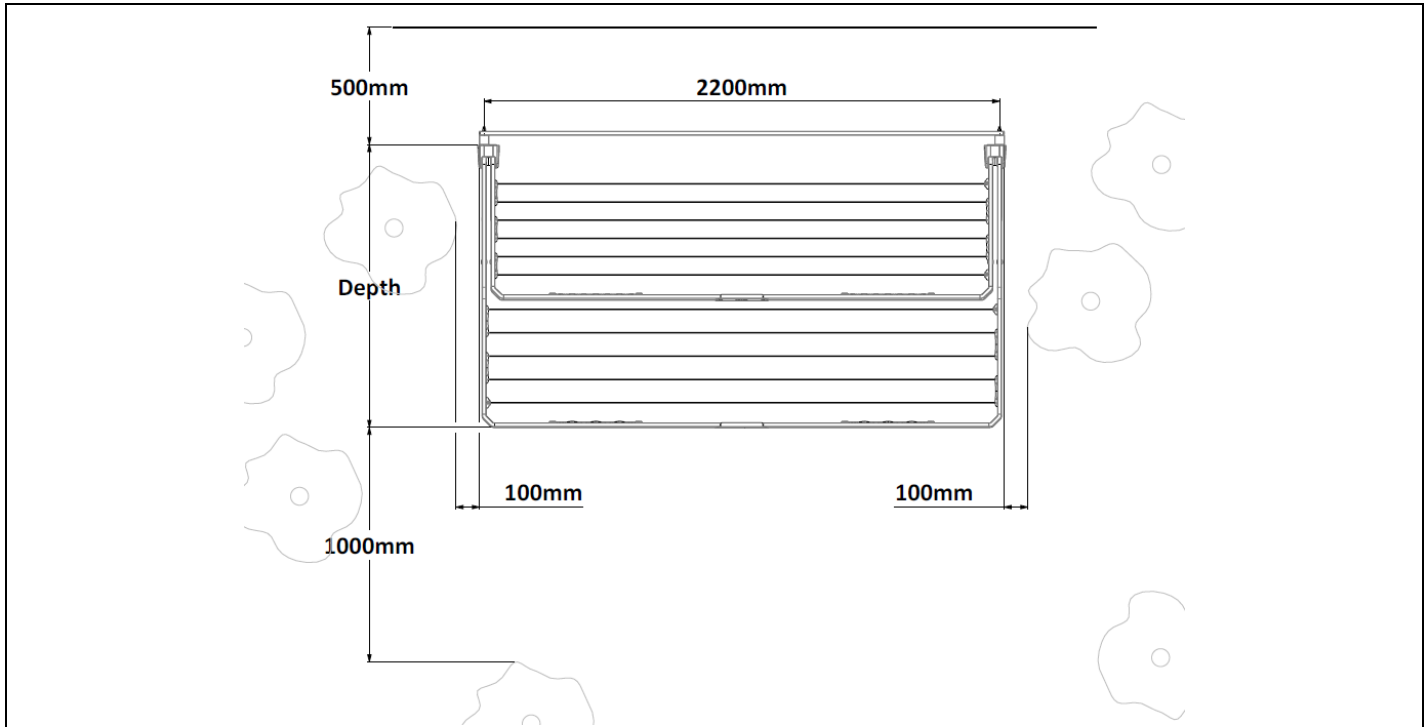

Leave space around the product as shown in the diagram.

Product	Depth
Double Folding Frame	1210 mm
Single Folding Frame	1210mm
Slim Folding Frame	670mm

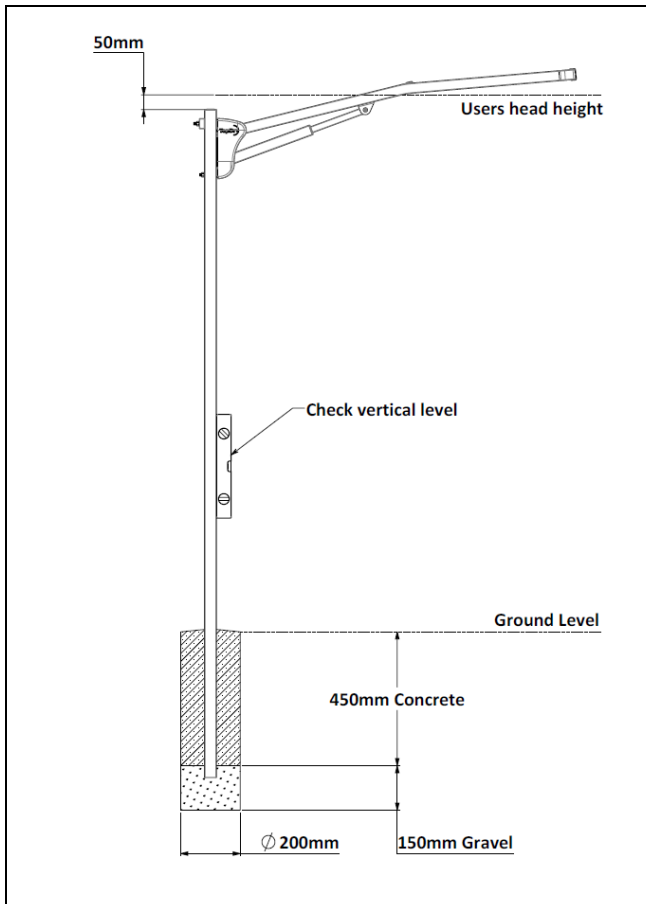

## 2. Install the posts

1. After choosing your installation location, dig two holes 2200mm apart.
2. Make the holes 600mm deep and 200mm diameter.
3. Put 150mm of dry gravel in the hole
4. Put one post in each hole, pushing the posts into the gravel to set the correct height. Make sure the height of both posts are the same.
5. Loosely assemble the cross brace using the M8 x 80 Socket head cap screws, washers and nuts.

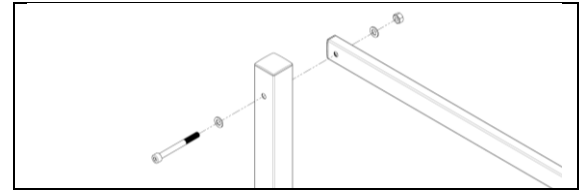

6. Using a spirit level check the posts are vertically level and parallel.
7. Concrete the posts into position using a quick-set concrete. Make sure to slope the top of the concrete away from the post for drainage.
8. Re-check that the posts are level and parallel and allow the concrete to set for at least 24 hours.
9. Using the supplied fasteners and the instructions provided with your folding frame clothesline, assemble your product to the posts.

# Warranty - Terms and Conditions

Any claim under this warranty must be made within ten years of the date of purchase of the product. Please note that the PVC line is only covered for 12 months from date of purchase.

To make a claim under the warranty, take the product (with proof of purchase) to any Bunnings store (see [www.bunnings.com.au](http://www.bunnings.com.au) for store locations).

Sales Force National Pty Ltd (t/a Zenexus) bears reasonable, direct, expenses of claiming under the warranty. You may submit details and proof into any Bunnings store for consideration.

The warranty covers manufacturer defects in materials, workmanship and finish under normal use.

This warranty is provided in addition to other rights and remedies you may have under law: our goods come with guarantees which cannot be excluded under the Australian Consumer Law. You are entitled to replacement or refund for a major failure and to compensation for other reasonably foreseeable loss or damage. You are also entitled to have the goods repaired or replaced if the goods fail to be of acceptable quality and the failure does not amount to a major failure. If the clothesline is repaired or partly replaced under warranty the original warranty will not be extended

The warranty excludes damage resulting from product misuse or product neglect. The warranty covers domestic use only and does not apply to commercial applications.

This warranty is given by Sales Force National Pty Ltd (t/a Zenexus), ABN: 60 110 379 587. Phone: 1300 734 714 (AU), 0800 800 040 (NZ). E-mail: [customerservice@zenexus.com.au](mailto:customerservice@zenexus.com.au), [customerservice@zenexus.co.nz](mailto:customerservice@zenexus.co.nz) . Website: [www.zenexus.com.au](http://www.zenexus.com.au)

## WARRANTY EXCLUSIONS

Fading due to weather exposure or damage to the frame and line through accident misuse or negligence